



# EPB

PLASTERBOARD

# **FIRE RATED**

# SYSTEMS

March 2025

---

[www.epb.co.nz](http://www.epb.co.nz)

## EPB® Plasterboard Fire Rated Systems Manual

These publications are continuously being updated and superseded. **CURRENT VERSION DATED: November 2025**

It is important to check to ensure you have the latest publication. Call Freephone 0800 353 742.

Liability for systems and performances that are not designed and installed in accordance with this publication will not be accepted by Elephant Plasterboard (NZ) Limited.

### Copyright

All the material in this document including text, diagrams, figures, patterns, pictures, tables and cad drawings are protected by copyright.

### Cad Drawings

Pictures and CAD drawings may be downloaded and used in consented plans for generic references only. Elephant Plasterboard (NZ) Limited takes no liability in CAD drawing details shown. It is up to the designer and or builder to provide specific details and or building construction methods in each case. All pictures and CAD details are generic only.

### Elephant Plasterboard (NZ) Limited Trademarks:

EPB® Plasterboard, Elephant Plasterboard®, Elephant Board®,

EPB® Standard, EPB FireSmart®, EPB MultiSmart®, EPB AquaSmart®, EPB CeilingSmart®, EPB BraceSmart®, EPB NoiseSmart®, EPB Smartboard®, Elephant Standard Plasterboard®, SmartRock Plasterboard®, Elephant FireSmart®, Elephant MultiSmart®, Elephant AquaSmart®, Elephant CeilingSmart®, Elephant SpanSmart®, Elephant SuperSmart®, Elephant BraceSmart®, Elephant NoiseSmart®, Elephant UltraSmart®, Elephant Standard-Plus®, Elephant ImpactSmart®

All past and future references to Elephant Plasterboard and EPB® Plasterboard are interchangeable.

### Introducing new 10mm EPB FireSmart & 10mm EPB CeilingSmart®

10mm EPB FireSmart® is a higher density board compared to 10mm EPB® Standard and provides enhance fire performance.

10mm EPB CeilingSmart® is especially developed to span ceiling battens at 600mm centers providing a light weight and cost effective ceiling lining solution compared to using 10mm EPB® Standard Plasterboard at 450mm centres or 13mm EPB® Standard Plasterboard at 600mm centre.

### Elephant Plasterboard (NZ) Limited Product & System Warranty

EPB® Plasterboard wall and ceiling linings are supported by Elephant Plasterboard (NZ) Limited Quality Guarantee. This Warranty covers EPB Plasterboard products and or systems for a minimum of 10 years from the date of the purchase. Elephant Plasterboard (NZ) Limited supplies products which are warranted to be free from defects. Any products found to be defective before or after installation will be replaced and/or repaired, provided installation has been in accordance with EPB® Plasterboard's technical literature.

#### Freephone

0800 353 742

#### Email

info@epb.co.nz

#### Website

www.epb.co.nz

#### Telephone

+64 (09) 818-7706

Elephant Plasterboard (NZ) Limited  
14 Bancroft Crescent, Glendene, Auckland 0602  
P.O. Box 21-436, Waitakere 0650  
New Zealand



# CONTENTS

<b>SYSTEM SELECTOR TABLE</b>	<b>4-21</b>
<b>INTRODUCTION</b>	<b>22-27</b>
Limitations and Conditions of Use	
NZBC Building Code Compliance	
Fire Resistance Ratings (FRR)	
Internal lining Surface Finish Properties	
Fire Rated Walls	
Universal Walls	
EPB QuickBrace System	
Fire Rated Floor/Ceiling Systems	
Universal Ceiling Systems	
Acoustic Sealant	
Load Bearing & Non-Load Bearing Studs	
EPB Plasterboard Substitution options	
<b>NOMENCLATURE</b>	<b>28</b>
EPB Specification Reference - Wall Systems	
EPB Specification Reference - Floor/Ceiling Systems	
<b>FIRE SYSTEMS</b>	<b>29-119</b>
Timber Framed Walls	
Steel Framed Walls	
Double Steel Frame with FireSmart Central Liner	
Universal Walls - Timber or Steel Frame	
Smoke Separation Walls	
Floor/Ceiling Systems	
Composite Joist Floor/Ceiling	
Steel Joist Floor/Ceiling	
Battened Floor/Ceiling Systems	
Direct Fix Clip Floor/Ceiling	
Suspended Grid Floor/Ceiling	
Universal Ceiling - Timber or Steel Frame	
Single Timber Frame Wall with Simultaneous Fire Exposure on Both Sides	
EPB Smoke Separation - Timber or Steel	
EPB Shaft Panel	
Shaft Wall	
Steel Column & Beam - Timber Strapped	
Steel Column & Beam - Steel Clip & Channel	
<b>CONSTRUCTION DETAILS</b>	<b>120-151</b>
Penetrations Two way FRR Systems	
T Junctions & Corner Junctions Two way FRR Systems	
Head Details with Negligible Deflection	
Deflection Head Details	
Wall & Floor/Ceiling Junctions	
Composite Floor Deflection Head Details	
Rigid Junctions	
Control Joints	
Ceiling Wall Junction Details	
Shaft Wall	
Boundary Wall Details	
<b>PRODUCT RANGE</b>	<b>152</b>



## Fire Rated Walls

System Number	Lining Suffix	FRR	Load Bearing Ability	Noise Control		Lining Requirements	Page
				STC	Rw		
<b>Timber Frame Walls - Two Way FRR</b>							
E2TL30	-S20	30/30/30	LB	37	36	1 x 10mm EPB® Standard each side	29
	-F20	30/30/30	LB	37	36	1 x 10mm EPB FireSmart® each side	29
	-S26	30/30/30	LB	37	36	1 x 13mm EPB® Standard each side	29
E4TL45	-S40	45/45/45	LB	42	41	2 x 10mm EPB® Standard each side	30
E4T60	-S40	-/60/60	NLB	42	41	2 x 10mm EPB® Standard each side	31
E2TL60	-F26	60/60/60	LB	38	37	1 x 13mm EPB FireSmart® each side	32
E4TL60	-F40	60/60/60	LB	42	41	2 x 10mm EPB FireSmart® each side	33
	-S46	60/60/60	LB	42	41	1 x 10mm EPB® Standard and 1 x 13mm EPB® Standard each side	33
	-MS40	60/60/60	LB	42	41	1 x 10mm EPB® Standard and 1 x 10mm EPB MultiSmart each side	33
	-S52	60/60/60	LB	43	42	2 x 13mm EPB® Standard each side	33
E2TL75	-F32	75/75/75	LB	38	37	1 x 16mm EPB FireSmart® each side	34
E4T90	-FS52	-/90/90	NLB	43	42	1 x 13mm EPB FireSmart® and 1 x 13mm EPB® Standard each side	35
	-FM46	-/90/90	NLB	43	42	1 x 13mm EPB FireSmart® and 1 x 10mm EPB MultiSmart® each side	35
E4TL90	-F52	90/90/90	LB	45	44	2 x 13mm EPB FireSmart® each side	36
E4T105	-F52	-/105/105	NLB	44	43	2 x 13mm EPB FireSmart® each side	37
E4T120	-F58	-/120/120	NLB	46	45	1 x 16mm EPB FireSmart® and 1 x 13mm EPB FireSmart® each side	38
E6TL120	-F78	120/120/120	LB	44	43	3 x 13mm EPB FireSmart® each side	39
EBV1TL30	-F10	30/30/30	LB	46	45	1 x 10mm EPB FireSmart® one side Brick Veneer other side	40
	-S13	30/30/30	LB	46	45	1 x 13mm EPB® Standard one side Brick Veneer other side	40
EBV1TL60	-F13	60/60/60	LB	46	45	1 x 13mm EPB FireSmart® one side Brick Veneer other side	41
EGW1TL30	-F10	30/30/30	LB	37	36	1 x 10mm EPB FireSmart® on internal side 1 x 10mm GIB Weatherline® to external side	42
EGW1TL60	-F13	60/60/60	LB	38	37	1 x 13mm EPB FireSmart® on internal side 1 x 13mm GIB Weatherline® to external side	43
<b>Steel Frame Walls - Two Way FRR</b>							
E2SL15	-S26	15/15/15	LB	35	34	1 x 13mm EPB® Standard each side	45
E2S30	-S26	-/30/30	NLB	35	34	1 x 13mm EPB® Standard each side	46
	-M20	-/30/30	NLB	36	35	1 x 10mm EPB MultiSmart® each side	46
E2SL30	-M26	30/30/30	LB	37	36	1 x 13mm EPB MultiSmart® each side	47
	-F32	30/30/30	LB	37	36	1 x 16mm EPB FireSmart® each side	47
E4SL30	-F40	30/30/30	LB	43	42	2 x 10mm EPB FireSmart® each side	48



## Fire Rated Walls

System Number	Lining Suffix	FRR	Load Bearing Ability	Noise Control		Lining Requirements	Page
				STC	Rw		
E4SL30	-S52	30/30/30	LB	43	42	2 x 13mm EPB® Standard each side	48
E2S60	-F26	-/60/60	NLB	37	36	1 x 13mm EPB FireSmart® each side (requires wall insulation)	49
E4S60	-S52	-/60/60	NLB	45	44	2 x 13mm EPB® Standard each side	50
	-M40	-/60/60	NLB	45	44	2 x 10mm EPB MultiSmart® each side	50
E4SL60	-F52	60/60/60	LB	46	45	2 x 13mm EPB FireSmart® each side	51
E2S75	-F32	-/75/75	NLB	38	37	1 x 16mm EPB FireSmart® each side	52
E4S90	-M46	-/90/90	NLB	45	44	1 x 10mm EPB MultiSmart® and 1 x 13mm EPB MultiSmart® each side	53
E4SL90	-F64	90/90/90	LB	47	46	2 x 16mm EPB FireSmart® each side	54
E4S120	-F52	-/120/120	NLB	45	44	2 x 13mm EPB FireSmart® each side	56
E4S120	-F58	-/120/120	NLB	46	45	1 x 16mm EPB FireSmart® and 1 x 13mm FireSmart® each side	56
<b>Double Steel Frame Wall with FireSmart Central Liner - Two Way FRR</b>							
E2CSD60	-F26	-/60/60	NLB	44	43	1 x 13mm EPB FireSmart® each side (requires wall insulation)	58

## Fire Rated Universal Walls

System Number	Lining Suffix	FRR	Load Bearing Ability	Noise Control		Lining Requirements	Page
				STC	Rw		
<b>Universal Timber or Steel Frame Wall - One Way FRR</b>							
E1UW15	-S13	15/15/15	LB	-	-	1 x 13mm EPB® Standard one side	61
E1UW30	-F16a	30/30/30	LB	-	-	1 x 16mm EPB FireSmart® one side	62
E2UW30	-F20	30/30/30	LB	-	-	2 x 10mm EPB FireSmart® one side	63
E2UW45	-F26	45/45/45	LB	-	-	2 x 13mm EPB FireSmart® one side	64
E2UW60	-F26a	60/60/60	LB	-	-	2 x 13mm EPB FireSmart® one side	65
	-F29	60/60/60	LB	-	-	1 x 16mm EPB FireSmart® and 1 x 13mm EPB FireSmart® one side	65
E3UW90	-F39a	90/90/90	LB	-	-	3 x 13mm EPB FireSmart® one side	66
	-F42	90/90/90	LB	-	-	1 x 16mm EPB FireSmart® and 2 x 13mm EPB FireSmart® one side	66
E3UW120	-F45a	120/120/120	LB	-	-	1 x 13mm EPB FireSmart® and 2 x 16mm EPB FireSmart® one side	67

## Fire Rated Walls with simultaneous fire exposure on both sides

System Number	Lining Suffix	FRR	Load Bearing Ability	Noise Control		Lining Requirements	Page
				STC	Rw		
<b>Single Timber Frame Wall with Simultaneous Fire Exposure on Both sides - Two Way FRR</b>							
E2TL30S	-F26	30/-/-	LB	38	37	1 x 13mm EPB FireSmart® each side	68
E4TL60S	-F52	60/-/-	LB	46	45	2 x 13mm EPB FireSmart® each side	69



## Smoke Separation Walls

System Number	Lining Suffix	FRR	Load Bearing Ability	Noise Control		Lining Requirements	Page
				STC	Rw		
<b>Smoke Separation - Timber or Steel Frame Wall - Two Way FRR</b>							
E2sm10	-	10/10/10	LB	-	-	1 x Minimum 10mm EPB® Plasterboard each side	71

## Fire Rated Floor/Ceilings

System Number	Lining Suffix	FRR	Load Bearing Ability	Noise Control			Lining Requirements	Page
				STC	Rw	IIC		
<b>Floor/Ceiling</b>								
E1FC15	-S13	15/15/15	LB	38	37	31	1 x 13mm EPB® Standard	73
E1FC30	-F13	30/30/30	LB	39	39	32	1 x 13mm EPB FireSmart®	74
E2FC30	-S26	30/30/30	LB	39	38	32	2 x 13mm EPB® Standard	75
E1FC45	-F13	45/45/45	LB	39	39	32	1 x 13mm EPB FireSmart®	76
E1FC60	-F16	60/60/60	LB	39	38	32	1 x 16mm EPB FireSmart®	78
E2FC60	-FS26	60/60/60	LB	40	39	33	1 x 13mm EPB FireSmart® and 1 x 13mm EPB® Standard	80
	-F26	60/60/60	LB	41	40	34	2 x 13mm EPB FireSmart®	80
E2FC90	-F29	90/90/90	LB	41	40	34	1 x 16mm EPB FireSmart® and 1 x 13mm EPB FireSmart®	81
E3FC120	-F45	120/120/120	LB	43	42	35	1 x 13mm EPB FireSmart® and 2 x 16mm EPB FireSmart®	82
<b>Composite Joist Floor/Ceiling</b>								
E1CJ30	-F13	30/30/30	LB	39	38	32	1 x 13mm EPB FireSmart®	83
E2CJ30	-S26	30/30/30	LB	39	38	32	2 x 13mm EPB® Standard	84
E1CJ45	-F13	45/45/45	LB	39	38	32	1 x 13mm EPB FireSmart®	85
E1CJ60	-F16	60/60/60	LB	39	38	32	1 x 16mm EPB FireSmart®	86
E2CJ60	-FS26	60/60/60	LB	40	39	33	1 x 13mm EPB FireSmart® and 1 x 13mm EPB® Standard	87
<b>Steel Joist Floor/Ceiling</b>								
E1SJ30	-F13	30/30/30	LB	35	34	31	1 x 13mm EPB FireSmart®	88
E2SJ60	-F26	60/60/60	LB	39	38	32	2 x 13mm EPB FireSmart®	89
<b>Battened Floor/Ceiling</b>								
E1BC30	-F13	30/30/30	LB	35	34	31	1 x 13mm EPB FireSmart®	90
E1BC60	-F16	60/60/60	LB	39	38	32	1 x 16mm EPB FireSmart®	92
<b>Direct Fix Clip Floor/Ceiling</b>								
E1DF45	-F13	45/45/45	LB	49	48	42	1 x 13mm EPB FireSmart®	94
E1DF60	-F16	60/60/60	LB	49	48	43	1 x 16mm EPB FireSmart®	95



## Fire Rated Floor/Ceilings

System Number	Lining Suffix	FRR	Load Bearing Ability	Noise Control			Lining Requirements	Page
				STC	Rw	IIC		
E2DF60	-FS26	60/60/60	LB	49	48	43	1 x 13mm EPB FireSmart® and 1 x 13mm EPB® Standard	96
	-F26	60/60/60	LB	52	51	43	2 x 13mm EPB FireSmart®	96
E2DF90	-F32	90/90/90	NLB	54	53	43	2 x 16mm EPB FireSmart®	97

### Suspended Grid Floor/Ceiling

E2SC30	-S26	30/30/30	LB	50	49	42	2 x 13mm EPB® Standard	98
E1SC45	-F13	45/45/45	LB	48	47	42	1 x 13mm EPB FireSmart®	99
E1SC60	-F16	60/60/60	LB	48	47	43	1 x 16mm EPB FireSmart®	100
E1XC60	-F16	60/60/60	LB	48	47	43	1 x 16mm EPB FireSmart®	101
E2SC60	-FS26	60/60/60	LB	48	47	42	1 x 13mm EPB FireSmart® and 1 x 13mm EPB® Standard	102
	-F26	60/60/60	LB	51	50	42	2 x 13mm EPB FireSmart®	102
E2SC90	-F32	90/90/90	LB	53	52	43	2 x 16mm EPB FireSmart®	103
E2XC90	-F29	90/90/90	LB	48	47	43	1 x 16mm EPB FireSmart® and 1 x 13mm EPB FireSmart®	104

## Fire Rated Universal Ceilings

System Number	Lining Suffix	FRR	Load Bearing Ability	Noise Control			Lining Requirements	Page
				STC	Rw	IIC		

### Universal Ceiling - Timber or Steel Frame

E1UC15	-F13	15/15/15	LB	-	-	-	1 x 13mm EPB FireSmart®	106
E1UC30	-F16a	30/30/30	LB	-	-	-	1 x 16mm EPB FireSmart®	107
E2UC60	-F26a	60/60/60	LB	-	-	-	2 x 13mm EPB FireSmart®	108
	-F29	60/60/60	LB	-	-	-	1 x 16mm EPB FireSmart® and 1 x 13mm EPB FireSmart®	108
E3UC90	-F39a	90/90/90	LB	-	-	-	3 x 13mm EPB FireSmart®	109
	-F42	90/90/90	LB	-	-	-	1 x 16mm EPB FireSmart® and 2 x 13mm EPB FireSmart®	109



## Fire Rated Speciality Systems

System Number	Lining Suffix	FRR	Load Bearing Ability	Noise Control				Lining Requirements	Page
				STC					
				64mm Stud		102mm Stud			
				No Fill	Fill	No Fill	Fill		
<b>Shaft Wall - Fire Rated from Shaft Side only</b>									
E1SWS60	-F13	-/60/60	NLB	39	45	42	46	1 x 13mm EPB FireSmart®	114
E2SWS90	-F26	-/90/90	NLB	43	49	46	50	2 x 13mm EPB FireSmart®	114
E2SWS120	-F29	-/120/120	NLB	44	50	46	51	1 x 16mm EPB FireSmart® and 1 x 13mm EPB FireSmart®	114
<b>Shaft Wall - Fire Rated from Either Side</b>									
E1SWE30	-F13	-/30/30	NLB	39	45	42	46	1 x 13mm EPB FireSmart®	114
E2SWE60	-F26	-/60/60	NLB	43	49	46	50	2 x 13mm EPB FireSmart®	114
E2SWE90	-F29	-/90/90	NLB	44	50	46	51	1 x 16mm EPB FireSmart® and 1 x 13mm EPB FireSmart®	114
E3SWE120	-F42	-/120/120	NLB	46	51	48	52	1 x 16mm EPB FireSmart® and 2 x 13mm EPB FireSmart®	114
<b>EPB Shaft Panel</b>									
EPB Shaft Panel									112

## Fire Rated Columns & Beams

System Number	Lining Suffix	FRR	Load Bearing Ability	Noise Control		Lining Requirements	Page
				STC	Rw		
<b>Steel Column &amp; Beam - Timber Strapped</b>							
E1CBT15	-S13	15/-/-	LB	-	-	1 x 13mm EPB® Standard	116
E1CBT30	-F16	30/-/-	LB	-	-	1 x 16mm EPB FireSmart®	116
E2CBT30	-F20	30/-/-	LB	-	-	2 x 10mm EPB FireSmart®	116
E2CBT60	-F26	60/-/-	LB	-	-	2 x 13mm EPB FireSmart®	116
E2CBT90	-F32	90/-/-	LB	-	-	2 x 16mm EPB FireSmart®	116
E3CBT120	-F45	120/-/-	LB	-	-	1 x 13mm EPB FireSmart® and 2 x 16mm EPB FireSmart®	116
<b>Steel Column &amp; Beam - Steel Clip and Channel</b>							
E1CBS15	-S13	15/-/-	LB	-	-	1 x 13mm EPB® Standard	118
E1CBS30	-F16	30/-/-	LB	-	-	1 x 16mm EPB FireSmart®	118
E2CBS30	-F20	30/-/-	LB	-	-	2 x 10mm EPB FireSmart®	118
E2CBS60	-F26	60/-/-	LB	-	-	2 x 13mm EPB FireSmart®	118
E2CBS90	-F32	90/-/-	LB	-	-	2 x 16mm EPB FireSmart®	118
E3CBS120	-F45	120/-/-	LB	-	-	1 x 13mm EPB FireSmart® and 2 x 16mm EPB FireSmart®	118



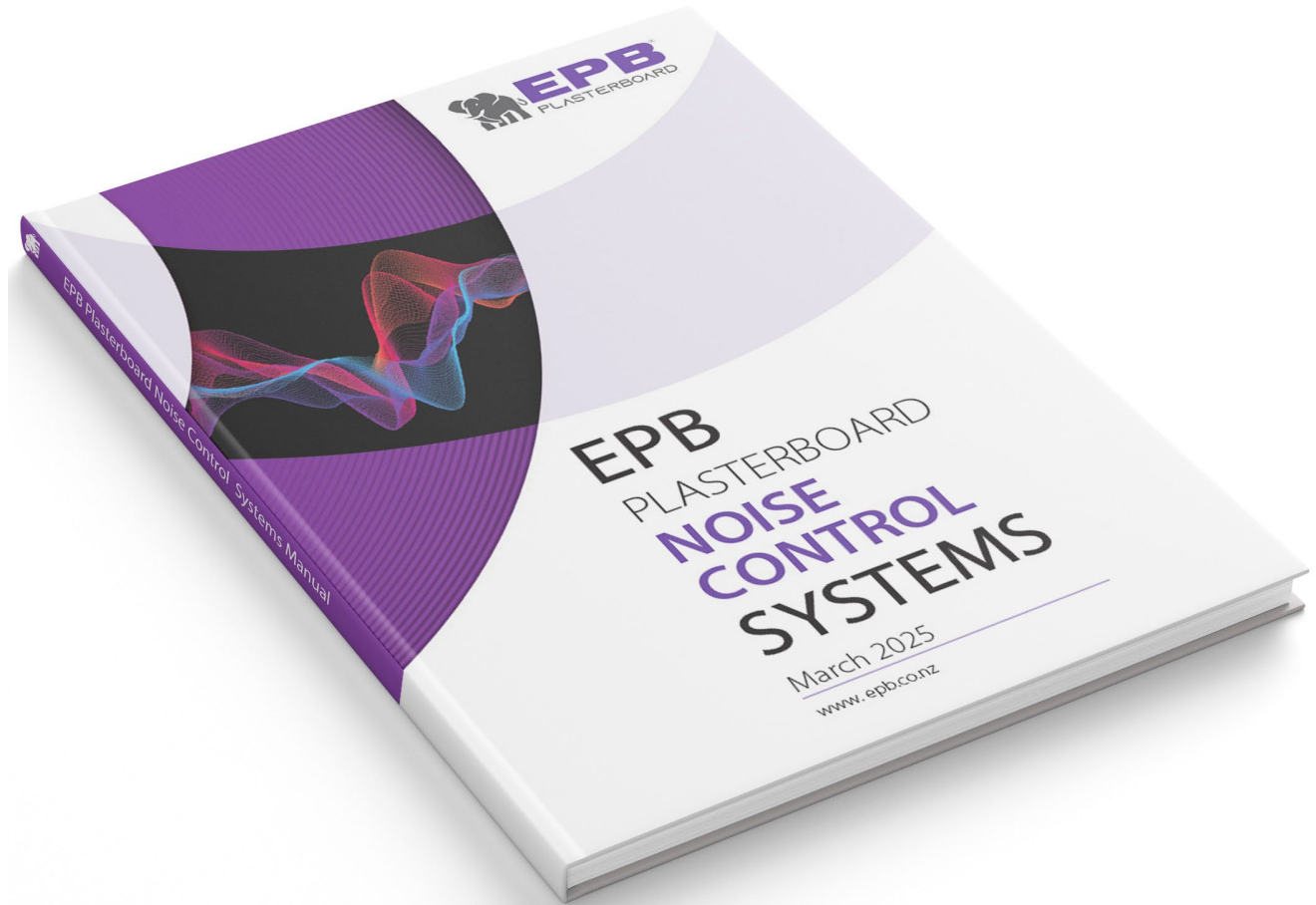

For Noise Control Fire Rated system options, go to

# EPB Plasterboard Noise Control Systems Manual



## Full Intertency - Fire Rated Walls

System Number	Lining Suffix	FRR	Load Bearing Ability	Noise Control		Lining Requirements	Page
				STC	Rw		
<b>Timber Double Frame Walls - Load Bearing</b>							
E3TDLA30	-F30	30/30/30	LB	55	54	1 x 10mm EPB FireSmart® one side 2 x 10mm EPB FireSmart® other side	Please refer to the EPB Plasterboard Fire Rated Systems Manual for these System Specification sheets
	-S39	30/30/30	LB	57	56	1 x 13mm EPB® Standard one side 2 x 13mm EPB® Standard other side	
	-M30	30/30/30	LB	58	57	1 x 10mm EPB MultiSmart® one side 2 x 10mm EPB MultiSmart® other side	
E4TDLA45	-S40	45/45/45	LB	58	57	2 x 10mm EPB® Standard each side	
E2TDLA60	-M26	60/60/60	LB	55	54	1 x 13mm EPB MultiSmart® each side	
E3TDLA60	-MS39	60/60/60	LB	58	57	1 x 13mm EPB MultiSmart® one side 2 x 13mm EPB® Standard other side	
	-M33	60/60/60	LB	59	58	1 x 13mm EPB MultiSmart® one side 2 x 10mm EPB MultiSmart® other side	
	-M39	60/60/60	LB	61	60	1 x 13mm EPB MultiSmart® one side 2 x 13mm EPB MultiSmart® other side	
E4TDLA60	-S46	60/60/60	LB	59	58	1 x 10mm EPB® Standard and 1 x 13mm EPB® Standard each side	
	-F40	60/60/60	LB	60	59	2 x 10mm EPB FireSmart® each side	
	-S52	60/60/60	LB	61	60	2 x 13mm EPB® Standard each side	
	-M40	60/60/60	LB	62	61	2 x 10mm EPB MultiSmart® each side	
E2TDLA75	-F32	75/75/75	LB	56	55	1 x 16mm EPB FireSmart® each side	
E4TDLA90	-F52	90/90/90	LB	64	63	2 x 13mm EPB FireSmart® each side	
	-M52	90/90/90	LB	67	66	2 x 13mm EPB MultiSmart® each side	
<b>Timber Single Frame Walls with Resilient Mount - Load Bearing</b>							
E3TMLA30	-S39	30/30/30	LB	55	54	Framing Side: 1 x 13mm EPB® Standard Mount Side: 2 x 13mm EPB® Standard	
	-M30	30/30/30	LB	56	55	Framing Side: 1 x 10mm EPB MultiSmart® Mount Side: 2 x 10mm EPB MultiSmart®	
E4TMLA30	-F40	30/30/30	LB	58	57	Framing Side: 2 x 10mm EPB FireSmart® Mount Side: 2 x 10mm EPB FireSmart®	
E4TMLA45	-S52	45/45/45	LB	61	60	Framing Side: 2 x 13mm EPB® Standard Mount Side: 2 x 13mm EPB® Standard	
E3TMLA60	-M39	60/60/60	LB	58	57	Framing Side: 1 x 13mm EPB MultiSmart® Mount Side: 2 x 13mm EPB MultiSmart®	
E4TMLA60	-M40	60/60/60	LB	62	61	Framing Side: 2 x 10mm EPB MultiSmart® Mount Side: 2 x 10mm EPB MultiSmart®	
E4TMLA90	-M52	90/90/90	LB	63	62	Framing Side: 2 x 13mm EPB MultiSmart® Mount Side: 2 x 13mm EPB MultiSmart®	
<b>Timber Single Frame Walls with Resilient Rail - Load Bearing</b>							
E4TRLA45	-S52	45/45/45	LB	55	54	Framing Side: 2 x 13mm EPB® Standard Rail Side: 2 x 13mm EPB® Standard	
E4TRLA60	-M40	60/60/60	LB	55	54	Framing Side: 2 x 10mm EPB MultiSmart® Rail Side: 2 x 10mm EPB MultiSmart®	
E4TRLA90	-F52	90/90/90	LB	56	55	Framing Side: 2 x 13mm EPB FireSmart® Rail Side: 2 x 13mm EPB FireSmart®	
	-M52	90/90/90	LB	57	56	Framing Side: 2 x 13mm EPB MultiSmart® Rail Side: 2 x 13mm EPB MultiSmart®	



## Full Intertency - Fire Rated Walls

System Number	Lining Suffix	FRR	Load Bearing Ability	Noise Control		Lining Requirements	Page
				STC	Rw		
<b>Steel Double Frame Walls - Non Load Bearing</b>							
E3SDA30	-S39	-/30/30	NLB	55	54	1 x 13mm EPB® Standard one side 2 x 13mm EPB® Standard other side	
	-M30	-/30/30	NLB	56	55	1 x 10mm EPB MultiSmart® one side 2 x 10mm EPB MultiSmart® other side	
E4SDA45	-F40	-/45/45	NLB	58	57	2 x 10mm EPB FireSmart® each side	
E2SDA60	-M26	-/60/60	NLB	55	54	1 x 13mm EPB MultiSmart® each side	
E3SDA60	-MS39	-/60/60	NLB	57	56	1 x 13mm EPB MultiSmart® one side 2 x 13mm EPB® Standard other side	
	-FM33	-/60/60	NLB	58	57	1 x 13mm EPB FireSmart® one side 2 x 10mm EPB MultiSmart® other side	
	-M33	-/60/60	NLB	58	57	1 x 13mm EPB MultiSmart® one side 2 x 10mm EPB MultiSmart® other side	
	-M39	-/60/60	NLB	61	60	1 x 13mm EPB MultiSmart® one side 2 x 13mm EPB MultiSmart® other side	
E4SDA60	-S52	-/60/60	NLB	61	60	2 x 13mm EPB® Standard each side	
	-M40	-/60/60	NLB	61	60	2 x 10mm EPB MultiSmart® each side	
E2SDA75	-F32	-/75/75	NLB	56	55	1 x 16mm EPB FireSmart® each side	
E4SDA75	-MS52	-/75/75	NLB	63	62	1 x 13mm EPB® Standard and 1x13mm EPB MultiSmart® each side	
E4SDA90	-F52	-/90/90	NLB	62	61	2 x 13mm EPB FireSmart® each side	
	-M46	-/90/90	NLB	63	62	1 x 10mm EPB MultiSmart® and 1 x 13mm EPB MultiSmart® each side	
	-M52	-/90/90	NLB	65	64	2 x 13mm EPB MultiSmart® each side	
<b>Steel Double Frame Walls - Load Bearing</b>							
E2SDLA30	-M26	30/30/30	LB	55	54	1 x 13mm EPB MultiSmart® each side	
	-F32	30/30/30	LB	56	55	1 x 16mm EPB FireSmart® each side	
E3SDLA30	-MF33	30/30/30	LB	58	57	1 x 13mm EPB MultiSmart® one side 2 x 10mm EPB FireSmart® other side	
	-M39	30/30/30	LB	61	60	1 x 13mm EPB MultiSmart® one side 2 x 13mm EPB MultiSmart® other side	
E4SDLA30	-F40	30/30/30	LB	59	58	2 x 10mm EPB® FireSmart each side	
E4SDLA45	-S52	45/45/45	LB	61	60	2 x 13mm EPB® Standard each side	
	-M40	45/45/45	LB	61	60	2 x 10mm EPB MultiSmart® each side	
E4SDLA60	-M52	60/60/60	LB	65	64	2 x 13mm EPB MultiSmart® each side	
E4SDLA90	-F64	90/90/90	LB	66	65	1 x 16mm EPB FireSmart® each side	

Please refer to the EPB Plasterboard Fire Rated Systems Manual for these System Specification sheets



## Full Intertency - Fire Rated Walls

System Number	Lining Suffix	FRR	Load Bearing Ability	Noise Control		Lining Requirements	Page	
				STC	Rw			
<b>Steel Double Frame Walls with FireSmart Central Liner - Non Load Bearing</b>								
E4CSDA60	-MS46	-/60/60	NLB	56	56	1 x 13mm EPB FireSmart and 1 x 10mm EPB Standard each side		
	-MS52	-/60/60	NLB	57	58	1 x 13mm EPB FireSmart And 1 x 13mm EPB Standard each side		
<b>Steel Frame Walls with Resilient Mount - Non Load Bearing</b>								
E3SMA30	-M30	-/30/30	NLB	55	54	Frame Side: 1 x 10mm EPB MultiSmart Mount Side: 2 x 10mm EPB MultiSmart	Please refer to the EPB Plasterboard Fire Rated Systems Manual for these System Specification sheets	
E4SMA30	-F40	-/30/30	NLB	56	55	Frame Side: 2 x 10mm EPB FireSmart Mount Side: 2 x 10mm EPB FireSmart		
E3SMA60	-MS39	-/60/60	NLB	56	55	Frame Side: 1 x 13mm EPB MultiSmart Mount Side: 2 x 13mm EPB Standard		
	-M39	-/60/60	NLB	57	56	Frame Side: 1 x 13mm EPB MultiSmart Mount Side: 2 x 13mm EPB MultiSmart		
E4SMA60	-S52	-/60/60	NLB	58	57	Frame Side: 2 x 13mm EPB Standard Mount Side: 2 x 13mm EPB Standard		
	-M40	-/60/60	NLB	59	58	Frame Side: 2 x 10mm EPB MultiSmart Mount Side: 2 x 10mm EPB MultiSmart		
E4SMA90	-M46	-/90/90	NLB	60	59	Frame Side: 1 x 13mm EPB MultiSmart and 1 x 10mm EPB MultiSmart Mount Side: 1 x 13mm EPB MultiSmart and 1 x 10mm EPB MultiSmart		
	-M52	-/90/90	NLB	62	61	Frame Side: 2 x 13mm EPB MultiSmart Mount Side: 2 x 13mm EPB MultiSmart		
<b>Steel Frame Walls with Resilient Rail - Non Load Bearing</b>								
E4SRA60	-S52	-/60/60	NLB	55	54	Frame Side: 2 x 13mm EPB Standard Rail Side: 2 x 13mm EPB Standard		Please refer to the EPB Plasterboard Fire Rated Systems Manual for these System Specification sheets
	-M40	-/60/60	NLB	56	55	Frame Side: 2 x 10mm EPB MultiSmart Rail Side: 2 x 10mm EPB MultiSmart		
E4SRA90	-M46	-/90/90	NLB	57	56	Frame Side: 1 x 13mm EPB MultiSmart and 1 x 10mm EPB MultiSmart Rail Side: 1 x 13mm EPB MultiSmart and 1 x 10mm EPB MultiSmart		
	-F52	-/90/90	NLB	57	56	Frame Side: 2 x 13mm EPB FireSmart Rail Side: 2 x 13mm EPB FireSmart		
	-M52	-/90/90	NLB	59	58	Frame Side: 2 x 13mm EPB MultiSmart Rail Side: 2 x 13mm EPB MultiSmart		
<b>Quiet Steel Frame Walls - Non Load Bearing</b>								
E4SQA30	-F40	-/30/30	NLB	55	54	2 x 10mm EPB FireSmart each side	Please refer to the EPB Plasterboard Fire Rated Systems Manual for these System Specification sheets	
E4SQA45	-S46	-/45/45	NLB	56	55	1x 10mm EPB Standard and 1 x 13mm Standard each side		
E3SQA60	-M33	-/60/60	NLB	55	54	1 x 13mm EPB MultiSmart one side 2 x 10mm EPB MultiSmart other side		
	-M36	-/60/60	NLB	55	54	1 x 13mm EPB MultiSmart one side 1 x 10mm EPB MultiSmart and 1 x 13mm EPB MultiSmart other side		
	-M39	-/60/60	NLB	57	56	1 x 13mm EPB MultiSmart one side 2 x 13mm EPB MultiSmart other side		
E4SQA60	-S52	-/60/60	NLB	57	56	2 x 13mm EPB Standard each side		
	-M40	-/60/60	NLB	57	56	2 x 10mm EPB MultiSmart each side		
E4SQA75	-MS52	-/75/75	NLB	59	58	1x13mm EPB MultiSmart and 1x13mm EPB Standard each side		
E4SQA90	-M46	-/90/90	NLB	59	58	1 x 10mm EPB MultiSmart and 1 x 13mm EPB MultiSmart each side		
	-M52	-/90/90	NLB	61	60	2 x 13mm EPB MultiSmart each side		



## Full Intertency - Fire Rated Walls

System Number	Lining Suffix	FRR	Load Bearing Ability	Noise Control		Lining Requirements	Page
				STC	Rw		
<b>Staggered Steel Stud Walls - Non Load Bearing</b>							
E3SSA30	-S39	-/30/30	NLB	55	54	1 x 13mm EPB® Standard on One side 2 x 13mm EPB® Standard on Other side	
E4SSA45	-F40	-/45/45	NLB	56	55	2 x 10mm EPB FireSmart® each side	
E3SSA60	-MS39	-/60/60	NLB	56	55	1 x 13mm EPB MultiSmart® one side 2 x 13mm EPB® Standard other side	
	-M39	-/60/60	NLB	57	56	1 x 13mm EPB MultiSmart® one side 2 x 13mm EPB MultiSmart® other side	
E4SSA60	-S52	-/60/60	NLB	59	58	2 x 13mm EPB® Standard each side	
E4SSA90	-M46	-/90/90	NLB	59	58	1 x 10mm EPB MultiSmart® and 1 x 13mm EPB MultiSmart® each side	
	-M52	-/90/90	NLB	62	61	2 x 13mm EPB MultiSmart® each side	

Please refer to the EPB Plasterboard Fire Rated Systems Manual for these System Specification sheets



## Full Intertency - Fire Rated Floor/Ceilings

System Number	Lining Suffix	FRR	Load Bearing Ability	Noise Control			Lining Requirements	Page
				STC	Rw	IIC		
<b>Direct Fix Clip - Floating Floor/Ceiling - Timber Joist</b>								
EFJ2DFA60	-FS26	60/60/60	LB	66	65	57-76	1 x 13mm EPB FireSmart® and 1 x 13mm EPB® Standard	
	-F26	60/60/60	LB	67	66	57-76	2 x 13mm EPB FireSmart®	
	-M26	60/60/60	LB	68	67	57-77	2 x 13mm EPB MultiSmart®	
EFP2DFA60	-FS26	60/60/60	LB	63	62	55-72	1 x 13mm EPB FireSmart® and 1 x 13mm EPB® Standard	
	-F26	60/60/60	LB	64	63	55-72	2 x 13mm EPB FireSmart®	
	-M26	60/60/60	LB	65	64	56-72	2 x 13mm EPB MultiSmart®	
<b>Direct Fix Clip - Floating Floor/Ceiling - Steel Joist</b>								
EFJ2DFsA45	-F26	45/45/45	LB	66	65	56-76	2 x 13mm EPB FireSmart®	
	-M26	45/45/45	LB	67	66	56-76	2 x 13mm EPB MultiSmart®	
EFP2DFsA45	-F26	45/45/45	LB	63	62	55-72	2 x 13mm EPB FireSmart®	
	-M26	45/45/45	LB	64	63	55-72	2 x 13mm EPB MultiSmart®	
EFJ2DFsA60	-F29	60/60/60	LB	67	66	56-76	1 x 13mm EPB FireSmart® and 1 x 16mm EPB FireSmart®	
EFP2DFsA60	-F29	60/60/60	LB	64	63	56-72	1 x 13mm EPB FireSmart® and 1 x 16mm EPB FireSmart®	
<b>Direct Fix Clip - Floor/Ceiling - Timber Joist</b>								
E2DFA60	-FS26	60/60/60	LB	56	55	46-73	1 x 13mm EPB FireSmart® and 1 x 13mm EPB® Standard	
	-F26	60/60/60	LB	57	56	46-73	2 x 13mm EPB FireSmart®	
	-M26	60/60/60	LB	58	57	46-73	2 x 13mm EPB MultiSmart®	
E2DFA90	-FM29	90/90/90	LB	57	56	47-73	1 x 16mm EPB FireSmart® and 1 x 13mm EPB MultiSmart®	
	-F32	90/90/90	LB	58	57	47-73	2 x 16mm EPB FireSmart®	
<b>Suspended Grid Floor/Ceiling - Timber Joist</b>								
E2SCA60	-MS26	60/60/60	LB	56	55	40-72	1 x 13mm EPB MultiSmart® and 1 x 13mm EPB® Standard	
	-F26	60/60/60	LB	56	55	40-72	2 x 13mm EPB FireSmart®	
	-M26	60/60/60	LB	56	55	40-72	2 x 13 EPB MultiSmart®	
E2SCA75	-F29	75/75/75	LB	57	56	47-72	1 x 16mm EPB FireSmart® and 1 x 13mm EPB FireSmart®	
E2SCA90	-F32	90/90/90	LB	57	56	40-73	2 x 16mm EPB FireSmart®	
<b>Direct Fix Clip - Floor/Ceiling - Steel Joist</b>								
E2DFsA45	-F26	45/45/45	LB	56	55	47-74	2 x 13mm EPB FireSmart®	
	-M26	45/45/45	LB	57	56	47-74	2 x 13mm EPB MultiSmart®	
E2DFsA60	-FM29	60/60/60	LB	57	56	47-75	1 x 16mm EPB FireSmart® and 1 x 13mm EPB MultiSmart®	
	-F32	60/60/60	LB	57	56	47-75	2 x 16mm EPB FireSmart®	

Please refer to the EPB Plasterboard Fire Rated Systems Manual for these System Specification sheets



## Sub Intertenancy - Walls

System Number	Lining Suffix	FRR	Load Bearing Ability	Noise Control		Lining Requirements	Page
				STC	Rw		
<b>Single Timber Frame Walls - Load Bearing</b>							
E2TLa30	-S20	30/30/30	LB	39	38	1 x 10mm EPB® Standard each side	Please refer to the EPB Plasterboard Fire Rated Systems Manual for these System Specification sheets
	-S26	30/30/30	LB	40	39	1 x 13mm EPB® Standard each side	
	-M20	30/30/30	LB	41	40	1 x 10mm EPB MultiSmart® each side	
E3TLa30	-S30	30/30/30	LB	42	41	1 x 10mm EPB® Standard one side 2 x 10mm EPB® Standard other side	
	-S39	30/30/30	LB	43	42	1 x 13mm EPB® Standard one side 2 x 13mm EPB® Standard other side	
	-M30	30/30/30	LB	44	43	1 x 10mm EPB MultiSmart® on One side 2 x 10mm EPB MultiSmart® on Other side	
E4TLa45	-S40	45/45/45	LB	44	43	2 x 10mm EPB® Standard each side	
E2TLa60	-M26	60/60/60	LB	42	41	1 x 13mm EPB MultiSmart® each side	
E3TLa60	-MS39	60/60/60	LB	45	44	1 x 13mm EPB MultiSmart® one side 2 x 13mm EPB® Standard other side	
	-M33	60/60/60	LB	45	44	1 x 13mm EPB MultiSmart® one side 2 x 10mm EPB MultiSmart® other side	
	-M39	60/60/60	LB	46	45	1 x 13mm EPB MultiSmart® one side 2 x 13mm EPB MultiSmart® other side	
E4TLa60	-S46	60/60/60	LB	45	44	1 x 10mm EPB® Standard and 1 x 13mm EPB® Standard each side	
	-S52	60/60/60	LB	46	45	2 x 13mm EPB® Standard each side	
	-M40	60/60/60	LB	46	45	2 x 10mm EPB MultiSmart® each side	
E4TLa90	-M52	90/90/90	LB	48	47	2 x 13mm EPB MultiSmart® each side	
<b>Double Timber Frame Walls - Load Bearing</b>							
E2TDLa30	-S20	30/30/30	LB	50	49	1 x 10mm EPB® Standard each side	
	-S26	30/30/30	LB	52	51	1 x 13mm EPB® Standard each side	
	-M20	30/30/30	LB	52	51	1 x 10mm EPB MultiSmart® each side	
<b>Single Timber Frame Walls with Resilient Mount- Load Bearing</b>							
E3TMLa30	-S30	30/30/30	LB	52	51	Frame Side: 1 x 10mm EPB® Standard Mount Side: 2 x 10mm EPB® Standard	
<b>Single Timber Frame Walls with Resilient Rail- Load Bearing</b>							
E3TRLa30	-S30	30/30/30	LB	47	46	Frame Side: 1 x 10mm EPB® Standard Rail Side: 2 x 10mm EPB® Standard	
	-S39	30/30/30	LB	50	49	Frame Side: 1 x 13mm EPB® Standard Rail Side: 2 x 13mm EPB® Standard	
	-M30	30/30/30	LB	51	50	Frame Side: 1 x 10mm EPB MultiSmart® Rail Side: 2 x 10mm EPB MultiSmart®	
E3TRLa60	-MS39	60/60/60	LB	52	50	Frame Side: 1 x 13mm EPB MultiSmart® Rail Side: 2 x 13mm EPB® Standard	
	-M39	60/60/60	LB	52	51	Frame Side: 1 x 13mm EPB MultiSmart® Rail Side: 2 x 13mm EPB MultiSmart®	



## Sub Intertenancy - Walls

System Number	Lining Suffix	FRR	Load Bearing Ability	Noise Control		Lining Requirements	Page	
				STC	Rw			
<b>Single Steel Frame Walls - Non Load Bearing</b>								
E2Sa15	-S20	-/15/15	NLB	40	39	1 x 10mm EPB® Standard each side	Please refer to the EPB Plasterboard Fire Rated Systems Manual for these System Specification sheets	
E2Sa30	-S26	-/30/30	NLB	41	40	1 x 13mm EPB® Standard each side		
	-M20	-/30/30	NLB	42	41	1 x 10mm EPB MultiSmart® each side		
E3Sa30	-S33	-/30/30	NLB	43	42	1 x 13mm EPB® Standard one side 2 x 10mm EPB® Standard other side		
	-S39	-/30/30	NLB	44	42	1 x 13mm EPB® Standard one side 2 x 13mm EPB® Standard other side		
	-M30	-/30/30	NLB	44	43	1 x 10mm EPB MultiSmart® one side 2 x 10mm EPB MultiSmart® other side		
E4Sa45	-S40	-/45/45	NLB	45	44	2 x 10mm EPB® Standard each side		
E2Sa60	-M26	-/60/60	NLB	43	42	1 x 13mm EPB MultiSmart® each side		
E3Sa60	-MS39	-/60/60	NLB	44	43	1 x 13mm EPB MultiSmart® one side 2 x 13mm EPB® Standard other side		
	-M39	-/60/60	NLB	45	44	1 x 13mm EPB MultiSmart® one side 2 x 13mm EPB MultiSmart® other side		
E4Sa60	-S46	-/60/60	NLB	46	45	1 x 10mm EPB® Standard and 1 x 13mm EPB® Standard each side		
	-S52	-/60/60	NLB	48	47	2 x 13mm EPB® Standard each side		
	-M40	-/60/60	NLB	48	47	2 x 10mm EPB MultiSmart® each side		
E4Sa90	-M46	-/90/90	NLB	50	49	1 x 10mm EPB MultiSmart® and 1 x 13mm EPB MultiSmart® each side		
E4Sa105	-M52	-/105/105	NLB	52	51	2 x 13mm EPB MultiSmart® each side		
<b>Single Steel Frame Walls - Load Bearing</b>								
E2SLa30	-M26	30/30/30	LB	43	42	1 x 13mm EPB MultiSmart® each side		
E3SLa30	-M39	30/30/30	LB	45	44	1 x 13mm EPB MultiSmart® one side 2 x 13mm EPB MultiSmart® other side		
E4SLa30	-S40	30/30/30	LB	45	44	2 x 10mm EPB® Standard each side		
E4SLa45	-S52	45/45/45	LB	48	47	2 x 13mm EPB® Standard each side		
	-M40	45/45/45	LB	48	47	2 x 10mm EPB MultiSmart® each side		
E4SLa60	-M52	60/60/60	LB	52	51	2 x 13mm EPB MultiSmart® each side		
E4SLa90	-F64	90/90/90	LB	53	52	2 x 16mm EPB FireSmart® each side		
<b>Double Steel Frame Walls - Non Load Bearing</b>								
E2SDa30	-S26	-/30/30	NLB	52	51	1 x 13mm EPB® Standard each side		
	-M20	-/30/30	NLB	52	51	1 x 10mm EPB MultiSmart® each side		



## Sub Intertenancy - Walls

System Number	Lining Suffix	FRR	Load Bearing Ability	Noise Control		Lining Requirements	Page
				STC	Rw		
<b>Steel Frame Walls with Resilient Rail- Non Load Bearing</b>							
E3SRa30	-S39	-/30/30	NLB	51	50	Frame Side: 1 x 13mm EPB® Standard Rail Side: 2 x 13mm EPB® Standard	
	-M30	-/30/30	NLB	51	50	Frame Side: 1 x 10mm EPB MultiSmart® Rail Side: 2 x 10mm EPB MultiSmart®	
E3SRa60	-MS39	-/60/60	NLB	52	51	Frame Side: 1 x 13mm EPB MultiSmart® Rail Side: 2 x 13mm EPB® Standard	
	-M39	-/60/60	NLB	53	52	Frame Side: 1 x 13mm EPB MultiSmart® Rail Side: 2 x 13mm EPB MultiSmart®	
<b>Quiet Steel Frame Walls - Non Load Bearing</b>							
E2SQa30	-S26	-/30/30	NLB	47	46	1 x 13mm EPB® Standard each side	
	-M20	-/30/30	NLB	48	47	1 x 10mm EPB MultiSmart® each side	
E3SQa30	-S39	-/30/30	NLB	53	52	1 x 13mm EPB® Standard one side 2 x 13mm EPB® Standard other side	
	-M30	-/30/30	NLB	53	52	1 x 10mm EPB MultiSmart® one side 2 x 10mm EPB MultiSmart® other side	
E3SQa45	-MS33	-/45/45	NLB	52	51	1 x 13mm EPB MultiSmart® one side 2 x 10mm EPB® Standard other side	
E2SQa60	-M26	-/60/60	NLB	50	49	1 x 13mm EPB MultiSmart® each side	
<b>Staggered Steel Stud Walls - Non Load Bearing</b>							
E2SSa30	-S26	-/30/30	NLB	50	49	1 x 13mm EPB® Standard each side	
	-M20	-/30/30	NLB	49	48	1 x 10mm EPB MultiSmart® each side	
E2SSa60	-M26	-/60/60	NLB	52	51	1 x 13mm EPB MultiSmart® each side	
	-F32	-/60/60	NLB	54	53	1 x 16mm EPB FireSmart® each side	

Please refer to the EPB Plasterboard Fire Rated Systems Manual for these System Specification sheets

## Sub Intertenancy - Floor/Ceilings

System Number	Lining Suffix	FRR	Load Bearing Ability	Noise Control			Lining Requirements
				STC	Rw	IIC	
<b>Direct Fix Clip - Floor/Ceiling</b>							
E1DFa15	-S13	15/15/15	LB	48	47	43-69	1 x 13mm EPB® Standard
E2DFa30	-S26	30/30/30	LB	53	52	43-69	2 x 13mm EPB® Standard
E1DFa45	-M13	45/45/45	LB	52	51	43-69	1 x 13mm EPB MultiSmart®
E1DFa60	-F16	60/60/60	LB	52	51	43-69	1 x 16mm EPB FireSmart®
<b>Suspended Grid Floor/Ceiling</b>							
E1SCa15	-S13	15/15/15	LB	48	47	39-62	1 x 13mm EPB® Standard
E2SCa30	-S26	30/30/30	LB	53	52	42-67	2 x 13mm EPB® Standard
E1SCa45	-M13	45/45/45	LB	51	50	43-69	1 x 13mm EPB MultiSmart®
E1SCa60	-F16	60/60/60	LB	52	51	43-69	1 x 16mm EPB FireSmart®





For Plasterboard & Fibre Cement combination Fire Rated system options, go to

# EPB Plasterboard & Fibre Cement Fire Rated Systems Manual

## External Fire Rated Walls - Timber Frame

System Number	Lining Suffix	FRR	Insulation	Noise Control STC	Lining Requirements	Page
<b>EPB Plasterboard &amp; James Hardie Linea™ Weatherboard</b>						
EJL1TL30	-F10	30/30/30	R2.2 glass wool	46	1 x 10mm EPB FireSmart® on Internal side James Hardie Linea™ Weatherboard to External side	
EJL1TL60	-F13	60/60/60	R2.2 glass wool	47	1 x 13mm EPB FireSmart on Internal side James Hardie Linea™ Weatherboard to External side	
<b>EPB Plasterboard &amp; James Hardie Oblique™ Weatherboard</b>						
EJOH1TL30	-F10	30/30/30	R2.2 glass wool	46	1 x 10mm EPB FireSmart® on Internal side James Hardie Oblique™ Weatherboard horizontal to External side	
EJOv1TL30	-F10	30/30/30	R2.2 glass wool	46	1 x 10mm EPB FireSmart® on Internal side James Hardie Oblique™ Weatherboard vertical to External side	
EJOH1TL60	-F13	60/60/60	R2.2 glass wool	47	1 x 13mm EPB FireSmart® on Internal side James Hardie Oblique™ Weatherboard horizontal to External side	
EJOv1TL60	-F13	60/60/60	R2.2 glass wool	47	1 x 13mm EPB FireSmart on Internal side James Hardie Oblique™ Weatherboard vertical to External side	
<b>EPB Plasterboard &amp; James Hardie™ Plank Weatherboard</b>						
EJW1TL30	-F10	30/30/30	R2.2 glass wool	45	1 x 10mm EPB FireSmart® on Internal side James Hardie™ Plank Weatherboard to External side	
EJW1TL60	-F13	60/60/60	Hardie™ Mineral	46	1 x 13mm EPB FireSmart® on Internal side James Hardie™ Plank Weatherboard to External side	
<b>EPB Plasterboard &amp; James Hardie Stria™ Cladding</b>						
EJSh1TL30	-F10	30/30/30	R2.2 glass wool	46	1 x 10mm EPB FireSmart® on Internal side James Hardie Stria™ Cladding horizontal to External side	
EJSv1TL30	-F10	30/30/30	R2.2 glass wool	46	1 x 10mm EPB FireSmart® on Internal side James Hardie Stria™ Cladding vertical to External side	
EJSh1TL60	-F13	60/60/60	R2.2 glass wool	47	1 x 13mm EPB FireSmart® on Internal side James Hardie Stria™ Cladding horizontal to External side	
EJSv1TL60	-F13	60/60/60	R2.2 glass wool	47	1 x 13mm EPB FireSmart® on Internal side James Hardie Stria™ Cladding vertical to External side	
<b>EPB Plasterboard &amp; James Hardie Stria™ Cladding &amp; RAB™ Board with CLD Battens</b>						
EJRS1TL30	-F10	30/30/30	R2.2 glass wool	46	1 x 10mm EPB FireSmart on Internal side James Hardie Stria™ Cladding and RAB™ Board with CLD™ Structural Cavity Batten to External side	
EJRS1TL60	-F13	60/60/60	Hardie™ Mineral	47	1 x 13mm EPB FireSmart on Internal side James Hardie Stria™ Cladding and RAB™ Board with CLD™ Structural Cavity Batten to External side	
<b>EPB Plasterboard &amp; James Hardie Hardie™ Flex Sheet</b>						
EJF1TL30	-F10	30/30/30	R2.2 glass wool	42	1 x 10mm EPB FireSmart® on Internal side James Hardie Hardie™ Flex Sheet to External side	
EJF1TL60	-F13	60/60/60	Hardie™ Mineral	43	1 x 13mm EPB FireSmart® on Internal side James Hardie Hardie™ Flex Sheet to External side	

Please refer to the EPB Plasterboard Fire Rated Systems Manual for these System Specification sheets



## External Fire Rated Walls - Timber Frame

System Number	Lining Suffix	FRR	Insulation	Noise Control STC	Lining Requirements	Page
<b>EPB Plasterboard &amp; James Hardie Axon™ Panel</b>						
EJA1TL30	-F10	30/30/30	R2.2 glass wool	41	1 x 10mm EPB FireSmart® on Internal side James Hardie Axon™ Panel to External side	
EJA1TL60	-F13	60/60/60	Hardie™ Mineral	42	1 x 13mm EPB FireSmart® on Internal side James Hardie Axon™ Panel to External side	
<b>EPB Plasterboard &amp; James Hardie Axon™ Panel &amp; RAB™ Board with CLD Battens</b>						
EJRA1TL30	-F10	30/30/30	R2.2 glass wool	45	1 x 10mm EPB FireSmart® on Internal side James Hardie Axon™ Panel and RAB™ Board with CLD™ Structural Cavity Batten to External side	
EJRA1TL60	-F13	60/60/60	Hardie™ Mineral	46	1 x 13mm EPB FireSmart® on One side James Hardie Axon™ Panel and RAB™ Board with CLD™ Structural Cavity Batten to External side	
<b>EPB Plasterboard &amp; James Hardie ExoTec™ Facade Panel &amp; RAB™ Board</b>						
EJRX1TL30	-F10	30/30/30	R2.2 glass wool	47	1 x 10mm EPB FireSmart® on Internal side James Hardie ExoTec™ Facade Panel and RAB™ Board with Top hat system to External side	
EJRX1TL60	-F13	60/60/60	Hardie™ Mineral	48	1 x 13mm EPB FireSmart® on Internal side James Hardie ExoTec™ Facade Panel and RAB™ Board with Top hat system to External side	
<b>EPB Plasterboard &amp; James Hardie RAB™ Board &amp; a Weathertight Cladding (See Note 1)</b>						
EJRN1TL30	-F10	30/30/30	R2.2 glass wool	42	1 x 10mm EPB FireSmart® on Internal side James Hardie RAB™ Board with a Weathertight Cladding to External side	
EJRN1TL60	-F13	60/60/60	Hardie™ Mineral	42	1 x 13mm EPB FireSmart® on Internal side James Hardie RAB™ Board with a Weathertight Cladding to External side	
EJRN2TL60	-F20	60/60/60	Hardie™ Mineral	46	2 x 10mm EPB FireSmart® on Internal side James Hardie RAB™ Board with a Weathertight Cladding to External side	
	-S26	60/60/60	Hardie™ Mineral	47	2 x 13mm EPB® Standard on Internal side James Hardie RAB™ Board with a Weathertight Cladding to External side	
	-M20	60/60/60	Hardie™ Mineral	47	2 x 10mm EPB MultiSmart® on Internal side James Hardie RAB™ Board with a Weathertight Cladding to External side	

Please refer to the EPB Plasterboard Fire Rated Systems Manual for these System Specification sheets



## External Fire Rated Walls - Steel Frame

System Number	Lining Suffix	FRR	Insulation	Noise Control		Lining Requirements	Page
				STC	IIC		

EPB Plasterboard & RAB™ board with Selected James Hardie Fibre Cement Cladding							
EJRH1SL30	-F16	30/30/30	Hardie™ Mineral	42 - 47		1 x 16mm EPB FireSmart® on Internal side James Hardie RAB™ Board with Selected James Hardie Fibre Cement cladding to External side	
EJRH2SL30	-F20	30/30/30	Hardie™ Mineral	47 - 53		2 x 10mm EPB FireSmart® on Internal side James Hardie RAB™ Board with Selected James Hardie Fibre Cement cladding to External side	
EJRH2SL60	-F26	60/60/60	Hardie™ Mineral	51 - 54		2 x 13mm EPB FireSmart® on Internal side James Hardie RAB™ Board with Selected James Hardie Fibre Cement cladding to External side	

EPB Plasterboard & James Hardie RAB™ Board & a Weathertight Cladding (See Note 1)							
EJRN1SL30	-F16	30/30/30	Hardie™ Mineral	43		1 x 16mm EPB FireSmart® on Internal side James Hardie RAB™ Board with a Weathertight Cladding to External side	
EJRN2SL30	-F20	30/30/30	Hardie™ Mineral	47		2 x 10mm EPB FireSmart® on Internal side James Hardie RAB™ Board with a Weathertight Cladding to External side	
EJRN2SL60	-F26	60/60/60	Hardie™ Mineral	49		2 x 13mm EPB FireSmart® on Internal side James Hardie RAB™ Board with a Weathertight Cladding to External side	

## Internal Fire Rated Walls - Timber Frame

System Number	Lining Suffix	FRR	Insulation	Noise Control		Lining Requirements	
				STC	IIC		
EPB Plasterboard & James Hardie Villaboard™ Lining							
EJV1TL30	-F10	30/30/30	R2.2 glass wool	42		1 x 10mm EPB FireSmart® one side James Hardie Villaboard™ Lining other side	
EJV1TL60	-F13	60/60/60	Hardie™ Mineral	43		1 x 13mm EPB FireSmart® one side James Hardie Villaboard™ Lining other side	

## Floor/Ceilings - Timber Frame

System Number	Lining Suffix	FRR	Insulation	Noise Control		Lining Requirements to underside of Frame	
				STC	IIC		
EPB Plasterboard & James Hardie Secura™ Interior Flooring							
EJS1FC30	-F13	30/30/30	R1.8 glass wool	45	33	1 x 13mm EPB FireSmart® to underside of frame	
EJS1FC60	-F16	60/60/60	n/a	46	33	1 x 16mm EPB FireSmart® to underside of frame	

## Full Intertenancy - Floating Floor/Ceilings - Timber Frame

System Number	Lining Suffix	FRR	Insulation	Noise Control		Lining Requirements to underside of Frame	
				STC	IIC		
EPB Plasterboard & Floating James Hardie Secura™ Interior Flooring							
EFJ2DFA60	-FS26	60/60/60	R1.8 glass wool	67	57-76	1 x 13 EPB FireSmart® And 1 x 13 EPB® Standard under the battens	
	-F26	60/60/60	R1.8 glass wool	68	57-77	2 x 13 EPB FireSmart® under the battens	

Please refer to the EPB Plasterboard Fire Rated Systems Manual for these System Specification sheets



## INTRODUCTION

This manual provides details for construction of One way and Two way Fire Rated walls and floor/ceiling elements to provide fire protection as required by the NZBC clause C1 to C6 "Protection From Fire".

Elephant Plasterboard (NZ) Limited has many different combinations of wall and ceiling Fire Rated Systems. It is the responsibility of the specifier to accommodate the required performance of the building they are considering. The specifier should take into consideration both external and internal fire rating for occupants intended use. Special consideration must be taken in the construction process.

All construction details that have been provided in this manual are generic only and it is important that expert advice is sought to determine suitability in each individual project

### Limitations and Conditions of Use

- EPB Plasterboard is intended for normal conditions of dry internal use.
- EPB Plasterboard must not be used for bracing applications in or around baths and shower areas.
- EPB Plasterboard must not be exposed to liquid water or be installed in situations where extended exposures to humidity above 90% Relative Humidity are to be expected. Bathrooms, kitchens and laundries should have adequate ventilation or heating to avoid condensation build-up.
- A suitable surface finish (e.g. Vinyl wallpaper or gloss and semi-gloss alkyd paints) must be applied to EPB Plasterboard in all areas where liquid water or high humidity can be expected.
- EPB Plasterboard must not be installed over a vapour barrier.
- EPB Plasterboard must not be applied directly to masonry, concrete or solid plaster, unless timber strapping or steel furring channels are used.
- EPB Plasterboard must not be exposed to temperatures of 52°C or greater for prolonged periods.
- EPB Plasterboard may not be used as an external lining.

### New Zealand Building Code (NZBC) Compliance

EPB Plasterboard is manufactured to AS/NZS 2588 and has been specifically formulated to meet New Zealand Building Code requirements. EPB Plasterboard has been marketed internationally since 1975 and the product has established an excellent history of performance for its use in buildings throughout New Zealand and the Asia/Pacific region. EPB Plasterboard meets the durability requirements of the NZBC and is subject to use, installation and maintenance in accordance with the instructions outlined in this manual. The Manufacturing plant is International Standard ISO 9001 and ISO 14001 registered.

- **NZBC Clause B1 Structure:**  
Framing material specifications used with EPB Plasterboard Systems must be in accordance with the performance requirements of NZBC Clause B1. Timber framed walls and floors must be installed and meet the requirements of NZS3604.
- **NZBC Clause B2 Durability:**  
EPB Plasterboard Fire, Noise Control & Bracing Systems have a serviceable life of not less than 50 years and so is in accordance to NZBC B2.3.1.
- **NZBC Clause C1-C6 Protection from Fire:**  
EPB Plasterboard Fire & Noise Control Systems can meet the requirements of providing passive fire protection as per NZBC Clause C1-C6.
- **NZBC Clause E3 Internal Moisture:**  
EPB Plasterboard Wet Area Systems can meet the requirements of NZBC Acceptable Solution E3/AS1.
- **NZBC Clause F2 Hazardous Building Materials:**  
EPB Plasterboard Systems meet this requirement of NZBC Clause F2 and will not present a health hazard to people.
- **NZBC Clause G6 -Airborne & Impact Sound:**  
EPB Plasterboard Noise Control Systems entitled 'Full Intertency' (STC 55 or greater) systems meet the requirements of NZBC Clause G6.



## INTRODUCTION

### Fire Resistance Ratings (FRR)

To prevent fire spread or structural collapse, the Acceptable Solutions require building elements to have fire resistance ratings (FRR). The level of FRR required depends on the risk group of the building. The way to determine the FRR of building elements is by using the standard tests specified in Appendix C of the Acceptable Solutions.

#### FRR components

An FRR comprises three numbers: these give time values in minutes for structural adequacy, integrity and insulation. E.g. --/60/60 (a/b/c). Primary and secondary elements required to have an FRR will, depending on their function, need to satisfy one or more of these three criteria as follows:

- a) **Structural Adequacy:** usually provided by primary elements within a fire cell. These include building elements which are part of the structure, and those providing support to other elements with an FRR within the same or adjacent fire cells. Examples are: columns, beams, floors and walls (which may also be fire separations). Paragraph 4.3 of the Acceptable Solutions describes special situations where primary elements need not have an FRR.
- b) **Integrity:** usually provided by secondary elements. Examples are fire separations, which are internal partitions and floors, areas of external walls not permitted to be an unprotected area, and some areas of roofs when close to another building or crossed by an exit way. Primary elements forming an integral part of a fire separation are also rated for integrity.
- c) **Insulation:** applies to fire separations and is required where the transmission of heat through the element may endanger occupants on the other side or cause fire to spread to other fire cells or adjacent buildings. For example, insulation is necessary for fire separations between sleeping spaces, where protecting a safe path or through external walls.

EPB Plasterboard Fire Rated Systems meet the requirements of the above clauses and definitions and have numerous systems combinations as outlined in this manual. All EPB Plasterboard Fire Rated systems have been tested or internally assessed or have opinions provided by independent accredited quality assurance organisations like "The Building Research Association of New Zealand (BRANZ)".

### Internal Lining Surface Finish Properties

EPB Plasterboard has been tested at BRANZ in accordance with ISO 5660 Reaction to fire tests (Heat release, smoke production and mass loss rate) Part 1: Heat release rate (cone calorimeter method); and ISO 5660 Reaction to fire tests (Heat release, smoke production and mass loss rate) Part 2: Smoke production rate (dynamic measurement).

A Group Number Classification of 1-S was achieved in Fire test FH 5695-TT for all EPB Plasterboard paper faced sheet linings. This classification only applies to EPB Plasterboard paper faced sheet linings without paint or wallpaper finish. Contact the surface finish suppliers for group number information for their products.

'Group Number 1-S' is the highest performance expectation under 'Part 4. Control of Internal Fire and Smoke Spread' clause C/AS2 to C/AS7 of the NZBC. It means an EPB Plasterboard paper faced sheet lining can be specified for use in any risk group application.

### Fire Rated Walls

EPB Plasterboard Fire Rated Systems have been tested on timber & steel frame walls, either as Load Bearing (LB) or Non Load Bearing.

#### Timber Frame

Stud heights, stud spacings, load and framing dimensions for Load Bearing (LB) or Non Load Bearing (NLB) Timber framed walls are determined by the NZBC, and NZS3604. Heights greater than what is defined in NZS3604 will need specific design by a structural engineer.

#### Steel Frame

Stud heights, stud spacings, load and framing dimensions for Load Bearing (LB) or Non Load Bearing (NLB) Steel framed walls need consultation with the framing supplier or fire engineer for fire design serviceability criteria.

#### General

Maximum spacing of studs 600mm centres. Wall linings must be mechanically fixed. Glue may not be substituted for mechanical fixing if used in a passive fire system. Screw lengths, spacings and type as defined by this manual must be used. Sheet edges must be fixed over studs when placed vertically or over solid blocking when placed horizontally. All outer layers must be stopped to a minimum level 3 stopping (refer to EPB Plasterboard Installation Guide). Ensure the outer wall sheet is staggered minimum 300mm centres from the first sheet and that it is placed behind an adjacent stud. If a fire rated sealant is required ensure that the sealant is of the same FRR as the specified system in use and that it has been independently tested.



## Fire Resistance of Clad Walls

### External Walls

When using EPB Plasterboard externally for a fire system, the board should be protected by a suitable weathertight cladding.

EPB Plasterboard's FRR remains unaffected by the external cladding, provided the exterior cladding complies with NZBC Clause C1-6 protection of fire and in particular It is also important to consider that the fire properties of the external cladding is in accordance with NZBC C/VM1 or C/AS documents. Refer to Table 5.1 of Section 5.4 of C/AS1 and Table 5.5 of Section 5.8.1 of C/AS2 for the information about various risk groups to identify the external fire spread safety requirement applicable to the exterior surface finishes.

External cladding systems must comply with NZBC E2/AS1.

All external walls must have a flexible underlay or a rigid air barrier and be installed with a drained cavity.

### Internal or External Walls

EPB Plasterboard joints and screw heads may be left unstopped if the wall is clad with one of the following materials:

- Timber or wood based products
- Fibre Cement sheeting
- Steel sheeting (flat or profiled)
- EIFS (Exterior insulation and finish systems)

### Internal Walls

- All the above
- 10mm or thicker plasterboard of any type

## Structural Steel Members located inside cavities of Two way Fire Rated Wall or Floor/Ceiling systems

Structural steel members such as columns or beams are sometimes located inside the cavities of two way fire rated wall or floor/ceiling systems. The FRR of the two way fire rated system applies across the entire element, from exposed side to the unexposed side. The temperature inside the cavity can rise above the critical temperature level for structural steel members resulting in premature buckling. Therefore by containing a structural steel member within a two way fire system, it cannot be automatically assumed that the structural steel member will maintain its structural integrity of the two way fire system within which it is contained. For guidance on the protection of structural steel members, refer to the columns and beams section of this document

## Universal Walls (One Way FRR Systems)

EPB Plasterboard Fire Rated systems may be used for a Universal wall. By definition a Universal wall is a wall that is further away than a boundary wall i.e. greater than 1.0 meter. Cladding is a requirement. Note limitations in each fire system in regard to cladding that contain foamed polymers.

Walls closer than 1 metre generally need to be Two Way FRR systems and require a suitable fire rated cladding or plasterboard on the exterior and then a suitable water tight cladding system over the top. (See Boundary Walls section) .

The building code (NZBC) under C2 part 5.2 and tables 5.2 and 5.3 stipulates distances from a delineated boundary and recommends the required fire protection as a percentage of exposed property wall. FRR ratings are required for Structural Adequacy and Integrity. Insulation to the wall is not considered, as fire penetration will spread to the exterior walls through windows and unprotected FRR walls.

## EPB QuickBrace System

The bracing systems specified in the EPB QuickBrace Systems Manual can easily be combined with the EPB Fire Rated Systems by adhering to the details outlined for the relevant Bracing system type and relevant Fire Rated System requirements.

For Single layered Fire Rated systems, use the QuickBrace fastening pattern and the required screw length of the Fire Rated Systems.

For Double layered Fire Rated systems, the bracing sheet can be either:

- The Inner sheet fixed directly to the framing. Use the QuickBrace fastening pattern and the required screw length of the Fire Rated System. The inner layer can be left unstopped; or
- The Outer sheet. Use the QuickBrace fastening pattern and the required screw length of the Fire Rated System.

For Resilient Rail or Resilient Mount systems, only single sided bracing systems can be used e.g. ER1, ES-N, ES-H and EM-H. The bracing sheet must be placed directly against the framing and not on the rail or mount side. Use the QuickBrace fastening pattern and the required screw length of the Fire Rated System.

## Fire Rated Floor/Ceiling

EPB Plasterboard Fire Rated Systems have been tested on Load bearing floor/ceiling systems. Refer to this manual for fixings and layer combinations. Ceiling linings must be mechanically fixed. Glue may not be substituted for mechanical fixing if used in a passive fire system. Screw lengths, spacings and type as defined by this manual must be used.

### Timber & Composite Joists

Floor/ceiling system as defined in NZS3604 for floor loadings (2.0 kPa or 3.0 kPa) may be used. Consult NZS 3604 latest edition for floor joist spans. Floor joists must have a minimum of 190mm depth x 45mm width and a maximum spacing of 600mm centres. Alternatively, proprietary composite joist systems may be used. Consult the appropriate supplier's technical information for design strength and serviceability.

### Steel Joists

Steel floor joists shall be a minimum depth of 190mm C- section with 45mm flanges and a steel gauge of 1.6mm minimum. Joists to be spaced at no more than 600mm centres.

### Flooring

Floor/Ceiling system must have a floor that is at least 20mm thick particle board complying with AS/NZS 1860 Part 1: 2017 or minimum 17mm thick structural ply complying with AS/NZS 2269 Part 0: 2012 fixed to the floor joists as per manufacturer's installation instructions.

Existing Tongue & Groove flooring of minimum 20mm thickness that is tight and in good condition is also allowed.

### Suspended Grid Ceiling

Rondo® KEY-LOCK™ steel frame suspension system comprising 2.5mm wire hangers spaced at 1200mm centres may be used. Supporting strong back channels to be spaced at a minimum of 1200mm centres and furring channels to be spaced at a maximum of 600mm centres. Refer to "Rondo Drywall Grid Suspension System" installation manual. Any alternative suspension system with at least equivalent layout and material properties, strength and stiffness may also be used.

## Universal Ceiling Systems( One Way FRR)

EPB Plasterboard Fire Rated systems may be used as a Universal ceiling system. By definition a Universal ceiling system is a ceiling without a floor above. Universal ceiling systems are usually ceiling joists, rafters and bottom cords of a truss roof. Universal ceiling systems can be either timber or steel with or without battens, may have a suspended clip system with timber or steel battens secured to the bottom of the universal ceiling. Refer to this manual for exact fixings and layer combinations.

## Acoustic Sealant

In order to achieve the published STC performances in this manual, a bead of acoustic sealant must be placed around the perimeter of the framing or the inner layer and the outer layer is bedded into the bead.

## Impact Insulation Class

The IIC rating stated in the EPB plasterboard floor/ceiling systems are based on a bare floor finish.



### Load Bearing Steel Studs

The steel frame design shall meet the structural criteria for strength and serviceability under dead and live loads. Frame heights, stud spacings and stud type are determined by specific engineering design. Stud spacings shall be 600 centres maximum. Stud width shall be 35mm minimum. Refer to the relevant sections of this Manual, in order to obtain the lining requirements to achieve the equivalent FRR of load bearing steel stud walls.

### Non Load Bearing Steel Studs

Specific design for serviceability and fire design criteria is required for greater wall heights than the limit stated in the relevant systems of this Manual. Consult the framing manufacturer for the serviceability design criteria. Nogs in accordance with the framing supplier.



### Product & Component Substitution

When a product specified in a system as per this manual is substituted, the performance of the system will be compromised. Therefore the materials specified in the system must not be substituted. Elephant Plasterboard (NZ) Limited does not take any liability if substitution of components are implemented in any EPB Plasterboard Systems without consultation.

### Plasterboard Substitution Options

The table below indicates which products can substitute the original plasterboard type specified.

- ✓ indicates that the FRR performance will be maintained
- X indicates that the FRR performance will be lower and so therefore the substitution is not allowed

Original EPB Plasterboard specified	EPB Plasterboard Substitution Options - FRR performance								
	Standard		FireSmart			MultiSmart		AquaSmart	
	10mm	13mm	10mm	13mm	16mm	10mm	13mm	10mm	13mm
10mm EPB® Standard	-	✓	✓	✓	✓	✓	✓	✓	✓
13mm EPB® Standard	X	-	X	✓	✓	✓	✓	✓ <sup>1</sup>	✓
10mm EPB FireSmart®	X	✓	-	✓	✓	✓	✓	✓	✓
13mm EPB FireSmart®	X	X	X	-	✓	X	✓	X	✓
16mm EPB FireSmart®	X	X	X	X	-	X	X	X	X
10mm EPB MultiSmart®	X	X	X	✓	✓	-	✓	✓ <sup>1</sup>	✓
13mm EPB MultiSmart®	X	X	X	X	✓	X	-	X	✓ <sup>1</sup>

Note 1 : See table below for STC reduction when substituting

The table below details the reduction in STC performance when substituting original specified plasterboard with EPB AquaSmart®

- ✓ indicates that the FRR & STC performance will be maintained
- X indicates that the FRR performance will be lower and so therefore the substitution is not allowed

Original EPB Plasterboard specified	STC performance			
	10mm AquaSmart		13mm AquaSmart	
	Single layer One side	Single Layer Both sides	Single layer One side	Single Layer Both sides
10mm EPB® Standard	✓	✓	✓	✓
13mm EPB® Standard	Reduced by 1 STC	Reduced by 2 STC	✓	✓
10mm EPB FireSmart®	✓	✓	✓	✓
13mm EPB FireSmart®	X	X	✓	✓
16mm EPB FireSmart®	X	X	X	X
10mm EPB MultiSmart®	Reduced by 1 STC	Reduced by 2 STC	✓	✓
13mm EPB MultiSmart®	X	X	Reduced by 1 STC	Reduced by 2 STC



## Nomenclature:

### EPB Specification Reference

#### Wall Systems

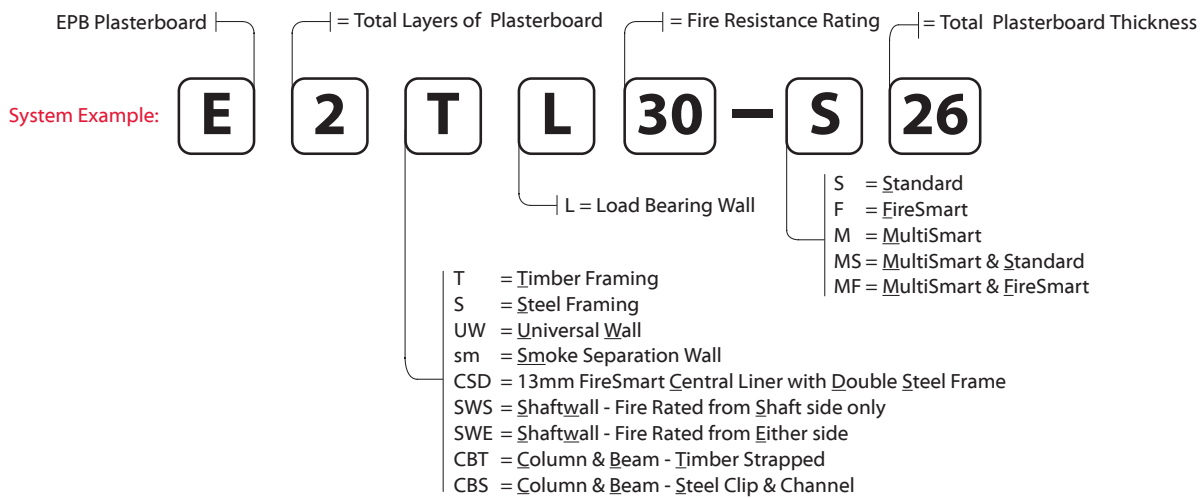

#### Floor/Ceiling Systems

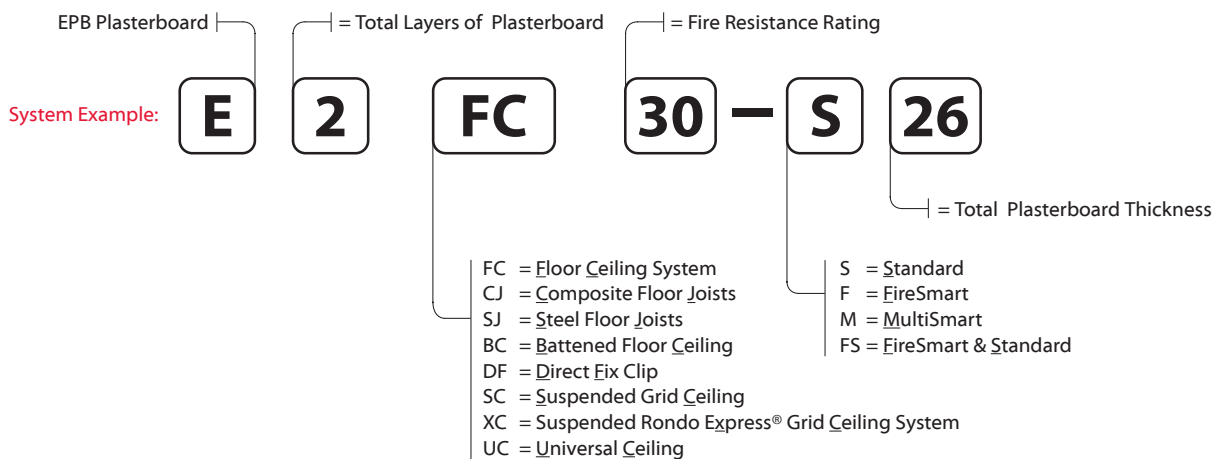

2 Layers: 1 Layer of Plasterboard to each side of frame

System Number	Lining Suffix	Fire Rating	Load Bearing Ability	Noise Control		Lining Requirement
				STC	Rw	
E2TL30	-S20	30/30/30	LB	37	36	1 x 10mm EPB® Standard on One side 1 x 10mm EPB® Standard to Other side
	-F20	30/30/30	LB	37	36	1 x 10mm EPB FireSmart® on One side 1 x 10mm EPB FireSmart® to Other side
	-S26	30/30/30	LB	37	36	1 x 13mm EPB® Standard on One side 1 x 13mm EPB® Standard to Other side

**Framing**

Framing to comply with relevant sections and clauses of NZBC B1: Structure and NZBC B2: Durability.

Studs at 600mm centres maximum.

Nogs at 1200mm centre maximum.

**Wall Height, Load and Framing Dimensions**

These are determined by NZS 3604 stud tables for load bearing or non-load bearing partitions.

**Plasterboard Lining**

**NB:** The installer must look for the Product Identification Code on the face paper to ensure the correct board type is installed. Refer to the Face Paper Product Identification Code table on this page.

One layer of EPB® Plasterboard lining as per specified system above on each side of the timber framing.

Vertical or Horizontal fixing permitted. Use full height or full length sheets where possible.

**For Vertical Fixing-** the vertical sheet joints must be offset on the opposite side of the frame.

**For Horizontal Fixing-** the horizontal sheet joints on the opposite side of the frame can be formed over the same row of nogs.

**Sheet end butt joints-** must be formed over framing, offset from opposite side of the frame.

All sheet joints must be fixed over solid timber framing. Sheets shall be touch fitted.

**Fixing of Linings**

**Fasteners (As per Specified System Above)**

System Number	Side One	Side Two
	High Thread Drywall Screws	
E2TL30-S20 E2TL30-F20	10mm	10mm
E2TL30-S26	41 x 6g	41 x 6g
	13mm	13mm
	41 x 6g	41 x 6g

**Fastener Centres**

Fix at 300mm centres at sheet perimeters, on top and bottom plates and 300mm centres up all studs.

Place fasteners no closer than 12mm from the sheet edges and 18mm from sheet ends.

Place fasteners 50mm from sheet corners along the top and bottom plates. On end studs place additional fasteners 50-60mm vertically and no close than 10mm from plate to stud connections.

Place fasteners at 200mm centres where sheet end butt joints occur.

**Jointing**

All fastener heads stopped and all sheet joints reinforced with paper jointing tape and stopped. All in accordance with EPB® Plasterboard Installation Guide.

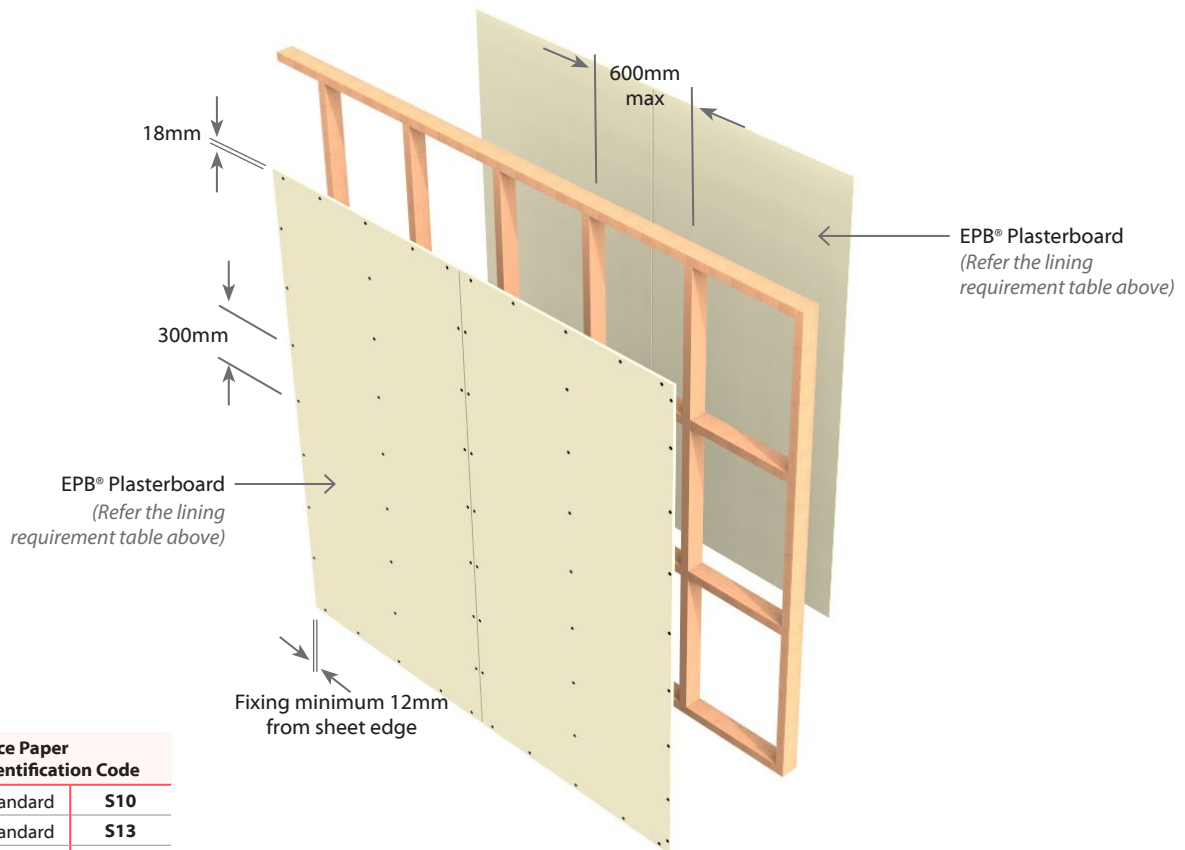

Face Paper Product Identification Code	
10mm EPB® Standard	S10
13mm EPB® Standard	S13
10mm EPB FireSmart®	F10



**E4TL45**

Single Timber Frame

Load Bearing

Two Way FRR

**4** Layers: 2 Layers of Plasterboard to each side of frame

System Number	Lining Suffix	Fire Rating	Load Bearing Ability	Noise Control		Lining Requirement
				STC	Rw	
<b>E4TL45</b>	<b>-S40</b>	45/45/45	LB	42	41	2 x 10mm EPB® Standard on One side 2 x 10mm EPB® Standard to Other side

**Framing**

Framing to comply with relevant sections and clauses of NZBC B1: Structure and NZBC B2: Durability.  
Studs at 600mm centres maximum.  
Nogs at 1200mm centre maximum.

**Wall Height, Load and Framing Dimensions**

These are determined by NZS3604 stud tables for load bearing or non-load bearing partitions.

**Plasterboard Lining**

**NB:** The installer must look for the Product Identification Code on the face paper to ensure the correct board type is installed. Refer to the Face Paper Product Identification Code table on this page.

Two layers of 10mm EPB® Standard lining on each side of the timber framing. Vertical or Horizontal fixing permitted. Use full height or full length sheets where possible.

**For Vertical Fixing-** the vertical sheet joints must be offset on the opposite side of the frame and staggered between layers.

**For Horizontal Fixing-** the horizontal sheet joints on the opposite side of the frame can be formed over the same row of nogs and must be staggered between layers.

Optionally, inner layers can be fixed vertically and outer layers fixed horizontally.

**Sheet end butt joints-** must be formed over framing, offset from opposite side of the frame and staggered between layers.

All sheet joints must be fixed over solid timber framing.  
Sheets shall be touch fitted.

**Fixing of Linings**

**Fasteners**

System Number	Side One		Side Two	
	1 <sup>st</sup> Layer	2 <sup>nd</sup> Layer	1 <sup>st</sup> Layer	2 <sup>nd</sup> Layer
High Thread Drywall Screws				
<b>E4TL45-S40</b>	10mm	10mm	10mm	10mm
	41 x 6g	51 x 7g	41 x 6g	51 x 7g

**Fastener Centres**

**Inner Layer:** Fix 600mm centres at sheet perimeters and on top and bottom plates. Fix at 600mm up each stud.

**Outer Layer:** Fix at 300mm centres at sheet perimeters and on top and bottom plates and 300mm centres up each stud.

Place fasteners no closer than 12mm from the sheet edges and 18mm from sheet ends.

Place fasteners 50mm from sheet corners along the top and bottom plates. On end studs place additional fasteners 50-60mm vertically and no close than 10mm from plate to stud connections.

Place fasteners at 200mm centres where sheet end butt joints occur. Avoid outer layer screws from hitting inner layer screws.

**Jointing**

**Inner Layer:** Unstopped

**Outer Layer:** All fastener heads stopped and all sheet joints reinforced with paper jointing tape and stopped. All in accordance with EPB® Plasterboard Installation Guide.

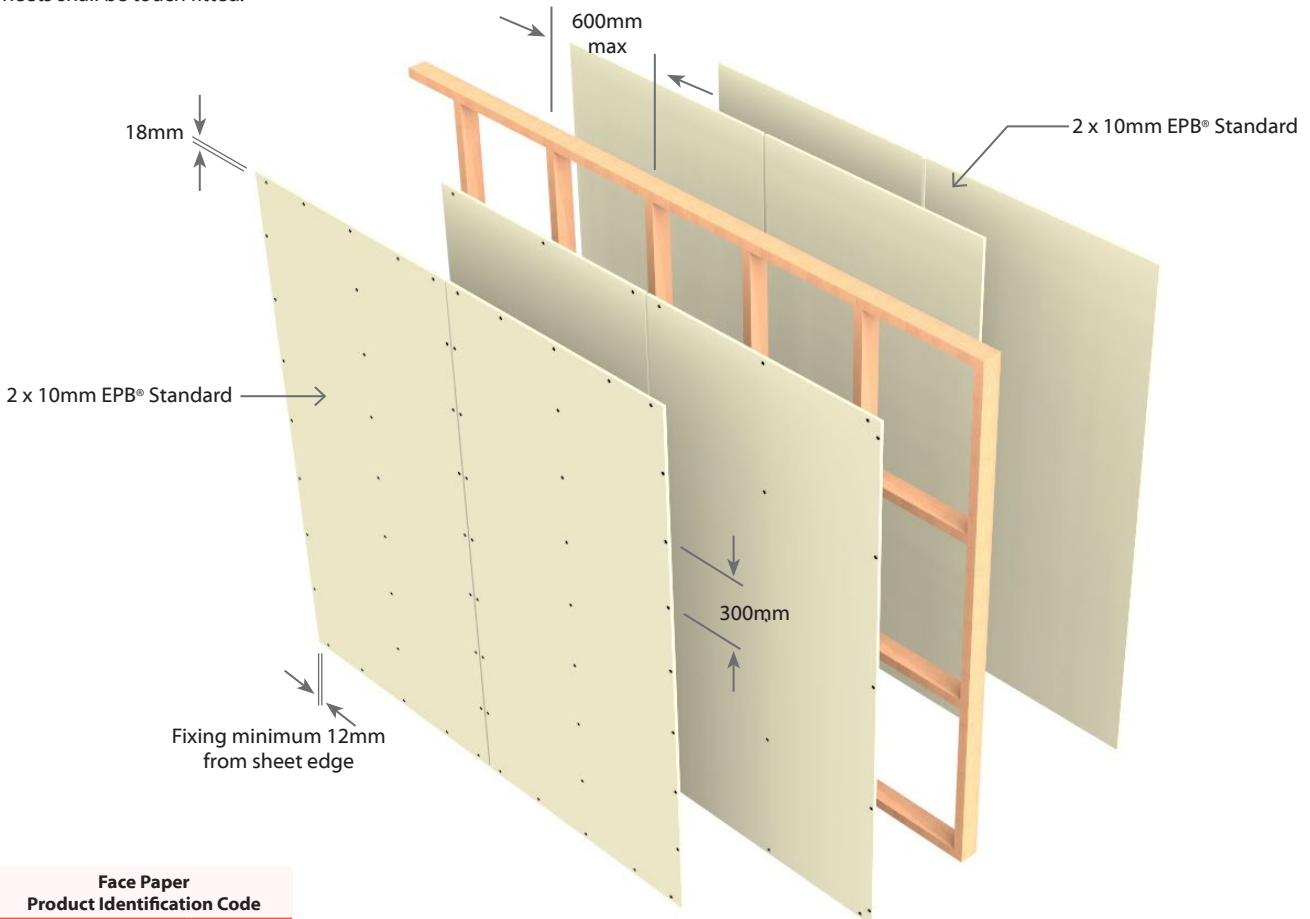

**4 Layers: 2 Layers of Plasterboard to each side of frame**

System Number	Lining Suffix	Fire Rating	Load Bearing Ability	Noise Control		Lining Requirement
				STC	Rw	
<b>E4T60</b>	<b>-S40</b>	-/60/60	NLB	42	41	2 x 10mm EPB® Standard on One side 2 x 10mm EPB® Standard to Other side

**Framing**

Framing to comply with relevant sections and clauses of NZBC B1: Structure and NZBC B2: Durability.  
Studs at 600mm centres maximum.  
Nogs at 1200mm centre maximum.

**Wall Height, Load and Framing Dimensions**

These are determined by NZS3604 stud tables for non-load bearing partitions.

**Plasterboard Lining**

**NB:** The installer must look for the Product Identification Code on the face paper to ensure the correct board type is installed. Refer to the Face Paper Product Identification Code table on this page.

Two layers of 10mm EPB® Standard lining on each side of the timber framing. Vertical or Horizontal fixing permitted. Use full height or full length sheets where possible.

**For Vertical Fixing-** the vertical sheet joints must be offset on the opposite side of the frame and staggered between layers.

**For Horizontal Fixing-** the horizontal sheet joints on the opposite side of the frame can be formed over the same row of nogs and must be staggered between layers.

Optionally, inner layers can be fixed vertically and outer layers fixed horizontally.

**Sheet end butt joints-** must be formed over framing, offset from opposite side of the frame and staggered between layers.

All sheet joints must be fixed over solid timber framing. Sheets shall be touch fitted.

**Fixing of Linings**

**Fasteners**

System Number	Side One		Side Two	
	1 <sup>st</sup> Layer	2 <sup>nd</sup> Layer	1 <sup>st</sup> Layer	2 <sup>nd</sup> Layer
<b>E4T60-S40</b>	High Thread Drywall Screws			
	10mm	10mm	10mm	10mm
	41 x 6g	51 x 7g	41 x 6g	51 x 7g

**Fastener Centres**

**Inner Layer:** Fix 600mm centres vertically up each stud and 600mm horizontally along top and bottom plate.

**Outer Layer:** Fix at 300mm centres at sheet perimeter and 300mm centres on all other studs.

Place fasteners no closer than 12mm from the sheet edges and 18mm from sheet ends.

Place fasteners 50mm from sheet corners along the top and bottom plates. On end studs place additional fasteners 50-60mm vertically and no close than 10mm from plate to stud connections.

Place fasteners at 200mm centres where sheet end butt joints occur. Avoid outer layer screws from hitting inner layer screws.

**Jointing**

**Inner Layer:** Unstopped

**Outer Layer:** All fastener heads stopped and all sheet joints reinforced with paper jointing tape and stopped. All in accordance with EPB Plasterboard Installation Guide.

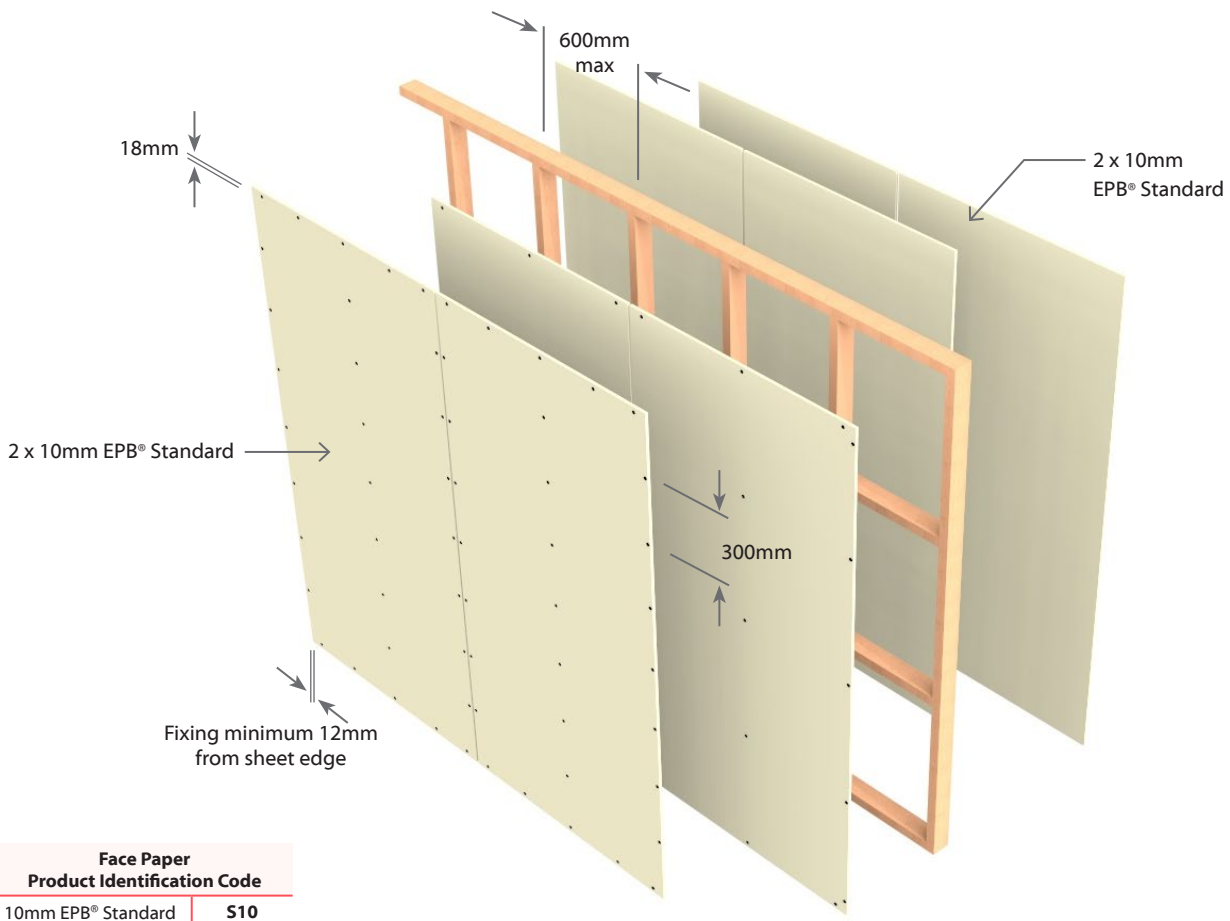

**E2TL60**

Single Timber Frame

Load Bearing

Two Way FRR

**2** Layers: 1 Layers of Plasterboard to each side of frame

System Number	Lining Suffix	Fire Rating	Load Bearing Ability	Noise Control		Lining Requirement
				STC	Rw	
<b>E2TL60</b>	<b>-F26</b>	60/60/60	LB	38	37	1 x 13mm EPB FireSmart® on One side 1 x 13mm EPB FireSmart® to Other side

**Framing**

Framing to comply with relevant sections and clauses of NZBC B1: Structure and NZBC B2: Durability.

Studs at 600mm centres maximum.

Nogs at 1200mm centre maximum.

**Wall Height, Load and Framing Dimensions**

These are determined by NZS3604 stud tables for load bearing or non-load bearing partitions.

**Plasterboard Lining**

**NB:** The installer must look for the Product Identification Code on the face paper to ensure the correct board type is installed. Refer to the Face Paper Product Identification Code table on this page.

One layer of 13mm EPB FireSmart® lining on each side of the timber framing. Vertical or Horizontal fixing permitted. Use full height or full length sheets where possible.

**For Vertical Fixing-** the vertical sheet joints must be offset on the opposite side of the frame.

**For Horizontal Fixing-** the horizontal sheet joints on the opposite side of the frame can be formed over the same row of nogs.

**Sheet end butt joints-** must be formed over framing, offset from opposite side of the frame.

All sheet joints must be fixed over solid timber framing. Sheets shall be touch fitted.

**Fixing of Linings**

**Fasteners**

System Number	Side One	Side Two
	High Thread Drywall Screws	
<b>E2TL60-F26</b>	13mm	13mm
	41 x 6g	41 x 6g

**Fastener Centres**

Fix at 300mm centres at sheet perimeters and on top and bottom plates. And 300mm centres up all studs.

Place fasteners 50mm from sheet corners along the top and bottom plates. On end studs place additional fasteners 50-60mm vertically and no closer than 10mm from plate to stud connections.

Place fasteners no closer than 12mm from the sheet edges and 18mm from sheet ends.

Place fasteners at 200mm centres where sheet end butt joints occur.

**Jointing**

All fastener heads stopped and all sheet joints reinforced with paper jointing tape and stopped. All in accordance with EPB® Plasterboard Installation Guide.

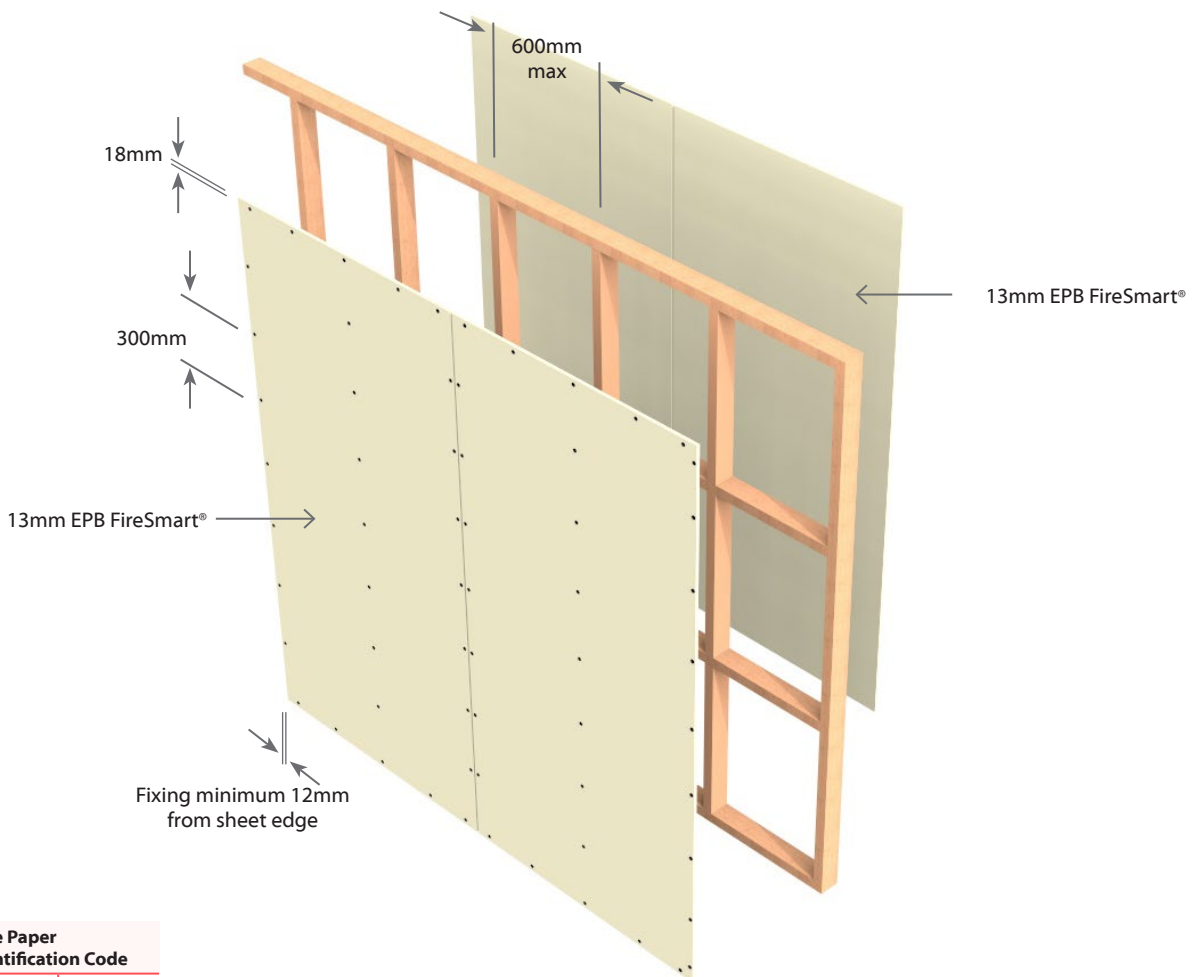

**4 Layers:** 2 Layers of Plasterboard to each side of frame

System Number	Lining Suffix	Fire Rating	Load Bearing Ability	Noise Control		Lining Requirement
				STC	Rw	
<b>E4TL60</b>	<b>-F40</b>	60/60/60	LB	42	41	2 x 10mm EPB FireSmart® on One side 2 x 10mm EPB FireSmart® to Other side
	<b>-S46</b>	60/60/60	LB	42	41	1 x 10mm and 1 x 13mm EPB® Standard on One side 1 x 10mm and 1 x 13mm EPB® Standard on Other side
	<b>-MS40</b>	60/60/60	LB	42	41	1 x 10mm EPB® Standard and 1 x 10mm EPB MultiSmart® on One side 1 x 10mm EPB® Standard and 1 x 10mm EPB MultiSmart® on Other side
	<b>-S52</b>	60/60/60	LB	43	42	2 x 13mm EPB® Standard on One side 2 x 13mm EPB® Standard to Other side

**Framing**

Framing to comply with relevant sections and clauses of NZBC B1: Structure and NZBC B2: Durability.  
Studs at 600mm centres maximum.  
Nogs at 1200mm centre maximum.

**Wall Height, Load and Framing Dimensions**

These are determined by NZS3604 stud tables for load bearing or non-load bearing partitions.

**Plasterboard Lining**

**NB:** The installer must look for the Product Identification Code on the face paper to ensure the correct board type is installed. Refer to the Face Paper Product Identification Code table on this page.

Two layers of EPB® Plasterboard lining as per specified system above on each side of the timber framing. Vertical or Horizontal fixing permitted. Use full height or full length sheets where possible.

**For Vertical Fixing-** the vertical sheet joints must be offset on the opposite side of the frame and staggered between layers.

**For Horizontal Fixing-** the horizontal sheet joints on the opposite side of the frame can be formed over the same row of nogs and must be staggered between layers.

Optionally, inner layers can be fixed vertically and outer layers fixed horizontally.

**Sheet end butt joints-** must be formed over framing, offset from opposite side of the frame and staggered between layers.

All sheet joints must be fixed over solid timber framing. Sheets shall be touch fitted.

**Fixing of Linings**

**Fasteners (As per Specified System Above)**

System Number	Side One		Side Two	
	1 <sup>st</sup> Layer	2 <sup>nd</sup> Layer	1 <sup>st</sup> Layer	2 <sup>nd</sup> Layer
	High Thread Drywall Screws			
<b>E4TL60-F40</b>	10mm	10mm	10mm	10mm
<b>E4TL60-MS40</b>	41 x 6g	51 x 7g	41 x 6g	51 x 7g
<b>E4TL60-S46</b>	10mm	13mm	10mm	13mm
	41 x 6g	51 x 7g	41 x 6g	51 x 7g
<b>E4TL60-S52</b>	13mm	13mm	13mm	13mm
	41 x 6g	51 x 7g	41 x 6g	51 x 7g

**Fastener Centres**

**Inner Layer:** Fix 600mm centres at sheet perimeters and on top and bottom plates. Fix at 600mm up each stud

**Outer Layer:** Fix at 300mm centres at sheet perimeters and on top and bottom plates and 300mm centres up each stud.

Place fasteners 50mm from sheet corners along the top and bottom plates. On end studs place additional fasteners 50-60mm vertically and no closer than 10mm from plate to stud connections.

Place fasteners no closer than 12mm from the sheet edges and 18mm from sheet ends.

Place fasteners at 200mm centres where sheet end butt joints occur.

Avoid outer layer screws from hitting inner layer screws.

**Jointing**

**Inner Layer:** Unstopped

**Outer Layer:** All fastener heads stopped and all sheet joints reinforced with paper jointing tape and stopped. All in accordance with EPB® Plasterboard Installation Guide.

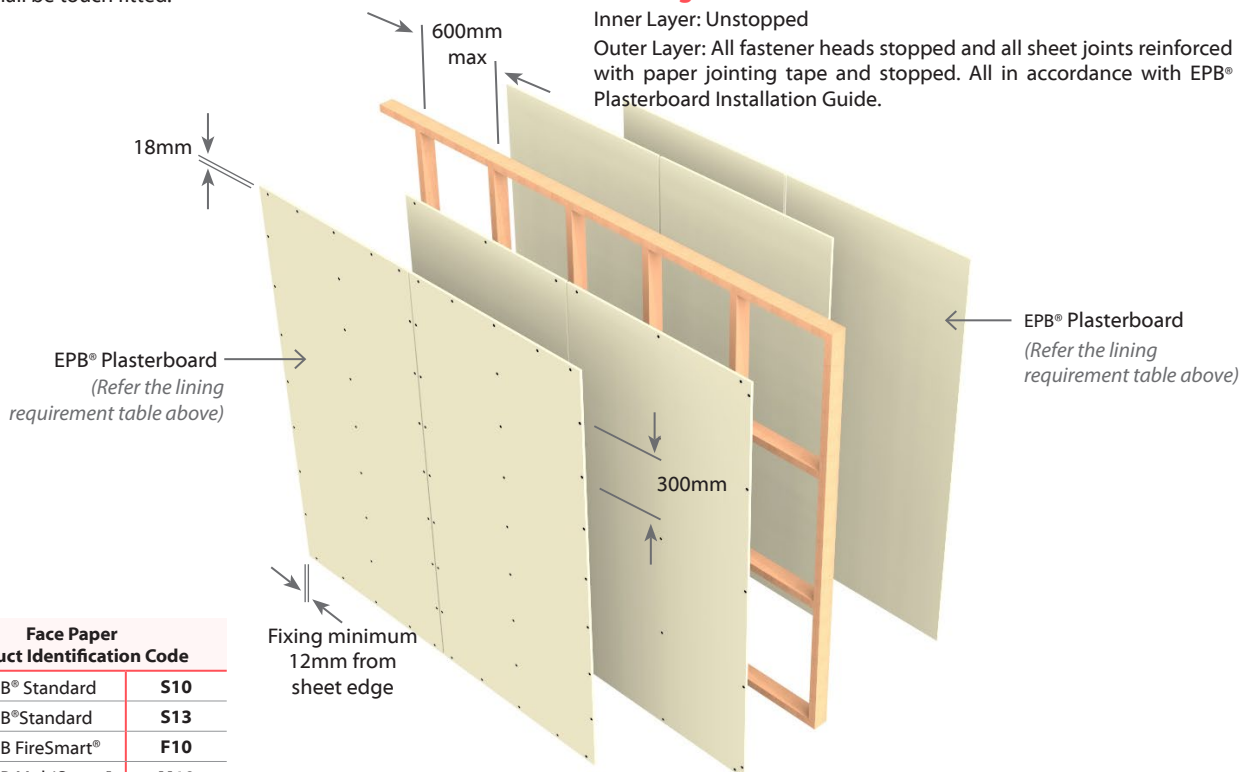

2 Layers: 1 Layer of Plasterboard to each side of frame

System Number	Lining Suffix	Fire Rating	Load Bearing Ability	Noise Control		Lining Requirement
				STC	Rw	
E2TL75	-F32	75/75/75	LB	38	37	1 x 16mm EPB FireSmart® on One side 1 x 16mm EPB FireSmart® to Other side

**Framing**

Framing to comply with relevant sections and clauses of NZBC B1: Structure and NZBC B2: Durability.  
Studs at 600mm centres maximum.  
Nogs at 1200mm centre maximum.

**Wall Height, Load and Framing Dimensions**

These are determined by NZS3604 stud tables for load bearing or non-load bearing partitions.

**Plasterboard Lining**

**NB:** The installer must look for the Product Identification Code on the face paper to ensure the correct board type is installed. Refer to the Face Paper Product Identification Code table on this page.

One layer of 16mm EPB FireSmart® lining on each side of the timber framing. Vertical or Horizontal fixing permitted. Use full height or full length sheets where possible.

**For Vertical Fixing-** the vertical sheet joints must be offset on the opposite side of the frame.

**For Horizontal Fixing-** the horizontal sheet joints on the opposite side of the frame can be formed over the same row of nogs.

**Sheet end butt joints-** must be formed over framing, offset from opposite side of the frame.

All sheet joints must be fixed over solid timber framing.

Sheets shall be touch fitted.

**Fixing of Linings**

**Fasteners**

System Number	Side One	Side Two
	High Thread Drywall Screws	
E2TL75-F32	16mm	16mm
	51 x 7g	51 x 7g

**Fastener Centres**

Fix at 300mm centres around sheet perimeter and up all intermediate studs.

Place fasteners 50mm from sheet corners along the top and bottom plates. On end studs place additional fasteners 50-60mm vertically and no close than 10mm from plate to stud connections.

Place fasteners no closer than 12mm from the sheet edges and 18mm from sheet ends.

Place fasteners at 200mm centres where sheet end butt joints occur.

**Jointing**

All fastener heads stopped and all sheet joints reinforced with paper jointing tape and stopped. All in accordance with EPB® Plasterboard Installation Guide.

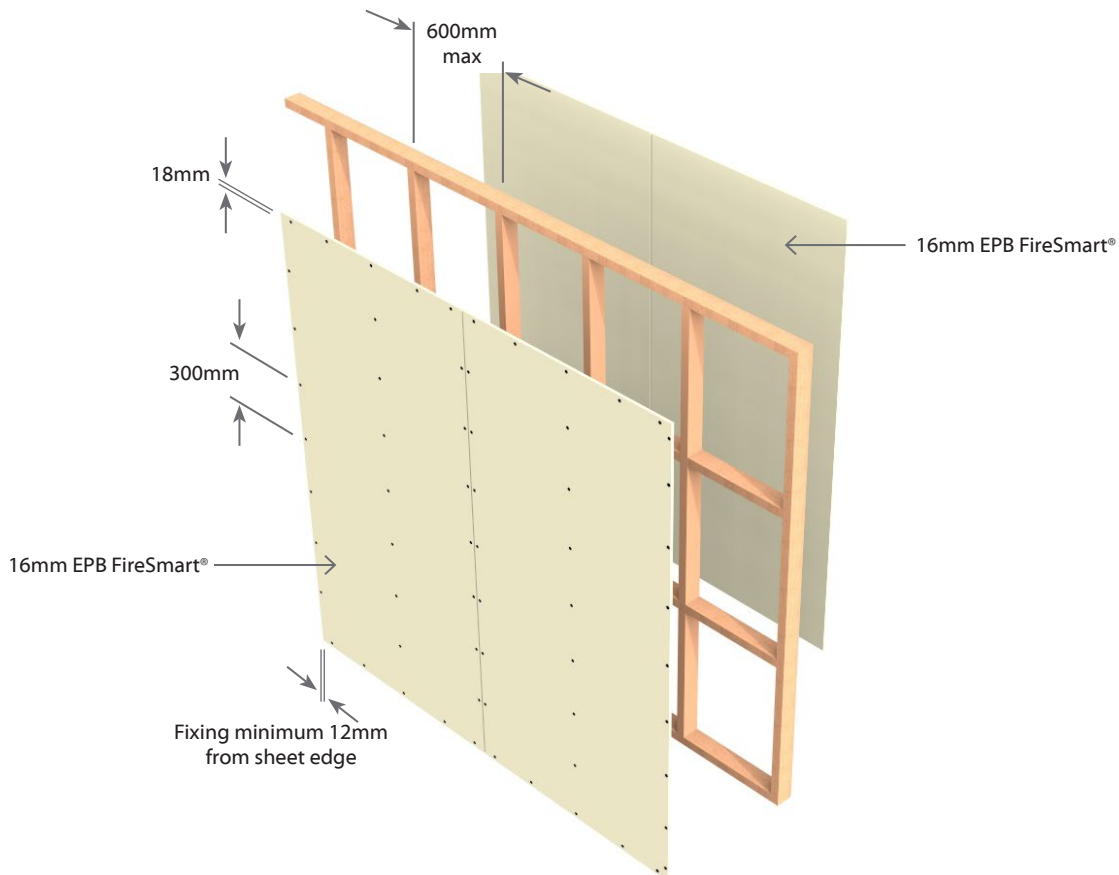

Face Paper Product Identification Code	
16mm EPB FireSmart®	F16



**4 Layers: 2 Layers of Plasterboard to each side of frame**

System Number	Lining Suffix	Fire Rating	Load Bearing Ability	Noise Control		Lining Requirement
				STC	Rw	
<b>E4T90</b>	<b>-FS52</b>	-/90/90	NLB	43	42	1 x 13mm EPB FireSmart® and 1 x 13mm EPB® Standard on One side 1 x 13mm EPB FireSmart® and 1 x 13mm EPB® Standard to Other side
	<b>-FM46</b>	-/90/90	NLB	43	42	1 x 13mm EPB FireSmart® and 1 x 10mm EPB MultiSmart® on One side 1 x 13mm EPB FireSmart® and 1 x 10mm EPB MultiSmart® to Other side

**Framing**

Framing to comply with relevant sections and clauses of NZBC B1: Structure and NZBC B2: Durability.  
Studs at 600mm centres maximum.  
Nogs at 1200mm centre maximum.

**Wall Height, Load and Framing Dimensions**

These are determined by NZS3604 stud tables for non-load bearing partitions.

**Plasterboard Lining**

**NB:** The installer must look for the Product Identification Code on the face paper to ensure the correct board type is installed. Refer to the Face Paper Product Identification Code table on this page.

Two layers of EPB® Plasterboard lining as per specified system above on each side of the timber framing.

Vertical or Horizontal fixing permitted. Use full height or full length sheets where possible.

**For Vertical Fixing-** the vertical sheet joints must be offset on the opposite side of the frame and staggered between layers.

**For Horizontal Fixing-** the horizontal sheet joints on the opposite side of the frame can be formed over the same row of nogs and must be staggered between layers.

Optionally, inner layers can be fixed vertically and outer layers fixed horizontally.

**Sheet end butt joints-** must be formed over framing, offset from opposite side of the frame and staggered between layers.

All sheet joints must be fixed over solid timber framing.  
Sheets shall be touch fitted.

**Fixing of Linings**

**Fasteners**

System Number	Side One		Side Two	
	1 <sup>st</sup> Layer	2 <sup>nd</sup> Layer	1 <sup>st</sup> Layer	2 <sup>nd</sup> Layer
	High Thread Drywall Screws			
<b>E4T90-FS52</b>	13mm	13mm	13mm	13mm
	41 x 6g	51 x 7g	41 x 6g	51 x 7g
<b>E4T90-FM46</b>	13mm	10mm	13mm	10mm
	41 x 6g	51 x 7g	41 x 6g	51 x 7g

**Fastener Centres**

Inner Layer: Fix 600mm centres vertically up each stud and 600mm horizontally along top and bottom plate.

Outer Layer: Fix at 300mm centres at sheet perimeter and 300mm centres on all other studs.

Place fasteners 50mm from sheet corners along the top and bottom plates. On end studs place additional fasteners 50-60mm vertically and no closer than 10mm from plate to stud connections.

Place fasteners no closer than 12mm from the sheet edges and 18mm from sheet ends.

Place fasteners at 200mm centres where sheet end butt joints occur. Avoid outer layer screws from hitting inner layer screws.

**Jointing**

Inner Layer: Unstopped

Outer Layer: All fastener heads stopped and all sheet joints reinforced with paper jointing tape and stopped. All in accordance with EPB® Plasterboard Installation Guide.

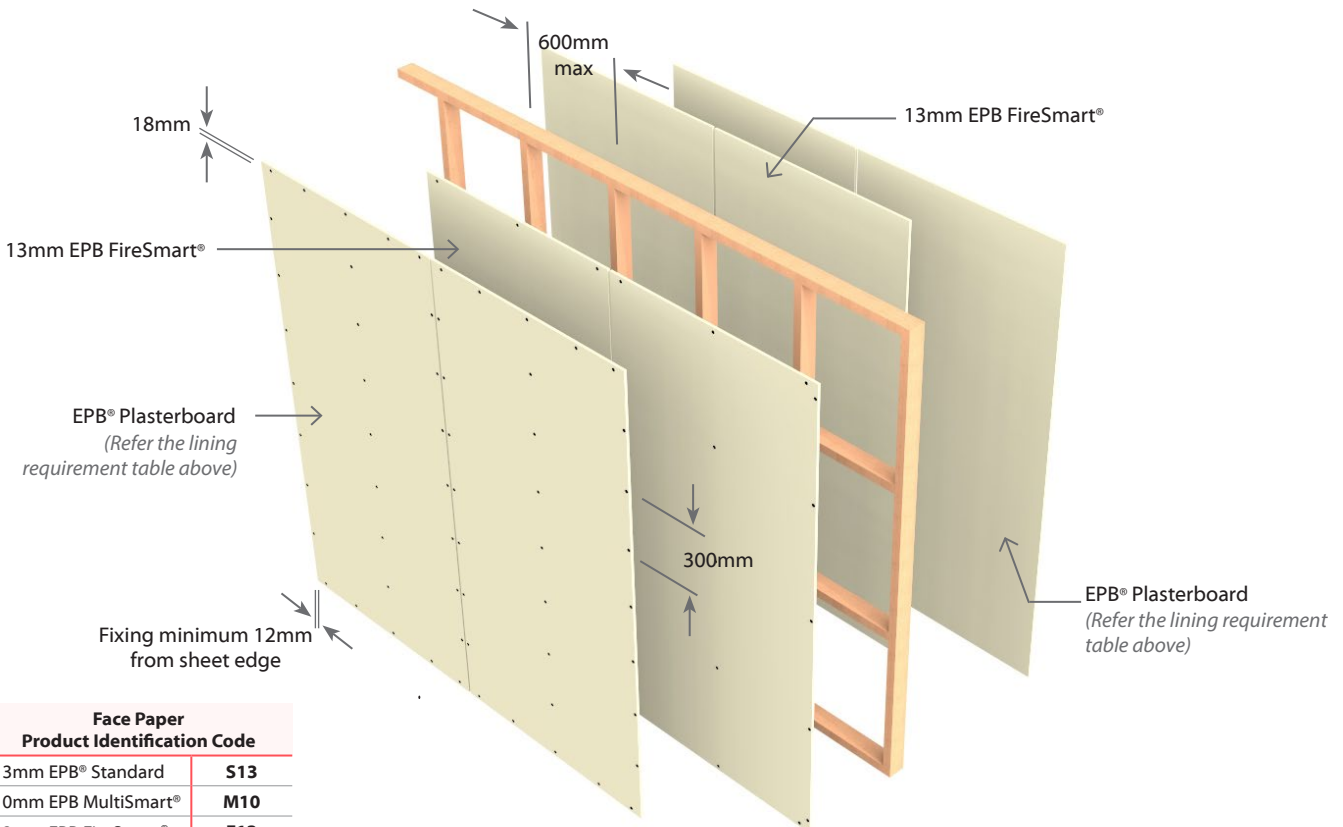

**E4TL90**

Single Timber Frame

Load Bearing

Two Way FRR

**4** Layers: 2 Layers of Plasterboard to each side of frame

System Number	Lining Suffix	Fire Rating	Load Bearing Ability	Noise Control		Lining Requirement
				STC	Rw	
<b>E4TL90</b>	<b>-F52</b>	90/90/90	LB	45	44	2 x 13mm EPB FireSmart® on One side 2 x 13mm EPB FireSmart® to Other side

**Framing**

Framing to comply with relevant sections and clauses of NZBC B1: Structure and NZBC B2: Durability.  
Studs at 600mm centres maximum.  
Nogs at 1200mm centre maximum.

**Wall Height, Load and Framing Dimensions**

These are determined by NZS3604 stud tables for load bearing or non-load bearing partitions.

**Plasterboard Lining**

**NB:** The installer must look for the Product Identification Code on the face paper to ensure the correct board type is installed. Refer to the Face Paper Product Identification Code table on this page.

Two layers of 13mm EPB FireSmart® lining on each side of the timber framing. Vertical or Horizontal fixing permitted. Use full height or full length sheets where possible.

**For Vertical Fixing-** the vertical sheet joints must be offset on the opposite side of the frame and staggered between layers.

**For Horizontal Fixing-** the horizontal sheet joints on the opposite side of the frame can be formed over the same row of nogs and must be staggered between layers.

Optionally, inner layers can be fixed vertically and outer layers fixed horizontally.

**Sheet end butt joints-** must be formed over framing, offset from opposite side of the frame and staggered between layers.

All sheet joints must be fixed over solid timber framing. Sheets shall be touch fitted.

**Fixing of Linings**

**Fasteners**

System Number	Side One		Side Two	
	1 <sup>st</sup> Layer	2 <sup>nd</sup> Layer	1 <sup>st</sup> Layer	2 <sup>nd</sup> Layer
<b>E4TL90-F52</b>	High Thread Drywall Screws			
	13mm 41 x 6g	13mm 51 x 7g	13mm 41 x 6g	13mm 51 x 7g

**Fastener Centres**

**Inner Layer:** Fix 600mm centres at sheet perimeters and on top and bottom plates. Fix at 600mm up each stud.

**Outer Layer:** Fix at 300mm centres at sheet perimeters and on top and bottom plates and 300mm centres up each stud.

Place fasteners 50mm from sheet corners along the top and bottom plates. On end studs place additional fasteners 50-60mm vertically and no close than 10mm from plate to stud connections.

Place fasteners no closer than 12mm from the sheet edges and 18mm from sheet ends.

Place fasteners at 200mm centres where sheet end butt joints occur.

Avoid outer layer screws from hitting inner layer screws.

**Jointing**

**Inner Layer:** Unstopped

**Outer Layer:** All fastener heads stopped and all sheet joints reinforced with paper jointing tape and stopped. All in accordance with EPB® Plasterboard Installation Guide.

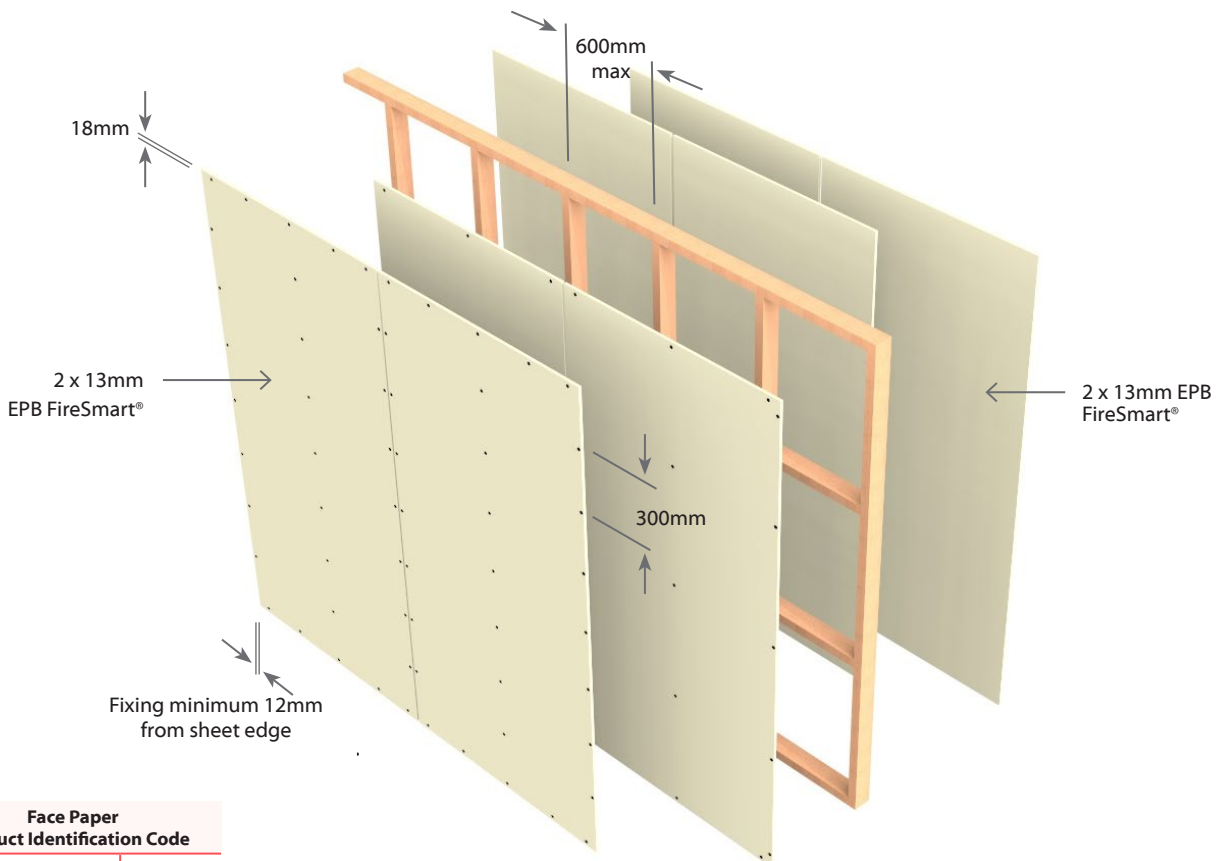

**4** Layers: 2 Layers of Plasterboard to each side of frame

System Number	Lining Suffix	Fire Rating	Load Bearing Ability	Noise Control		Lining Requirement
				STC	Rw	
<b>E4T105</b>	<b>-F52</b>	-/105/105	NLB	44	43	2 x 13mm EPB FireSmart® on One side 2 x 13mm EPB FireSmart® to Other side

**Framing**

Framing to comply with relevant sections and clauses of NZBC B1: Structure and NZBC B2: Durability.  
Studs at 600mm centres maximum.  
Nogs at 1200mm centre maximum.

**Wall Height, Load and Framing Dimensions**

These are determined by NZS3604 stud tables for load bearing or non-load bearing partitions.

**Plasterboard Lining**

**NB:** The installer must look for the Product Identification Code on the face paper to ensure the correct board type is installed. Refer to the Face Paper Product Identification Code table on this page.

Two layers of 13mm EPB FireSmart® lining on each side of the timber framing. Vertical or Horizontal fixing permitted. Use full height or full length sheets where possible.

**For Vertical Fixing-** the vertical sheet joints must be offset on the opposite side of the frame and staggered between layers.

**For Horizontal Fixing-** the horizontal sheet joints on the opposite side of the frame can be formed over the same row of nogs and must be staggered between layers.

Optionally, inner layers can be fixed vertically and outer layers fixed horizontally.

**Sheet end butt joints-** must be formed over framing, offset from opposite side of the frame and staggered between layers.

All sheet joints must be fixed over solid timber framing.  
Sheets shall be touch fitted.

**Fixing of Linings**

**Fasteners**

System Number	Side One		Side Two	
	1 <sup>st</sup> Layer	2 <sup>nd</sup> Layer	1 <sup>st</sup> Layer	2 <sup>nd</sup> Layer
	High Thread Drywall Screws			
<b>E4T105-F52</b>	13mm	13mm	13mm	13mm
	41 x 6g	51 x 7g	41 x 6g	51 x 7g

**Fastener Centres**

**Inner Layer:** Fix 600mm centres at sheet perimeters and on top and bottom plates. Fix at 600mm up each stud.

**Outer Layer:** Fix at 300mm centres at sheet perimeters and on top and bottom plates and 300mm centres up each stud.

Place fasteners 50mm from sheet corners along the top and bottom plates. On end studs place additional fasteners 50-60mm vertically and no close than 10mm from plate to stud connections.

Place fasteners no closer than 12mm from the sheet edges and 18mm from sheet ends.

Place fasteners at 200mm centres where sheet end butt joints occur.

Avoid outer layer screws from hitting inner layer screws.

**Jointing**

**Inner Layer:** Unstopped

**Outer Layer:** All fastener heads stopped and all sheet joints reinforced with paper jointing tape and stopped. All in accordance with EPB® Plasterboard Installation Guide.

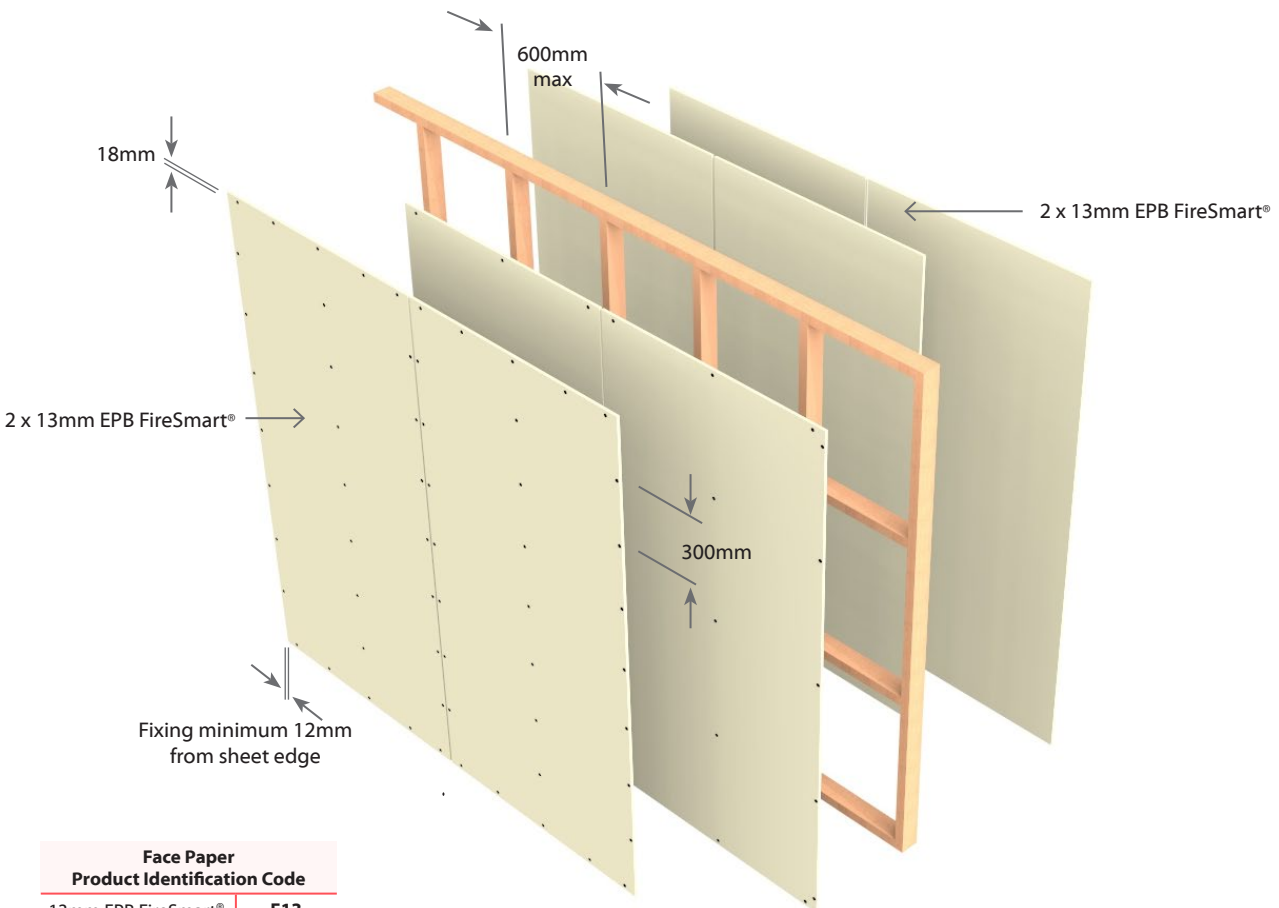

**4 Layers:** 2 Layers of Plasterboard to each side of frame

System Number	Lining Suffix	Fire Rating	Load Bearing Ability	Noise Control		Lining Requirement
				STC	Rw	
<b>E4T120</b>	<b>-F58</b>	-/120/120	NLB	46	45	1 x 16mm EPB FireSmart® and 1 x 13mm EPB FireSmart® on One side 1 x 16mm EPB FireSmart® and 1 x 13mm EPB FireSmart® to Other side

**Framing**

Framing to comply with relevant sections and clauses of NZBC B1: Structure and NZBC B2: Durability.  
Studs at 600mm centres maximum.  
Nogs at 800mm centre maximum.

**Wall Height, Load and Framing Dimensions**

These are determined by NZS3604 stud tables for non-load bearing partitions.

**Plasterboard Lining**

**NB:** The installer must look for the Product Identification Code on the face paper to ensure the correct board type is installed. Refer to the Face Paper Product Identification Code table on this page.

One layer of 16mm EPB FireSmart® & One layer of 13mm EPB FireSmart® lining on each side of the timber framing.

Vertical fixing only permitted. Use full height sheets where possible.

**Vertical Fixing-** the vertical sheet joints must be offset on the opposite side of the frame and staggered between layers.

**Sheet end butt joints-** must be formed over framing, offset from opposite side of the frame and staggered between layers.

All sheet joints must be fixed over solid timber framing. Sheets shall be touch fitted.

**Fixing of Linings**

**Fasteners**

System Number	Side One		Side Two	
	1 <sup>st</sup> Layer	2 <sup>nd</sup> Layer	1 <sup>st</sup> Layer	2 <sup>nd</sup> Layer
<b>E4T120-F58</b>	High Thread Drywall Screws			
	16mm	13mm	16mm	13mm
	41 x 6g	51 x 7g	41 x 6g	51 x 7g

**Fastener Centres**

**Inner Layer:** Fix 600mm centres vertically up each stud and 600mm horizontally along top and bottom plate.

**Outer Layer:** Fix at 300mm centres at sheet perimeter and 300mm centres on all other studs.

Place fasteners 50mm from sheet corners along the top and bottom plates. On end studs place additional fasteners 50-60mm vertically and no close than 10mm from plate to stud connections.

Place fasteners no closer than 12mm from the sheet edges and 18mm from sheet ends.

Place fasteners at 200mm centres where sheet end butt joints occur. Avoid outer layer screws from hitting inner layer screws.

**Jointing**

**Inner Layer:** Unstopped

**Outer Layer:** All fastener heads stopped and all sheet joints reinforced with paper jointing tape and stopped. All in accordance with EPB® Plasterboard Installation Guide.

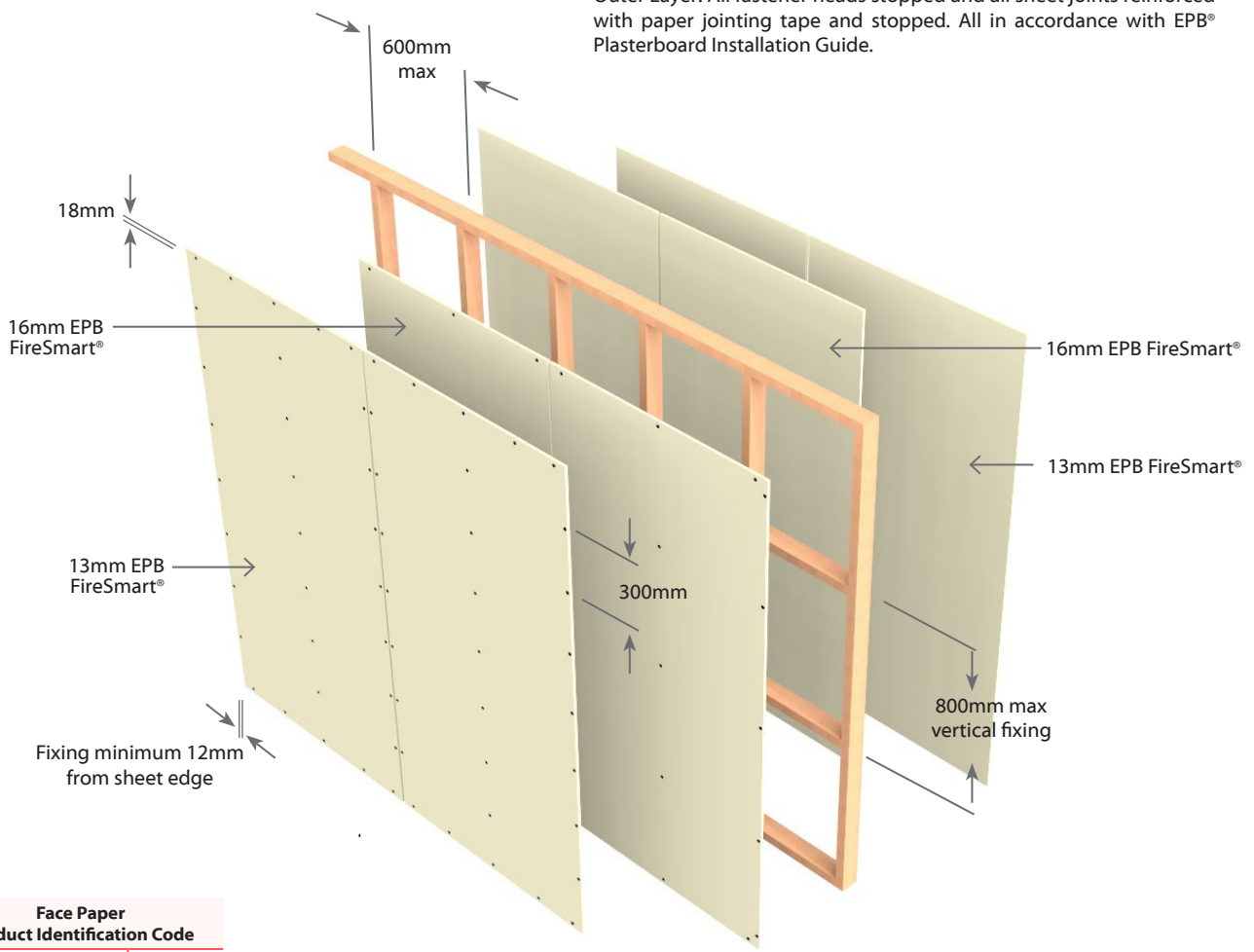

Face Paper Product Identification Code	
13mm EPB FireSmart®	<b>F13</b>
16mm EPB FireSmart®	<b>F16</b>



**6** Layers: 3 Layers of Plasterboard to each side of frame

System Number	Lining Suffix	Fire Rating	Load Bearing Ability	Noise Control		Lining Requirement
				STC	Rw	
<b>E6TL120</b>	<b>-F78</b>	120/120/120	LB	44	43	3 x 13mm EPB FireSmart® on One side 3 x 13mm EPB FireSmart® to Other side

**Framing**

Framing to comply with relevant sections and clauses of NZBC B1: Structure and NZBC B2: Durability.  
Studs at 600mm centres maximum.  
Nogs at 800mm centre maximum.

**Wall Height, Load and Framing Dimensions**

These are determined by NZS3604 stud tables for load bearing or non-load bearing partitions.

**Plasterboard Lining**

**NB:** The installer must look for the Product Identification Code on the face paper to ensure the correct board type is installed. Refer to the Face Paper Product Identification Code table on this page.

Three layers of 13mm EPB FireSmart® lining on each side of the timber framing.

Vertical fixing only permitted. Use full height sheets where possible.

**Vertical Fixing**- the vertical sheet joints must be offset on the opposite side of the frame and staggered between layers.

**Sheet end butt joints**- must be formed over framing, offset from opposite side of the frame and staggered between layers.

All sheet joints must be fixed over solid timber framing.  
Sheets shall be touch fitted.

**Fixing of Linings**

**Fasteners**

System Number	1 <sup>st</sup> Layer	2 <sup>nd</sup> Layer	3 <sup>rd</sup> Layer
		High Thread Drywall Screws	
<b>E6TL120-F78</b>	13mm	13mm	13mm
	41 x 6g	51 x 7g	63 x 8g

**Fastener Centres**

1st and 2nd Layer: Fix 600mm centres at sheet perimeters and on top and bottom plates. Fix at 600mm up each stud

3rd Layer: Fix at 300mm centres at sheet perimeters and on top and bottom plates and 300mm centres up each stud.

Place fasteners 50mm from sheet corners along the top and bottom plates. On end studs place additional fasteners 50-60mm vertically and no close than 10mm from plate to stud connections.

Place fasteners no closer than 12mm from the sheet edges and 18mm from sheet ends.

Place fasteners at 200mm centres where sheet end butt joints occur. Avoid outer layer screws from hitting inner layer screws.

**Jointing**

1st and 2nd Layer: Unstopped

3rd Layer: All fastener heads stopped and all sheet joints reinforced with paper jointing tape and stopped. All in accordance with EPB® Plasterboard Installation Guide.

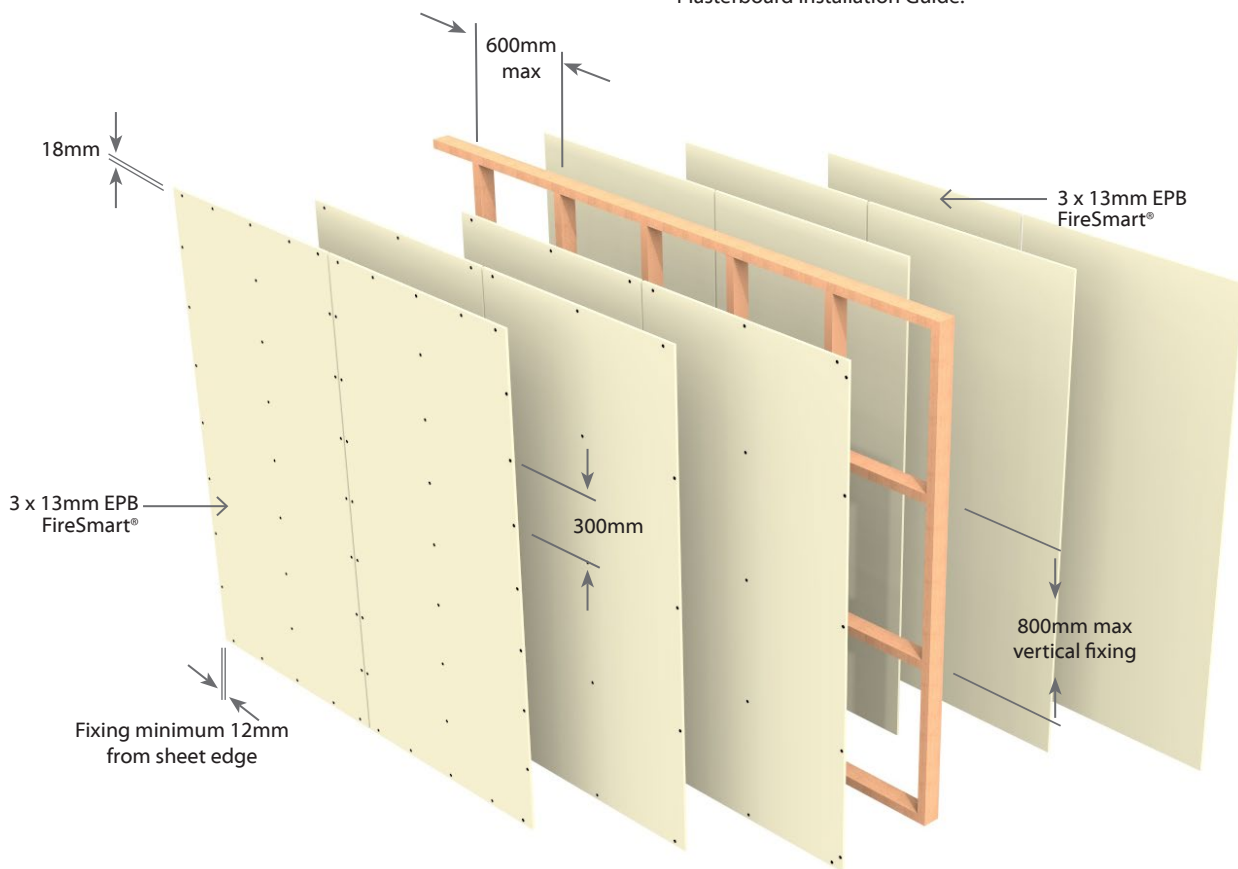

Face Paper Product Identification Code	
13mm EPB FireSmart®	<b>F13</b>



**EBV1TL30** Single Timber Frame with Brick Veneer Load Bearing | Two Way FRR

**1** Layer: 1 Layer of Plasterboard to one side of frame & Brick Veneer to the other side of the frame

System Number	Lining Suffix	Fire Rating	Load Bearing Ability	Noise Control		Lining Requirement
				STC	Rw	
EBV1TL30	-F10	30/30/30	LB	46	45	1 x 10mm EPB FireSmart® on One side Brick Veneer to Other side
EBV1TL30	-S13	30/30/30	LB	46	45	1 x 13mm EPB® Standard on One side Brick Veneer to Other side

**Framing**

Framing to comply with relevant sections and clauses of NZBC B1: Structure and NZBC B2: Durability.  
Studs at 600mm centres maximum.  
Nogs at 1200mm centre maximum.

**Wall Height, Load and Framing Dimensions**

These are determined by NZS3604 stud tables for load bearing or non-load bearing partitions.  
Minimum stud dimension 90 x 35mm  
Maximum stud height not exceeding 3.0m.  
For higher stud heights consult brick manufacturers.

**Brick Veneer**

Brick veneer must comply to AS/NZS 4456 and AS/NZS 4455 with minimum thickness of 70mm. Brick Manufacturer must demonstrate minimum 60 minutes fire resistance.  
Brick veneer cladding installed as per manufacturer's technical specification and relevant NZ Standards.

**Cavity Insulation**

Fill wall cavity between studs and nogs with 1 layer of 90mm thick R2.2 glass wool insulation.

**Plasterboard Lining**

**NB:** The installer must look for the Product Identification Code on the face paper to ensure the correct board type is installed. Refer to the Face Paper Product Identification Code table on this page.

One layer of EPB® Plasterboard lining as per specified system above on one side of the timber framing.

Vertical or Horizontal fixing permitted. Use full height or full length sheets where possible.

**Sheet end butt joints-** must be formed over framing. All sheet joints must be fixed over solid timber framing. Sheets shall be touch fitted.

**Fixing of Linings**

**Fasteners (As per Specified System Above)**

System Number	Single Layer
	High Thread Drywall Screws
EBV1TL30-F10	10mm
	41 x 6g
EBV1TL30-S13	13mm
	41 x 6g

**Fastener Centres**

Fix at 300mm centres at sheet perimeters, on top and bottom plates and 300mm centres up all studs.

Place fasteners no closer than 12mm from the sheet edges and 18mm from sheet ends.

Place fasteners 50mm from sheet corners along the top and bottom plates. On end studs place additional fasteners 50-60mm vertically and no close than 10mm from plate to stud connections.

Place fasteners at 200mm centres where sheet end butt joints occur.

**Jointing**

All fastener heads stopped and all sheet joints reinforced with paper jointing tape and stopped. All in accordance with EPB® Plasterboard Installation Guide.

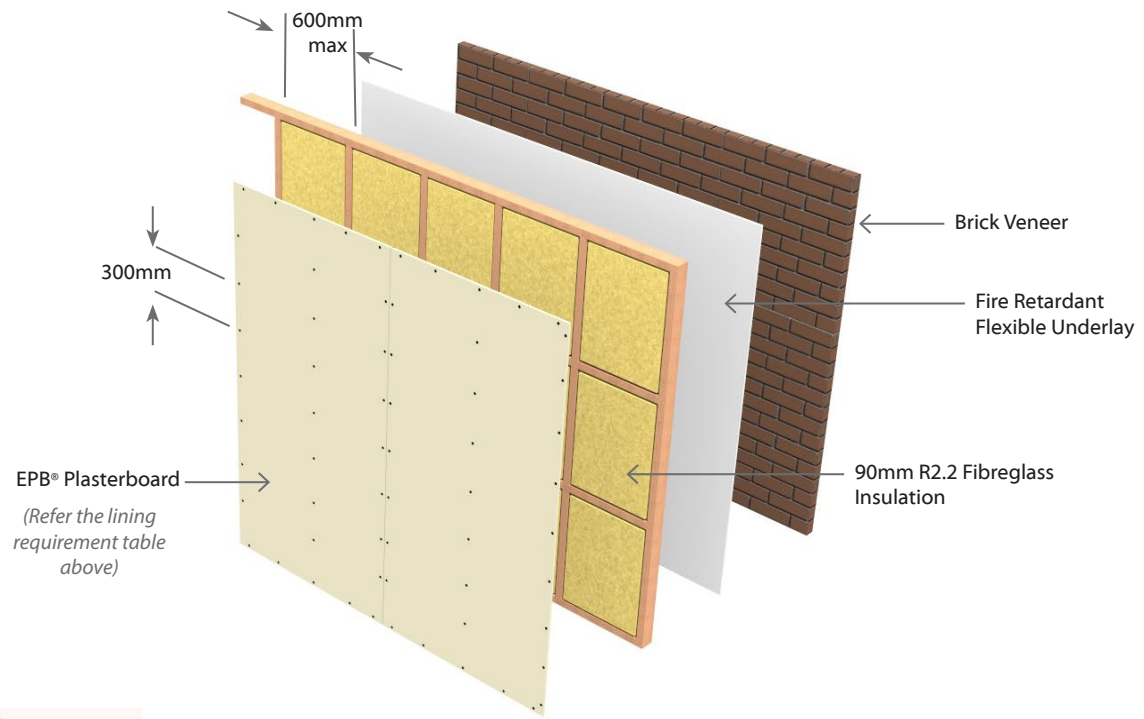

Face Paper Product Identification Code	
13mm EPB® Standard	<b>S13</b>
10mm EPB FireSmart®	<b>F10</b>

**EBV1TL60** Single Timber Frame with Brick Veneer Load Bearing | Two Way FRR

**1** Layer: 1 Layer of Plasterboard to one side of frame & Brick Veneer to the other side of the frame

System Number	Lining Suffix	Fire Rating	Load Bearing Ability	Noise Control		Lining Requirement
				STC	Rw	
<b>EBV1TL60</b>	<b>-F13</b>	60/60/60	LB	46	45	1 x 13mm EPB FireSmart® on One side Brick Veneer to Other side

**Framing**

Framing to comply with relevant sections and clauses of NZBC B1: Structure and NZBC B2: Durability.  
Studs at 600mm centres maximum.  
Nogs at 1200mm centre maximum.

**Wall Height, Load and Framing Dimensions**

These are determined by NZS3604 stud tables for load bearing or non-load bearing partitions.  
Minimum stud dimension 90 x 35mm  
Maximum stud height not exceeding 3.0m.  
For higher stud heights consult brick manufacturers.

**Brick Veneer**

Brick veneer must comply to AS/NZS 4456 and AS/NZS 4455 with minimum thickness of 70mm. Brick Manufacturer must demonstrate minimum 60 minutes fire resistance.  
Brick veneer cladding installed as per manufacturer's technical specification and relevant NZ Standards.

**Cavity Insulation**

Fill wall cavity between studs and nogs with 1 layer of 90mm thick R2.2 glass wool insulation.

**Plasterboard Lining**

**NB:** The installer must look for the Product Identification Code on the face paper to ensure the correct board type is installed. Refer to the Face Paper Product Identification Code table on this page.

One layer of 13mm EPB FireSmart® lining on one side of the timber framing.  
Vertical or Horizontal fixing permitted. Use full height or full length sheets where possible.

**Sheet end butt joints-** must be formed over framing. All sheet joints must be fixed over solid timber framing. Sheets shall be touch fitted.

**Fixing of Linings**

**Fasteners**

System Number	Single Layer
	High Thread Drywall Screws
<b>EBV1TL60-F13</b>	13mm 41 x 6g

**Fastener Centres**

Fix at 300mm centres at sheet perimeters, on top and bottom plates and 300mm centres up all studs.  
Place fasteners no closer than 12mm from the sheet edges and 18mm from sheet ends.  
Place fasteners 50mm from sheet corners along the top and bottom plates. On end studs place additional fasteners 50-60mm vertically and no close than 10mm from plate to stud connections.  
Place fasteners at 200mm centres where sheet end butt joints occur.

**Jointing**

All fastener heads stopped and all sheet joints reinforced with paper jointing tape and stopped. All in accordance with EPB® Plasterboard Installation Guide.

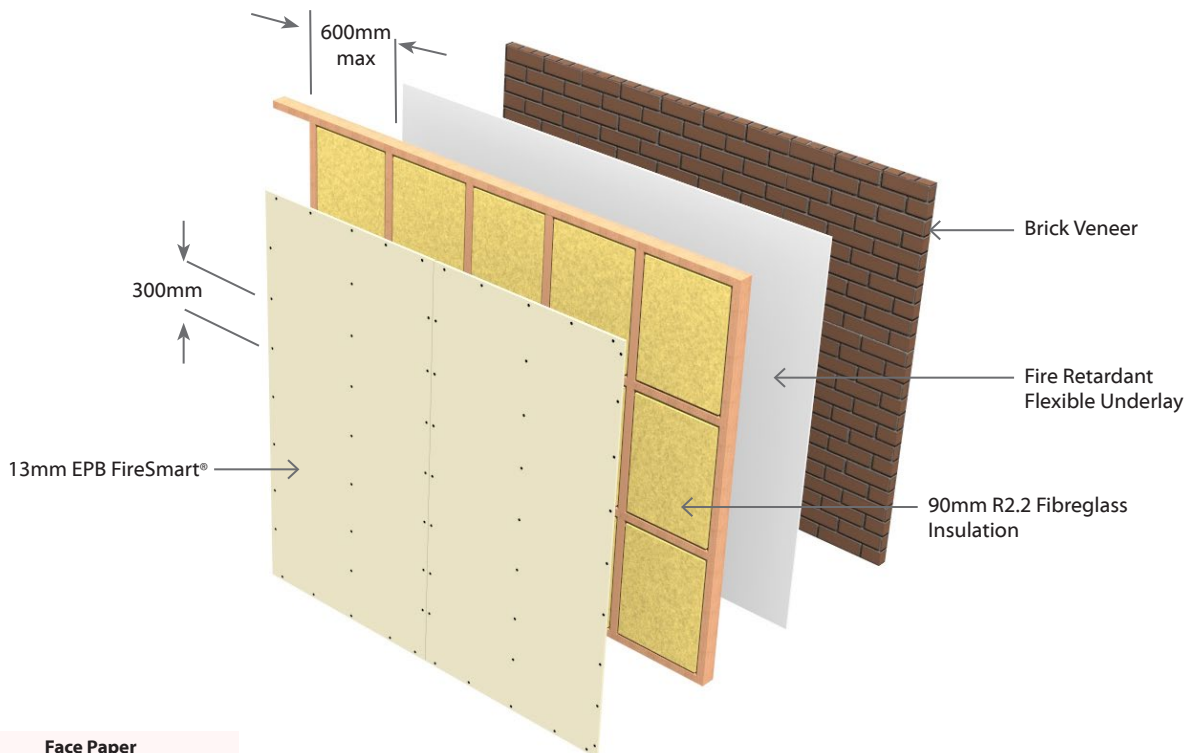

Face Paper	Product Identification Code
13mm EPB FireSmart®	<b>F13</b>



**EGW1TL30**

EPB Plasterboard & GIB Weatherline®

Load Bearing

Two Way FRR

External Wall - Timber Frame

System Number	Lining Suffix	Fire Rating	Load Bearing Ability	Noise Control		Lining Requirement
				STC	Rw	
<b>EGW1TL30</b>	<b>-F10</b>	30/30/30	LB	37	36	1 x 10mm EPB FireSmart® on internal side 1 x 10mm GIB Weatherline® to external side

**Framing**

Framing to comply with NZBC B1: Structure: AS1 Clause 3 – Timber (NZS 3604) or VM1 Clause 6 – Timber (NZS 3603) and NZBC B2: Durability: AS1 Clause 3.2 – Timber (NZS 3602).

Stud size: 90mm minimum.

Studs at 600mm centres maximum.

Nogs at 1350mm centre maximum.

Refer to GIB® Weatherline® Rigid Air Barrier Systems Design and Construction manual for information regarding design requirements and limitations.

**Wall Height, Load and Framing Dimensions**

These are determined by NZS 3604 stud tables for load bearing or non-load bearing partitions.

Refer to GIB Weatherline® Rigid Air Barrier Systems Design and Construction manual regarding design requirements and limitations.

**GIB Weatherline® Sheathing**

One layer of 10mm GIB Weatherline® to external side of the timber framing.

Reference must be made to the GIB Weatherline® Rigid Air Barrier Systems Design and Construction manual for complete installation instructions. Special reference to be made to Fastening lengths, fastening centres, finishing requirements and limitations.

**Wall Insulation**

Usage of Insulation is optional and depends on the building's thermal performance requirement. Acceptable insulation options are mineral wool, glass wool or polyester fibrous insulation.

**EPB Plasterboard Lining**

**NB:** The installer must look for the Product Identification Code on the face paper to ensure the correct board type is installed. Refer to the Face Paper Product Identification Code table on this page.

One layer of 10mm EPB FireSmart® lining on the internal side of the timber framing. Vertical or Horizontal fixing permitted. Use full height or full length sheets where possible when fixing vertically.

All sheet joints must be formed over solid timber framing. Sheets shall be touch fitted.

**Fixing of EPB Plasterboard Internal Linings**

**Fasteners**

41mm x 6g High Thread Drywall Screws

**Fastener Centres**

Fix at 300mm centres at sheet perimeters, on top and bottom plates and 300mm centres up all studs.

Place fasteners no closer than 12mm from the sheet edges and 18mm from sheet ends.

Place fasteners 50mm from sheet corners along the top and bottom plates. On end studs place additional fasteners 50-60mm vertically and no close than 10mm from plate to stud connections.

Place fasteners at 200mm centres where sheet end butt joints occur.

**Jointing and Finishing of EPB Plasterboard**

All fastener heads stopped and all sheet joints reinforced with paper jointing tape and stopped. All in accordance with EPB® Plasterboard Installation Guide.

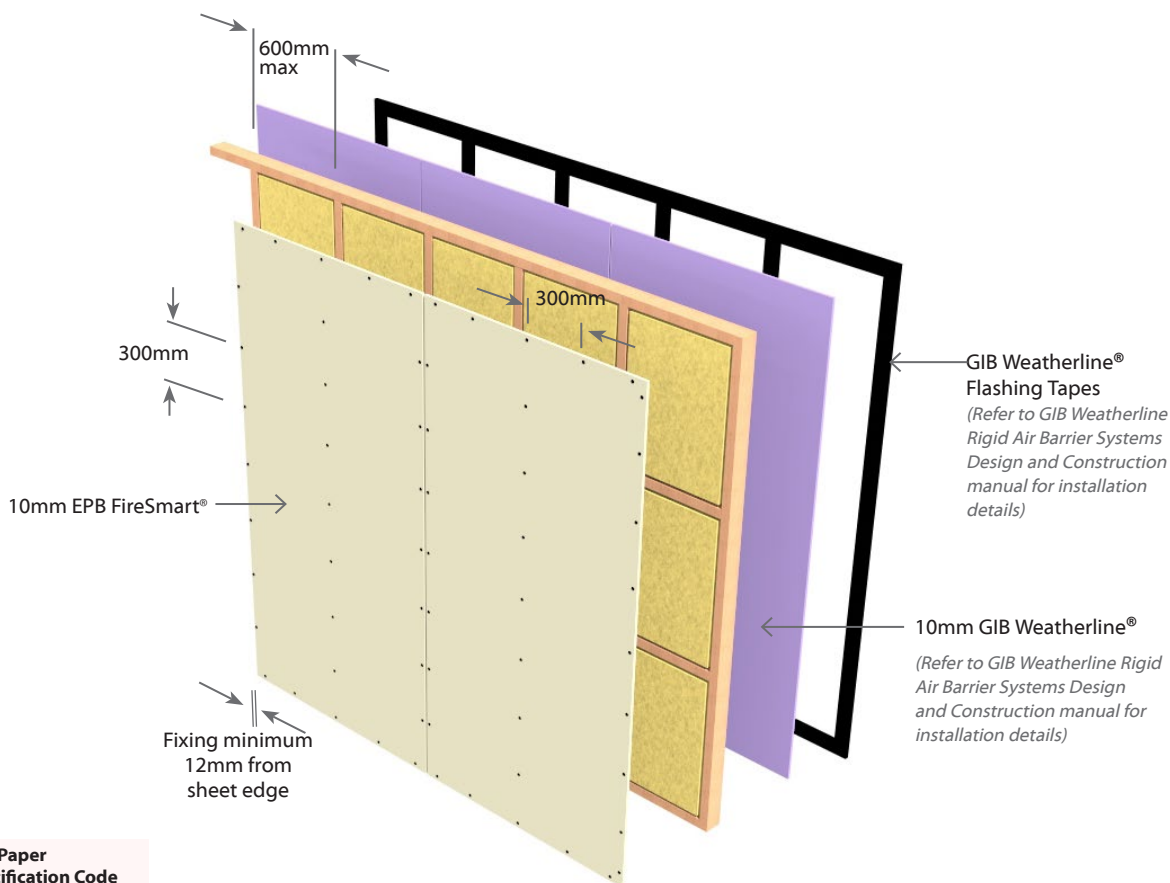

N.B. The above drawing is for illustrative purpose only.



**EGW1TL60**

**EPB Plasterboard & GIB Weatherline®**

**Load Bearing**

**Two Way FRR**

**External Wall - Timber Frame**

System Number	Lining Suffix	Fire Rating	Load Bearing Ability	Noise Control		Lining Requirement
				STC	Rw	
<b>EGW1TL60</b>	<b>-F13</b>	60/60/60	LB	38	37	1 x 13mm EPB FireSmart® on Internal side 1 x 13mm GIB Weatherline® to external side

**Framing**

Framing to comply with NZBC B1: Structure: AS1 Clause 3 – Timber (NZS 3604) or VM1 Clause 6 – Timber (NZS 3603) and NZBC B2: Durability: AS1 Clause 3.2 – Timber (NZS 3602).

Stud size: 90mm minimum.

Studs at 600mm centres maximum.

Nogs at 1350mm centre maximum.

Refer to GIB® Weatherline® Rigid Air Barrier Systems Design and Construction manual for information regarding design requirements and limitations.

**Wall Height, Load and Framing Dimensions**

These are determined by NZS3604 stud tables for load bearing or non-load bearing partitions.

Refer to GIB Weatherline® Rigid Air Barrier Systems Design and Construction manual regarding design requirements and limitations.

**GIB Weatherline® Sheathing**

One layer of 13mm GIB Weatherline® to external side of the timber framing.

Reference must be made to the GIB Weatherline® Rigid Air Barrier Systems Design and Construction manual for complete installation instructions. Special reference to be made to Fastening lengths, fastening centres, finishing requirements and limitations.

**Wall Insulation**

Usage of Insulation is optional and depends on the building's thermal performance requirement. Acceptable insulation options are mineral wool, glass wool or polyester fibrous insulation.

**EPB Plasterboard Lining**

**NB:** The installer must look for the Product Identification Code on the face paper to ensure the correct board type is installed. Refer to the Face Paper Product Identification Code table on this page.

One layer of 13mm EPB FireSmart® lining on the internal side of the timber framing. Vertical or Horizontal fixing permitted. Use full height or full length sheets where possible when fixing vertically.

All sheet joints must be fixed over solid timber framing. Sheets shall be touch fitted.

**Fixing of EPB Plasterboard Internal Linings**

**Fasteners**

41mm x 6g High Thread Drywall Screws

**Fastener Centres**

Fix at 300mm centres at sheet perimeters and on top and bottom plates. And 300mm centres up all studs.

Place fasteners 50mm from sheet corners along the top and bottom plates. On end studs place additional fasteners 50-60mm vertically and no close than 10mm from plate to stud connections.

Place fasteners no closer than 12mm from the sheet edges and 18mm from sheet ends. Place fasteners at 200mm centres where sheet end butt joints occur.

**Jointing and Finishing of EPB Plasterboard**

All fastener heads stopped and all sheet joints reinforced with paper jointing tape and stopped. All in accordance with EPB® Plasterboard Installation Guide.

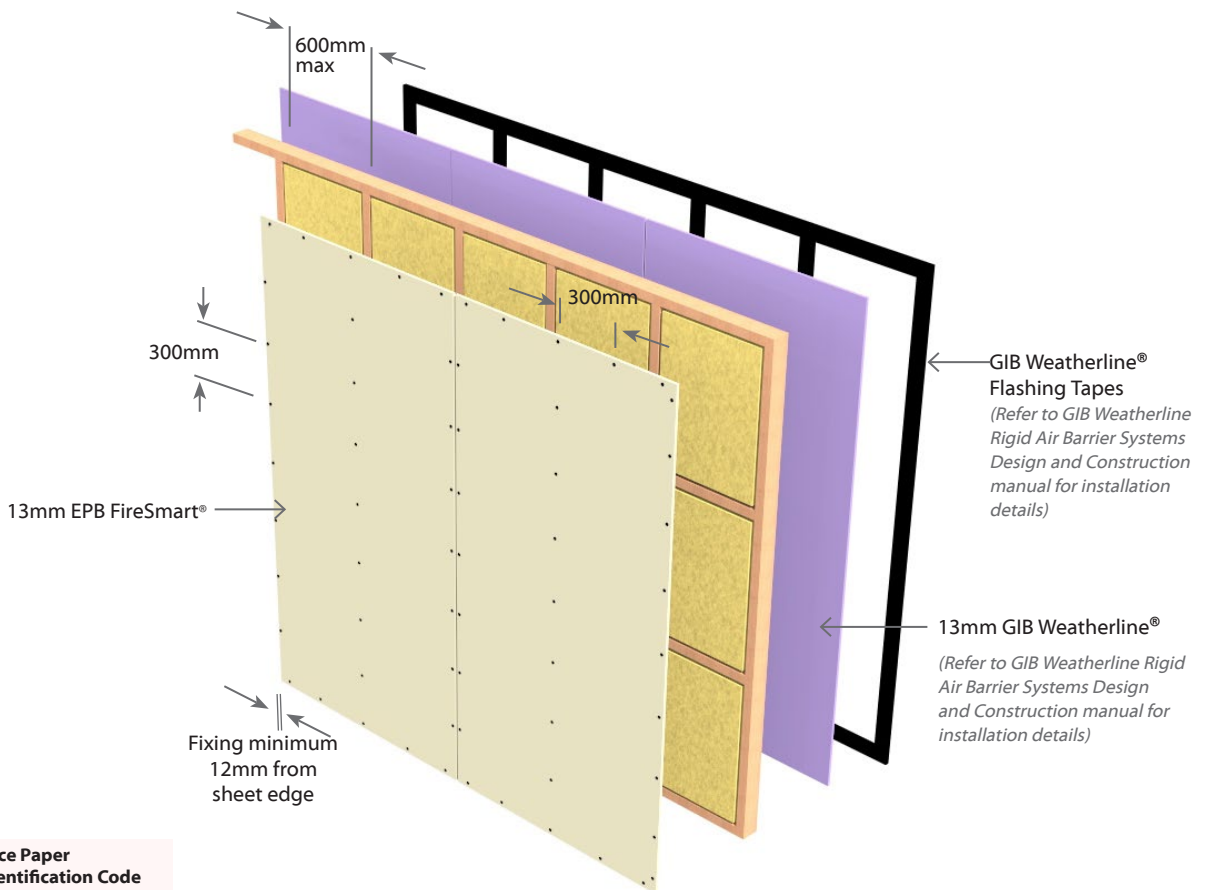

*N.B. The above drawing is for illustrative purpose only.*





# Fire Rated Steel Frame Walls

**2** Layers: 1 Layer of Plasterboard to each side of frame

System Number	Lining Suffix	Fire Rating	Load Bearing Ability	Noise Control		Lining Requirement
				STC	Rw	
<b>E2SL15</b>	<b>-S26</b>	15/15/15	LB	35	34	1 x 13mm EPB® Standard on One side 1 x 13mm EPB® Standard to Other side

**Framing**

Any steel frame designed to meet structural criteria for strength and serviceability under dead and live loads. Stud width shall be 35mm minimum. Stud spacing at 600 centres maximum. Frame heights as determined by specific design.

**Plasterboard Lining**

**NB:** The installer must look for the Product Identification Code on the face paper to ensure the correct board type is installed. Refer to the Face Paper Product Identification Code table on this page.

One layer of 13mm EPB® Standard lining on each side of the steel framing. Vertical or Horizontal fixing permitted. Use full height or full length sheets where possible.

**For Vertical Fixing-** the vertical sheet joints must be offset on the opposite side of the frame.

**For Horizontal Fixing-** the horizontal sheet joints must be formed over nogs and must be offset on the other side of the frame.

**Sheet end butt joints-** must be formed over framing and staggered. Offset joints from opposite side of the frame.

All sheet joints must be formed over framing.

The layers are fixed hard to the floor.

Sheets shall be touch fitted.

**Fixing of Linings**

**Fasteners**

System Number	Side One	Side Two
	Single Layer	
Self-Tapping Drywall Screws		
<b>E2SL15-S26</b>	13mm	13mm
	25 x 6g	25 x 6g

**Fastener Centres**

Fix at 300mm centres up each stud with no fixing to top and bottom track sections.

Place fasteners no closer than 12mm to the sheet edge and 50mm from sheet ends.

Place fasteners at 200mm centres where sheet end butt joints occur.

**Jointing**

All fastener heads stopped and all sheet joints reinforced with paper jointing tape and stopped. All in accordance with the EPB® Plasterboard Installation Guide.

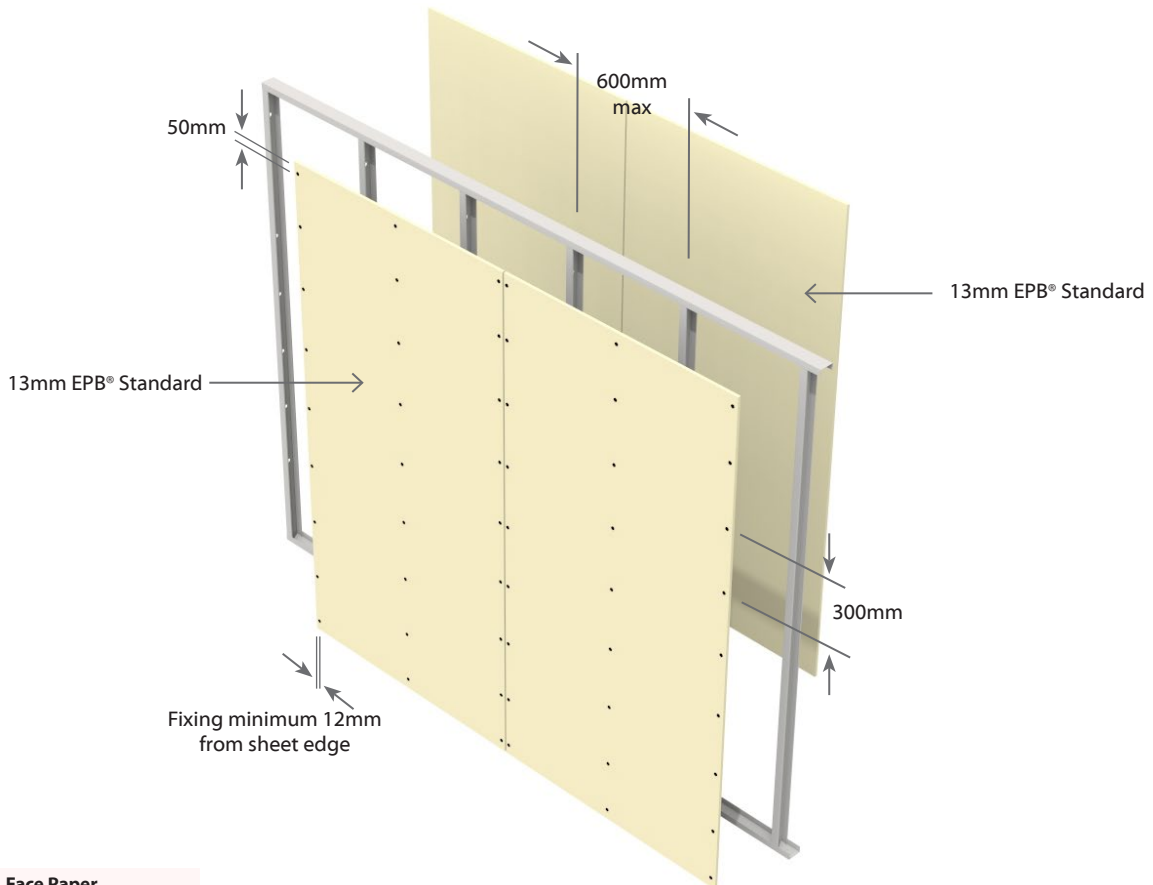

Face Paper Product Identification Code	
13mm EPB® Standard	<b>S13</b>



**E2S30**

Single Steel Frame

Non Load Bearing

Two Way FRR

**2 Layers:** 1 Layer of Plasterboard to each side of frame

System Number	Lining Suffix	Fire Rating	Load Bearing Ability	Noise Control		Lining Requirement
				STC	Rw	
<b>E2S30</b>	<b>-S26</b>	-/30/30	NLB	35	34	1 x 13mm EPB® Standard on One side 1 x 13mm EPB® Standard to Other side
	<b>-M20</b>	-/30/30	NLB	36	35	1 x 10mm EPB MultiSmart® on One side 1 x 10mm EPB MultiSmart® to Other side

**Framing**

Steel studs with minimum dimensions 64mm x 34mm x 0.50 BMT with 6mm return.

Tracks to be minimum dimensions 64mm x 30mm x 0.50 BMT.

Top & bottom tracks are fixed to the floor and ceiling in true alignment.

Studs are placed at 600mm centres maximum.

Place studs to allow the nominated expansion gap (minimum 15mm) at the top of frame. The studs cannot be directly fixed to the tracks. The studs are held in place by the grip of the track runners.

**Wall Height**

Recommended maximum height is 3.0m. For higher walls refer to steel stud height table below.

Stud Dimensions (mm)	Base Metal Thickness (mm)	Stud Centres (mm)	Max Wall Heights (mm)	Expansion Tolerance at top of studs (mm)
<b>64 x 34</b>	0.50	600	3000	15
		400	3200	15
<b>76 x 34</b>	0.55	600	3200	15
		400	3800	20*
	0.75	600	3600	20*
		400	4200	20*
<b>92 x 34</b>	0.75	600	4200	20*
		400	4800	25*

\* Use a minimum 50mm deep head track

**Plasterboard Lining**

NB: The installer must look for the Product Identification Code on the face paper to ensure the correct board type is installed. Refer to the Face Paper Product Identification Code table on this page.

One layer of EPB® Plasterboard lining as per specified system above on each side of the steel framing. Vertical fixing only permitted. Use full height sheets where possible.

**Vertical Fixing-** the vertical sheet joints must be offset on the opposite side of the frame.

**Sheet end butt joints-** must be formed over framing and staggered. Offset joints from opposite side of the frame.

All sheet joints must be formed over framing.

The layers are fixed hard to the floor. Sheets shall be touch fitted.

**Fixing of Linings**

**Fasteners (As per Specified System Above)**

System Number	Fasteners	
	Side One	Side Two
	Single Layer Self-Tapping Drywall Screws	
<b>E2S30-S26</b>	13mm	13mm
	25 x 6g	25 x 6g
<b>E2S30-M20</b>	10mm	10mm
	25 x 6g	25 x 6g

**Fastener Centres**

Fix at 300mm centres up each stud with no fixing to top and bottom track sections. Place fasteners no closer than 12mm to the sheet edge and 50mm from sheet ends and min 20mm clear of top and bottom tracks.

Place fasteners at 200mm centres where sheet end butt joints occur.

Fasteners may be placed at 18mm from sheet ends along top and bottom tracks, provided the fasteners do not connect the stud to the track. If floor deflections need to be considered, do not fix any linings to top track.

**Jointing**

All fastener heads stopped and all sheet joints reinforced with paper jointing tape and stopped. All in accordance with EPB® Plasterboard Installation Guide.

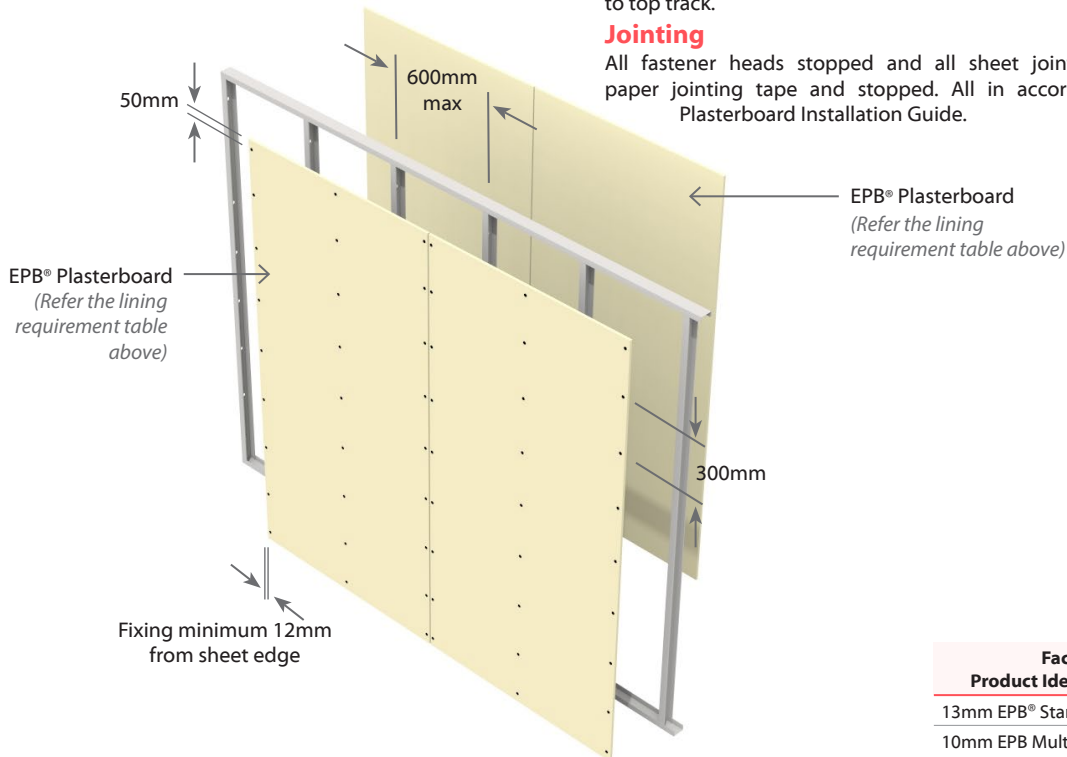

Face Paper Product Identification Code	
13mm EPB® Standard	<b>S13</b>
10mm EPB MultiSmart®	<b>M10</b>



2 Layers: 1 Layer of Plasterboard to each side of frame

System Number	Lining Suffix	Fire Rating	Load Bearing Ability	Noise Control		Lining Requirement
				STC	Rw	
E2SL30	-M26	30/30/30	LB	37	36	1 x 13mm EPB MultiSmart® on One side 1 x 13mm EPB MultiSmart® to Other side
	-F32	30/30/30	LB	37	36	1 x 16mm EPB FireSmart® on One side 1 x 16mm EPB FireSmart® to Other side

**Framing**

Any steel frame designed to meet structural criteria for strength and serviceability under dead and live loads. Stud width shall be 35mm minimum. Stud spacing at 600 centres maximum. Frame heights as determined by specific design.

**Plasterboard Lining**

**NB:** The installer must look for the Product Identification Code on the face paper to ensure the correct board type is installed. Refer to the Face Paper Product Identification Code table on this page.

One layer of EPB® Plasterboard lining as per specified system above on each side of the steel framing.

Vertical or Horizontal fixing permitted. Use full height or full length sheets where possible.

**For Vertical Fixing-** the vertical sheet joints must be offset on the opposite side of the frame.

**For Horizontal Fixing-** the horizontal sheet joints must be formed over nogs and must be offset on the other side of the frame.

**Sheet end butt joints-** must be formed over framing and staggered. Offset joints from opposite side of the frame.

All sheet joints must be formed over framing.

The layers are fixed hard to the floor. Sheets shall be touch fitted.

**Fixing of Linings**

**Fasteners (As per Specified System Above)**

System Number	Side One	Side Two
	Single Layer Self-Tapping Drywall Screws	
E2SL30-M26	13mm	13mm
	25 x 6g	25 x 6g
E2SL30-F32	16mm	16mm
	32 x 6g	32 x 6g

**Fastener Centres**

Fix at 300mm centres up each stud with no fixing to top and bottom track sections.

Place fasteners no closer than 12mm to the sheet edge and 50mm from sheet ends.

Place fasteners at 200mm centres where sheet end butt joints occur.

**Jointing**

All fastener heads stopped and all sheet joints reinforced with paper jointing tape and stopped. All in accordance with the EPB® Plasterboard Installation Guide.

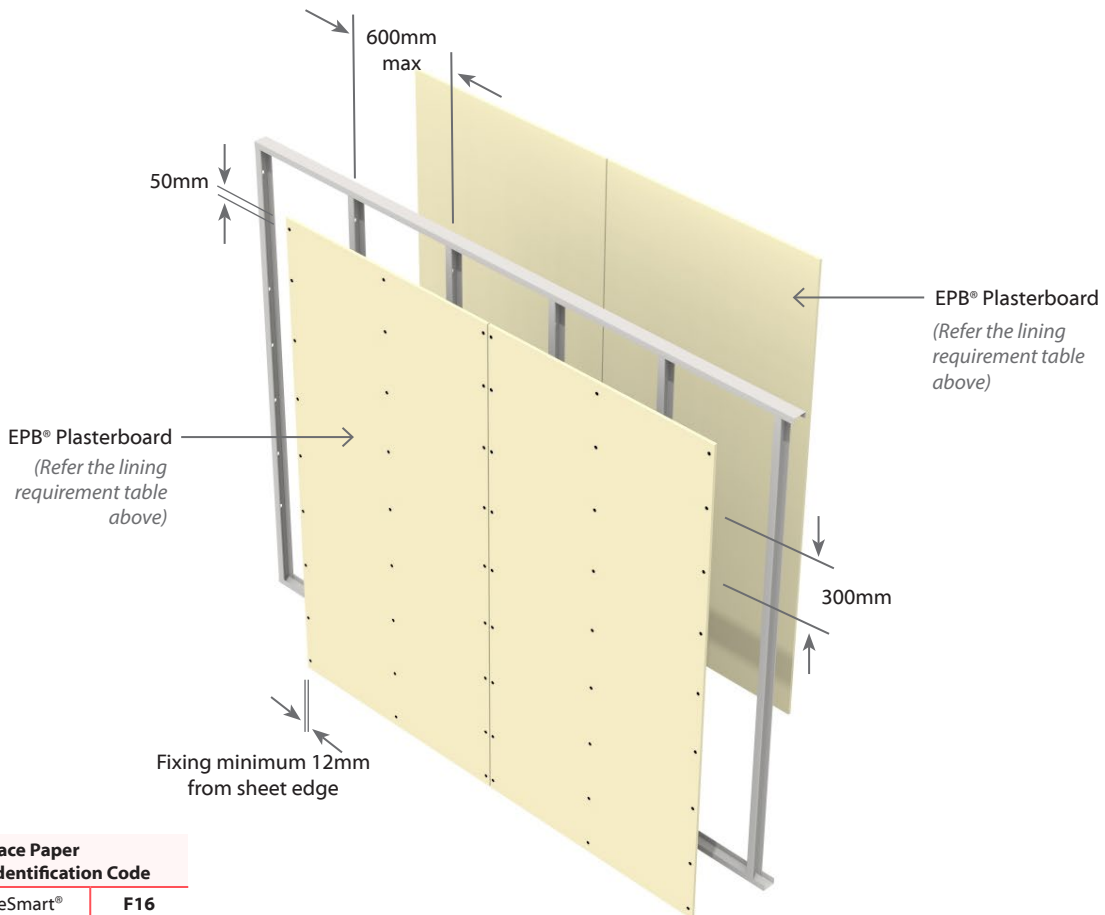

Face Paper Product Identification Code	
16mm EPB FireSmart®	F16
13mm EPB MultiSmart®	M13



**E4SL30**

Single Steel Frame

Load Bearing

Two Way FRR

**4** Layers: 2 Layers of Plasterboard to each side of frame

System Number	Lining Suffix	Fire Rating	Load Bearing Ability	Noise Control		Lining Requirement
				STC	Rw	
E4SL30	-F40	30/30/30	LB	43	42	2 x 10mm EPB FireSmart® on One side 2 x 10mm EPB FireSmart® to Other side
	-S52	30/30/30	LB	43	42	2 x 13mm EPB® Standard on One side 2 x 13mm EPB® Standard to Other side

**Framing**

Any steel frame designed to meet structural criteria for strength and serviceability under dead and live loads. Stud width shall be 35mm minimum. Stud spacing at 600 centres maximum.

Frame heights as determined by specific design.

**Plasterboard Lining**

**NB:** The installer must look for the Product Identification Code on the face paper to ensure the correct board type is installed. Refer to the Face Paper Product Identification Code table on this page.

Two layers of EPB® Plasterboard lining as per specified system above on each side of the steel framing.

Vertical or Horizontal fixing permitted. Use full height or full length sheets where possible.

**For Vertical Fixing-** the vertical sheet joints must be offset on the opposite side of the frame.

**For Horizontal Fixing-** the horizontal sheet joints must be formed over nogs and must be offset on the other side of the frame.

**Sheet end butt joints-** must be formed over framing and staggered. Offset joints from opposite side of the frame.

All outer layer joints must be staggered from inner layer joints.

All sheet joints must be formed over framing.

The layers are fixed hard to the floor. Sheets shall be touch fitted.

**Fixing of Linings**

**Fasteners**

System Number	Side One		Side Two	
	1 <sup>st</sup> Layer	2 <sup>nd</sup> Layer	1 <sup>st</sup> Layer	2 <sup>nd</sup> Layer
Self-Tapping Drywall Screws				
E4SL30-F40	10mm	10mm	10mm	10mm
	25 x 6g	32 x 6g	25 x 6g	32 x 6g
E4SL30-S52	13mm	13mm	13mm	13mm
	25 x 6g	41 x 6g	25 x 6g	41 x 6g

**Fastener Centres**

Inner Layer: Fix at 600mm centres up each stud with no fixing to top and bottom track sections.

Outer Layer: Fix at 300mm centres up each stud with no fixing to top and bottom track sections.

Place fasteners no closer than 12mm to the sheet edge and 50mm from sheet ends.

Place fasteners at 200mm centres where sheet end butt joints occur.

Avoid outer layer screws from hitting inner layer screws.

**Jointing**

Inner Layer: Unstopped

Outer Layer: All fastener heads stopped and all sheet joints reinforced with paper jointing tape and stopped. All in accordance with EPB® Plasterboard Installation Guide.

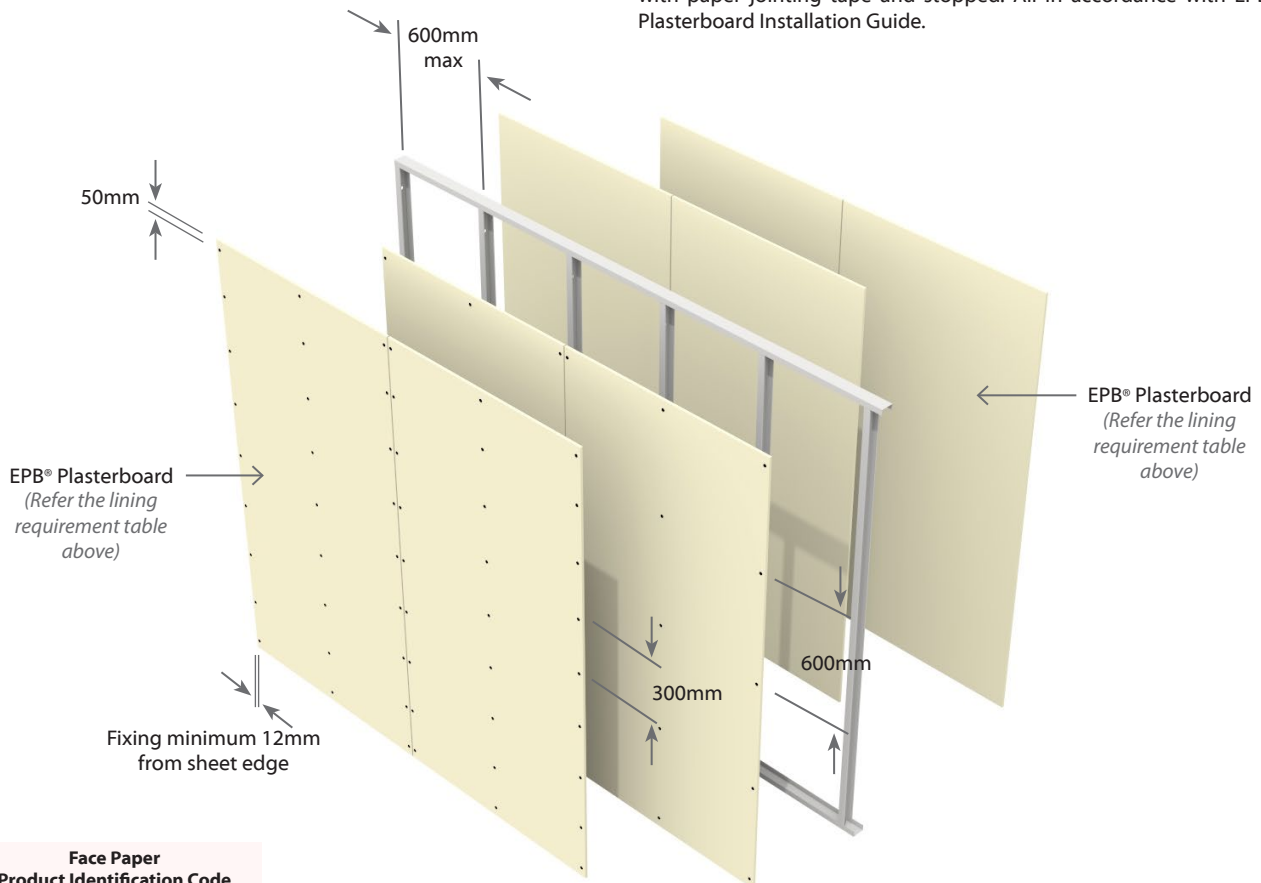

Face Paper Product Identification Code	
13mm EPB® Standard	S13
10mm EPB FireSmart®	F10



**2 Layers: 1 Layer of Plasterboard to each side of frame**

System Number	Lining Suffix	Fire Rating	Load Bearing Ability	Noise Control		Lining Requirement
				STC	Rw	
<b>E2S60</b>	<b>-F26</b>	-/60/60	NLB	37	36	1 x 13mm EPB FireSmart® on One side 1 x 13mm EPB FireSmart® to Other side

**Framing**

Steel studs with minimum dimensions 64mm x 34mm x 0.50 BMT with 6mm return.

Tracks to be minimum dimensions 64mm x 30mm x 0.50 BMT.

Top & bottom tracks are fixed to the floor and ceiling in true alignment. Studs are placed at 600mm centres maximum.

Place studs to allow the nominated expansion gap (minimum 15mm) at the top of frame. The studs cannot be directly fixed to the tracks. The studs are held in place by the grip of the track runners.

**Wall Height**

Recommended maximum height is 3.0m. For higher walls refer to steel stud height table below.

Stud Dimensions (mm)	Base Metal Thickness (mm)	Stud Centres (mm)	Max Wall Heights (mm)	Expansion Tolerance at top of studs (mm)
<b>64 x 34</b>	0.50	600	3000	15
		400	3200	15
<b>76 x 34</b>	0.55	600	3200	15
		400	3800	20*
	0.75	600	3600	20*
		400	4200	20*
<b>92 x 34</b>	0.75	600	4200	20*
		400	4800	25*

\* Use a minimum 50mm deep head track

**Wall Insulation**

Minimum 75mm thick R1.8 glass wool blanket wall insulation must be installed between studs of the frame.

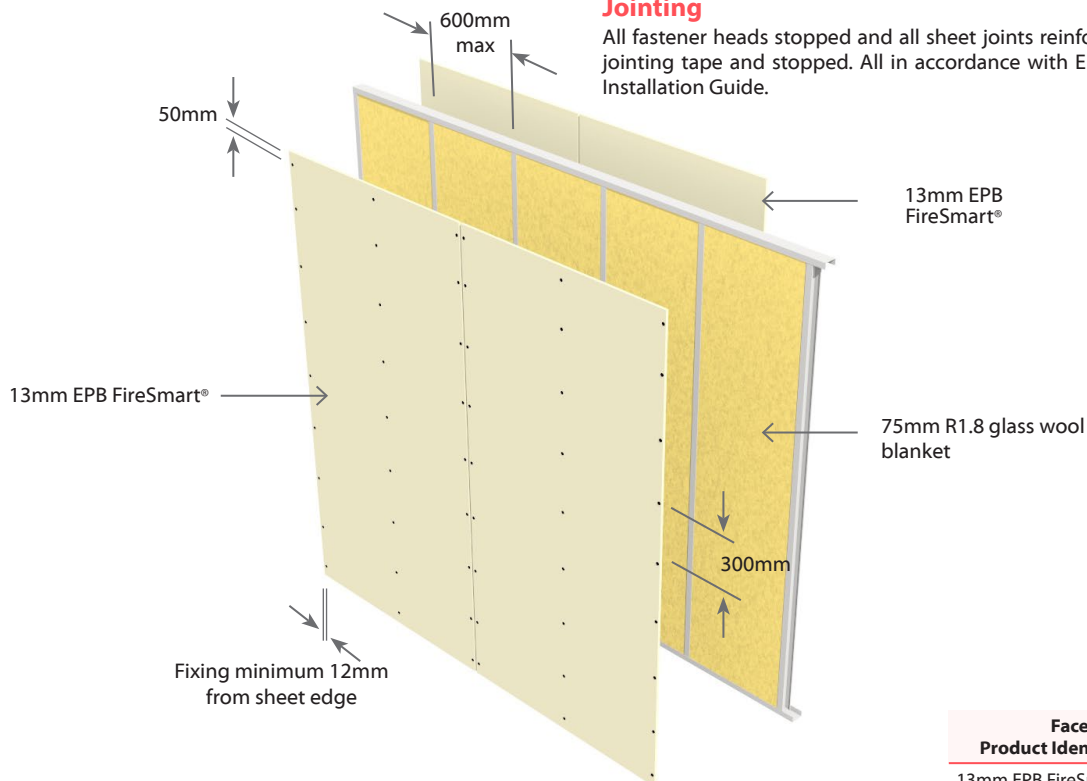

**Plasterboard Lining**

**NB:** The installer must look for the Product Identification Code on the face paper to ensure the correct board type is installed. Refer to the Face Paper Product Identification Code table on this page.

One layer of 13mm EPB FireSmart® lining on each side of the steel framing. Vertical fixing only permitted. Use full height sheets where possible.

**Vertical Fixing-** the vertical sheet joints must be offset on the opposite side of the frame.

**Sheet end butt joints-** must be formed over framing and staggered. Offset joints from opposite side of the frame.

All sheet joints must be formed over framing.

The layers are fixed hard to the floor.

Sheets shall be touch fitted.

**Fixing of Linings**

**Fasteners**

System Number	Side One	Side Two
	Single Layer	
	Self-Tapping Drywall Screws	
<b>E2S60-F26</b>	13mm	13mm
	25 x 6g	25 x 6g

**Fastener Centres**

Fix at 300mm centres up each stud with no fixing to top and bottom track sections. Place fasteners no closer than 12mm to the sheet edge and 50mm from sheet ends and min 20mm clear of top and bottom tracks.

Place fasteners at 200mm centres where sheet end butt joints occur.

Fasteners may be placed at 18mm from sheet ends along top and bottom tracks, provided the fasteners do not connect the stud to the track. If floor deflections need to be considered, do not fix any linings to top track.

**Jointing**

All fastener heads stopped and all sheet joints reinforced with paper jointing tape and stopped. All in accordance with EPB® Plasterboard Installation Guide.

Face Paper Product Identification Code	
13mm EPB FireSmart®	<b>F13</b>



**E4S60**

Single Steel Frame

Non Load Bearing

Two Way FRR

**4** Layers: 2 Layers of Plasterboard to each side of frame

System Number	Lining Suffix	Fire Rating	Load Bearing Ability	Noise Control		Lining Requirement
				STC	Rw	
<b>E4S60</b>	<b>-S52</b>	-/60/60	NLB	45	44	2 x 13mm EPB® Standard on One side 2 x 13mm EPB® Standard to Other side
	<b>-M40</b>	-/60/60	NLB	45	44	2 x 10mm EPB MultiSmart® on One side 2 x 10mm EPB MultiSmart® to Other side

**Framing**

Steel studs with minimum dimensions 64mm x 34mm x 0.50 BMT with 6mm return.

Tracks to be minimum dimensions 64mm x 30mm x 0.50 BMT.

Top & bottom tracks are fixed to the floor and ceiling in true alignment. Studs are placed at 600mm centres maximum.

Place studs to allow the nominated expansion gap (minimum 15mm) at the top of frame. The studs cannot be directly fixed to the tracks. The studs are held in place by the grip of the track runners.

**Wall Height**

Recommended maximum height is 3.0m. For higher walls refer to steel stud height table below.

Stud Dimintions (mm)	Base Metal Thickness (mm)	Stud Centres (mm)	Max Wall Heights (mm)	Expansion Tolerance at top of studs (mm)
<b>64 x 34</b>	0.50	600	3000	15
		400	3200	15
<b>76 x 34</b>	0.55	600	3200	15
		400	3800	20*
	0.75	600	3600	20*
		400	4200	20*
<b>92 x 34</b>	0.75	600	4200	20*
		400	4800	25*

\* Use a minimum 50mm deep head track

**Plasterboard Lining**

**NB:** The installer must look for the Product Identification Code on the face paper to ensure the correct board type is installed. Refer to the Face Paper Product Identification Code table on this page.

Two layers of EPB® Plasterboard lining as per specified system above on each side of the steel framing. Vertical fixing only permitted. Use full height sheets where possible.

**Vertical Fixing-** the vertical sheet joints must be offset on the opposite side of the frame.

**Sheet end butt joints-** must be formed over framing and staggered. Offset joints from opposite side of the frame.

All outer layer joints must be staggered from inner layer joints.

All sheet joints must be formed over framing. The layers are fixed hard to the floor. Sheets shall be touch fitted.

**Fixing of Linings**

**Fasteners (As per Specified System Above)**

System Number	Side One		Side Two	
	1 <sup>st</sup> Layer	2 <sup>nd</sup> Layer	1 <sup>st</sup> Layer	2 <sup>nd</sup> Layer
	Self-Tapping Drywall Screws			
<b>E4S60-S52</b>	13mm	13mm	13mm	13mm
	25 x 6g	41 x 6g	25 x 6g	41 x 6g
<b>E4S60-M40</b>	10mm	10mm	10mm	10mm
	25 x 6g	41 x 6g	25 x 6g	41 x 6g

**Fastener Centres**

Inner Layer: Fix at 600mm centres up each stud with no fixing to top or bottom track sections.

Outer Layer: Fix at 300mm centres up each stud with no fixing to top and bottom track sections.

Place fasteners no closer than 12mm to the sheet edge and 50mm from sheet ends and min 20mm clear of top and bottom tracks.

Place fasteners at 200mm centres where sheet end butt joints occur. Avoid outer layer screws from hitting inner layer screws.

Fasteners may be placed at 18mm from sheet ends along top and bottom tracks, provided the fasteners do not connect the stud to the track. If floor deflections need to be considered, do not fix any linings to top track.

**Jointing**

Inner Layer: Unstopped

Outer Layer: All fastener heads stopped and all sheet joints reinforced with paper jointing tape and stopped.

All in accordance with EPB® Plasterboard Installation Guide.

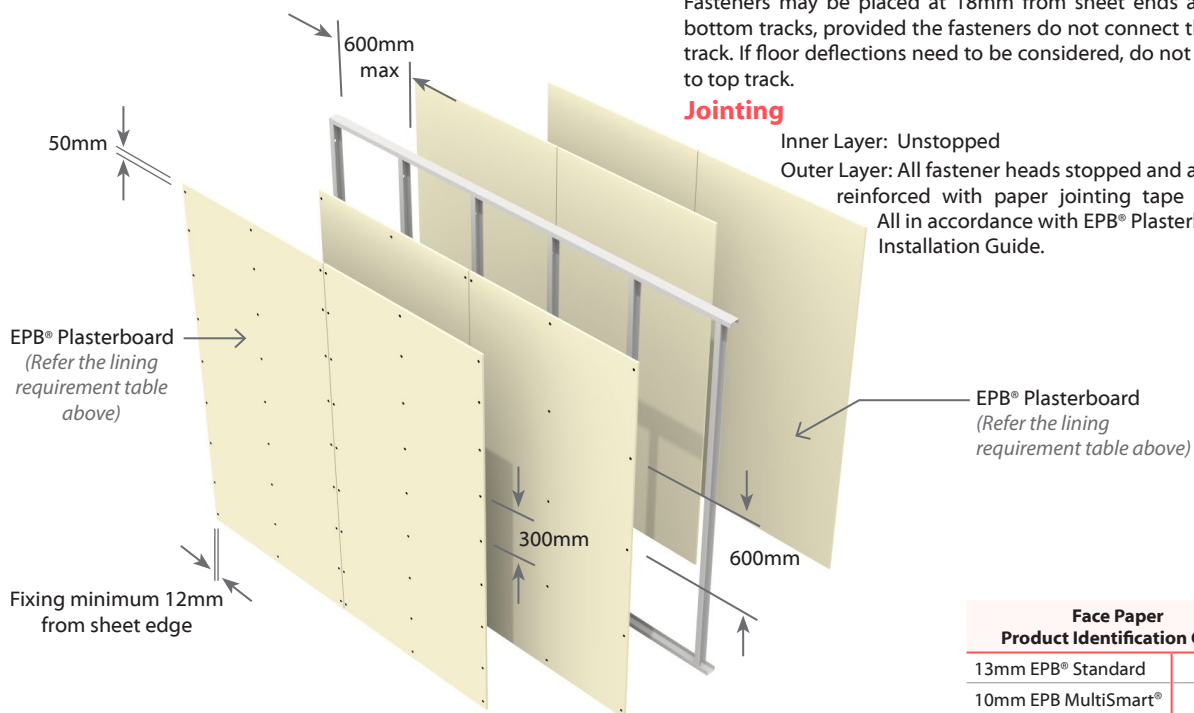

Face Paper Product Identification Code	
13mm EPB® Standard	<b>S13</b>
10mm EPB MultiSmart®	<b>M10</b>



**4** Layers: 2 Layers of Plasterboard to each side of frame

System Number	Lining Suffix	Fire Rating	Load Bearing Ability	Noise Control		Lining Requirement
				STC	Rw	
<b>E4SL60</b>	<b>-F52</b>	60/60/60	LB	46	45	2 x 13mm EPB FireSmart® on One side 2 x 13mm EPB FireSmart® to Other side

**Framing**

Any steel frame designed to meet structural criteria for strength and serviceability under dead and live loads. Stud width shall be 35mm minimum. Stud spacing at 600 centres maximum. Frame heights as determined by specific design.

**Plasterboard Lining**

**NB:** The installer must look for the Product Identification Code on the face paper to ensure the correct board type is installed. Refer to the Face Paper Product Identification Code table on this page.

Two layers of 13mm EPB FireSmart® plasterboard lining on each side of the steel framing.

Vertical or Horizontal fixing permitted. Use full height or full length sheets where possible. All vertical joints of the inner layer must be formed over framing. Vertical joints of the outer layer should be offset to those of the inner layer. The layers are fixed hard to the floor. Sheets shall be touch fitted.

Where sheet end butt joints are unavoidable, the inner layer joints must be formed over nogs. Stagger the outer layer butt joints from the inner layer by minimum 100mm.

**Fixing of Linings**

**Fasteners**

System Number	Side One		Side Two	
	1 <sup>st</sup> Layer	2 <sup>nd</sup> Layer	1 <sup>st</sup> Layer	2 <sup>nd</sup> Layer
Self-Tapping Drywall Screws				
<b>E4SL60-F52</b>	13mm	13mm	13mm	13mm
	25 x 6g	41 x 6g	25 x 6g	41 x 6g

**Fastener Centres**

Inner Layer: Fix at 600mm centres up each stud with no fixing to top and bottom track sections.

Outer Layer: Fix at 300mm centres up each stud with no fixing to top and bottom track sections.

Place fasteners no closer than 12mm to the sheet edge and 50mm from sheet ends.

Place fasteners at 200mm centres where sheet end butt joints occur. Avoid outer layer screws from hitting inner layer screws.

**Joining**

Inner Layer: Unstopped

Outer Layer: All fastener heads stopped and all sheet joints reinforced with paper jointing tape and stopped. All in accordance with EPB® Plasterboard Installation Guide.

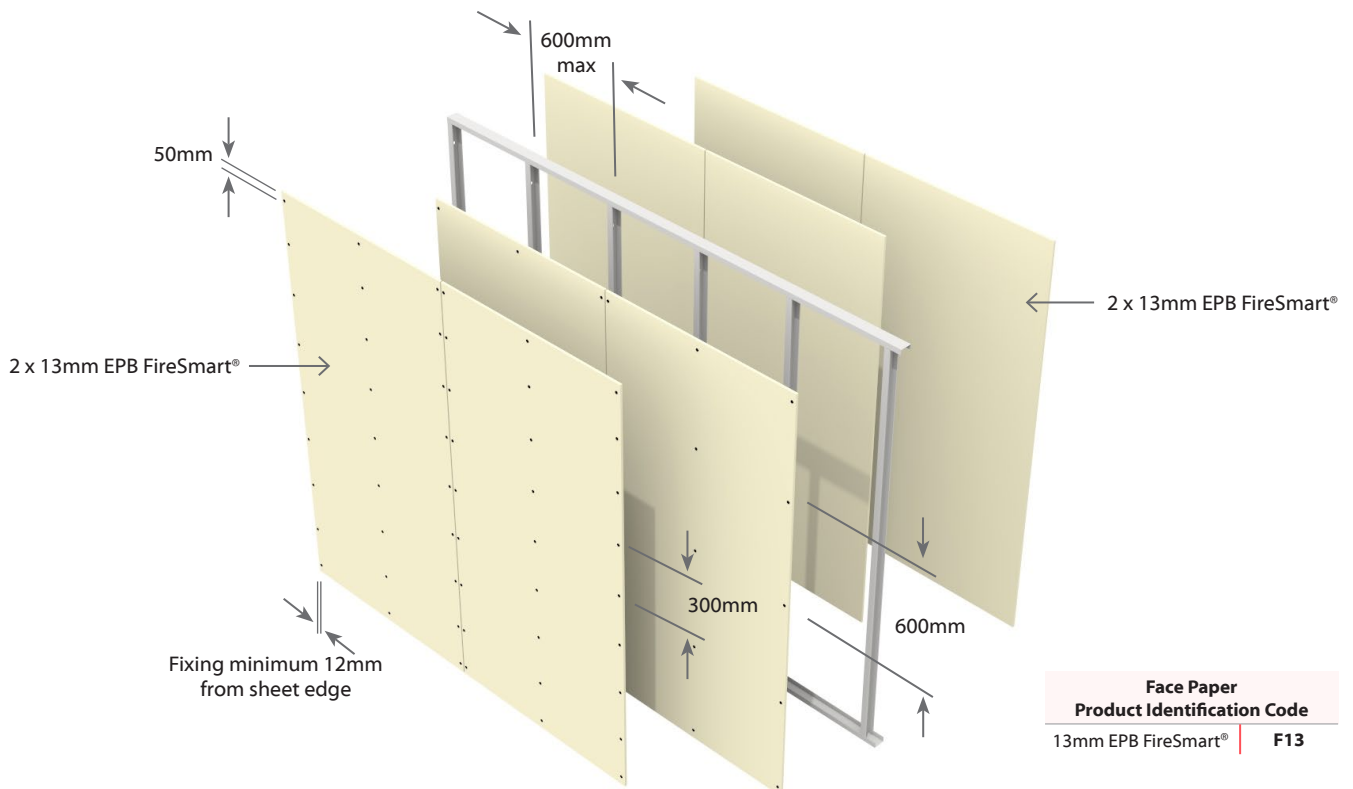

**2** Layers: 1 Layer of Plasterboard to each side of frame

System Number	Lining Suffix	Fire Rating	Load Bearing Ability	Noise Control		Lining Requirement
				STC	Rw	
<b>E2S75</b>	<b>-F32</b>	-/75/75	NLB	38	37	1 x 16mm EPB FireSmart® on One side 1 x 16mm EPB FireSmart® to Other side

**Framing**

Steel studs with minimum dimensions 92mm x 34mm x 0.75 BMT with 6mm return.  
 Bottom tracks to be minimum dimensions 92mm x 30mm x 0.75 BMT.  
 Top tracks to be minimum dimensions 92mm x 50mm x 0.75 BMT.  
 Top & bottom tracks are fixed to the floor and ceiling in true alignment.  
 Studs are placed at 600mm centres maximum.  
 Place studs to allow the nominated expansion gap (minimum 15mm) at the top of frame. The studs cannot be directly fixed to the tracks. The studs are held in place by the grip of the track runners.

**Wall Height**

Recommended maximum height is 3.0m. For higher walls refer to steel stud height table below.

Stud Dimentions (mm)	Base Metal Thickness (mm)	Stud Centres (mm)	Max Wall Heights (mm)	Expansion Tolerance at top of studs (mm)
<b>92 x 34</b>	0.75	600	3000	15
		400	3400	15
<b>150 x 34</b>	0.75	600	4400	20*
		400	5000	25*
	1.15	600	5000	25*
		400	5700	30*

\* Use a minimum 50mm deep head track

**Plasterboard Lining**

**NB:** The installer must look for the Product Identification Code on the face paper to ensure the correct board type is installed. Refer to the Face Paper Product Identification Code table on this page.

One layer of 16mm EPB FireSmart® lining on each side of the steel framing. Vertical fixing only permitted. Use full height sheets where possible.

**Vertical Fixing**- the vertical sheet joints must be offset on the opposite side of the frame.

**Sheet end butt joints**- must be formed over framing and staggered. Offset joints from opposite side of the frame.

All sheet joints must be formed over framing. The layers are fixed hard to the floor. Sheets shall be touch fitted.

**Fixing of Linings Fasteners**

System Number	Side One	Side Two
	Single Layer Self-Tapping Drywall Screws	
<b>E2S75-F32</b>	16mm	16mm
	32 x 6g	32 x 6g

**Fastener Centres**

Fix at 150mm centres up sheet edges and 300mm centres up each intermediate stud with no fixing to top and bottom track sections. Place fasteners no closer than 12mm to the sheet edge and 50mm from sheet ends and min 20mm clear of top and bottom tracks.

Place fasteners at 200mm centres where sheet end butt joints occur. Fasteners may be placed at 18mm from sheet ends along top and bottom tracks, provided the fasteners do not connect the stud to the track. If floor deflections need to be considered, do not fix any linings to top track.

**Jointing**

All fastener heads stopped and all sheet joints reinforced with paper jointing tape and stopped. All in accordance with EPB® Plasterboard Installation Guide.

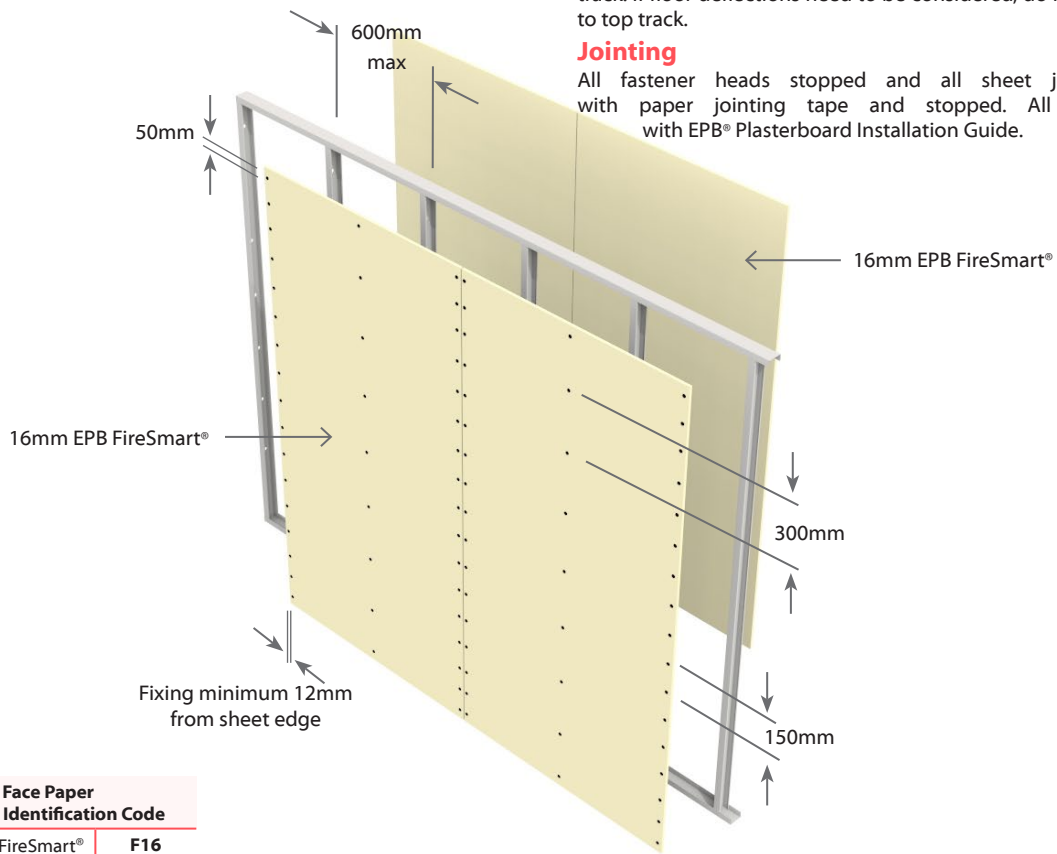

4 Layers: 2 Layers of Plasterboard to each side of frame

System Number	Lining Suffix	Fire Rating	Load Bearing Ability	Noise Control		Lining Requirement
				STC	Rw	
E4S90	-M46	-/90/90	NLB	45	44	1 x 10mm EPB MultiSmart® & 1 x 13mm EPB MultiSmart® One side 1 x 10mm EPB MultiSmart® & 1 x 13mm EPB MultiSmart® Other side

**Framing**

Steel studs with minimum dimensions 92mm x 34mm x 0.75 BMT with 6mm return.

Bottom tracks to be minimum dimensions 92mm x 30mm x 0.75 BMT.

Top tracks to be minimum dimensions 92mm x 50mm x 0.75 BMT.

Top & bottom tracks are fixed to the floor and ceiling in true alignment.

Studs are placed at 600mm centres maximum.

Place studs to allow the nominated expansion gap (minimum 15mm) at the top of frame. The studs cannot be directly fixed to the tracks. The studs are held in place by the grip of the track runners.

**Wall Height**

Recommended maximum height is 3.0m. For higher walls refer to steel stud height table below.

Stud Dimensions (mm)	Base Metal Thickness (mm)	Stud Centres (mm)	Max Wall Heights (mm)	Expansion Tolerance at top of studs (mm)
92 x 34	0.75	600	3000	15
		400	3400	15
150 x 34	0.75	600	4400	20*
		400	5000	25*
	1.15	600	5000	25*
		400	5700	30*

\* Use a minimum 50mm deep head track

**Plasterboard Lining**

**NB:** The installer must look for the Product Identification Code on the face paper to ensure the correct board type is installed. Refer to the Face Paper Product Identification Code table on this page.

One layer of 10mm EPB MultiSmart® & One layer of 13mm EPB MultiSmart® lining on each side of the steel framing.

Vertical fixing only permitted. Use full height sheets where possible.

**Vertical Fixing-** the vertical sheet joints must be offset on the opposite side of the frame.

**Sheet end butt joints-** must be formed over framing and staggered. Offset joints from opposite side of the frame.

All outer layer joints must be staggered from inner layer joints.

All sheet joints must be formed over framing. The layers are fixed hard to the floor. Sheets shall be touch fitted.

**Fixing of Linings**

**Fasteners (As per Specified System Above)**

System Number	Side One		Side Two	
	1 <sup>st</sup> Layer	2 <sup>nd</sup> Layer	1 <sup>st</sup> Layer	2 <sup>nd</sup> Layer
E4S90-M46	Self-Tapping Drywall Screws			
	10mm	13mm	10mm	13mm
	25 x 6g	41 x 6g	25 x 6g	41 x 6g

**Fastener Centres**

Inner Layer: Fix at 300mm centres up each stud with no fixing to top or bottom track sections.

Outer Layer: Fix at 300mm centres up each stud with no fixing to top and bottom track sections.

Place fasteners no closer than 12mm to the sheet edge and 50mm from sheet ends and min 20mm clear of top and bottom tracks.

Place fasteners at 200mm centres where sheet end butt joints occur. Avoid outer layer screws from hitting inner layer screws.

Fasteners may be placed at 18mm from sheet ends along top and bottom tracks, provided the fasteners do not connect the stud to the track. If floor deflections need to be considered, do not fix any linings to top track.

**Jointing**

Inner Layer: Unstopped

Outer Layer: All fastener heads stopped and all sheet joints reinforced with paper jointing tape and stopped. All in accordance with EPB® Plasterboard Installation Guide.

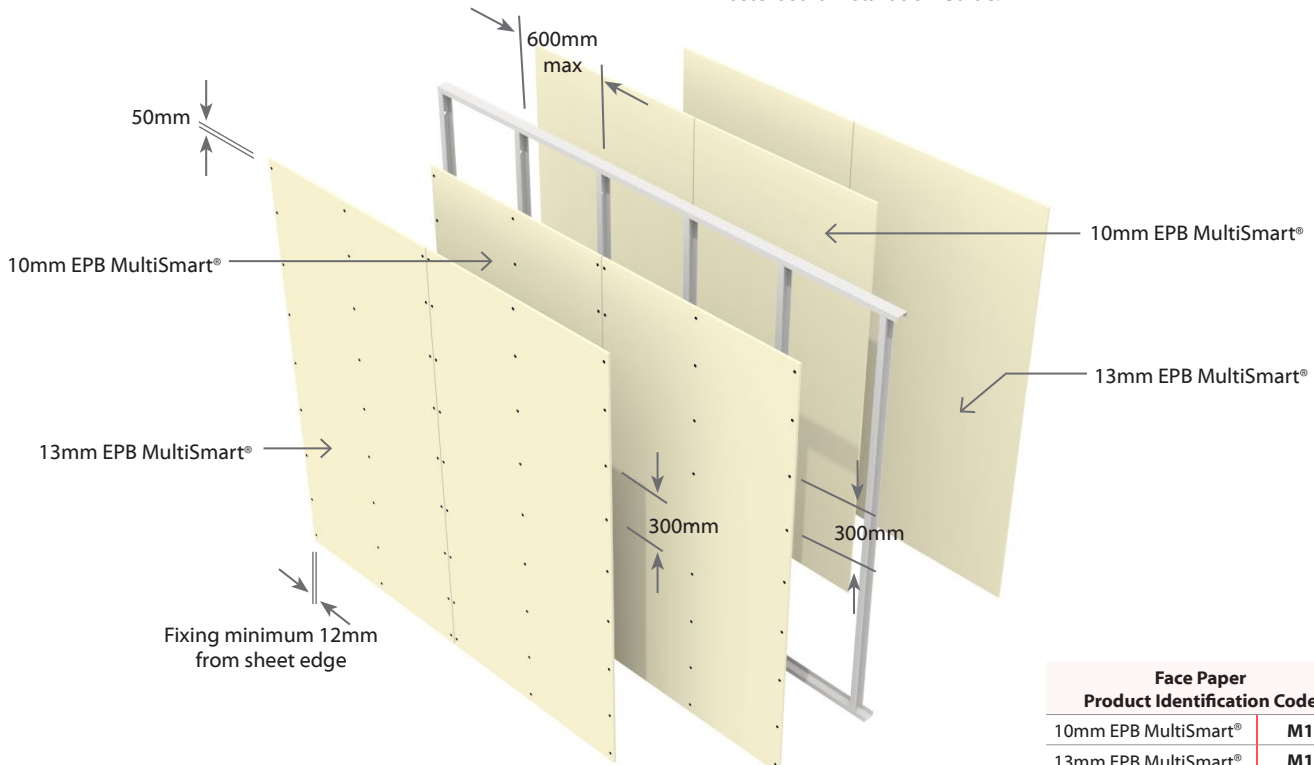

Face Paper Product Identification Code	
10mm EPB MultiSmart®	M10
13mm EPB MultiSmart®	M13



**4 Layers:** 2 Layers of Plasterboard to each side of frame

System Number	Lining Suffix	Fire Rating	Load Bearing Ability	Noise Control		Lining Requirement
				STC	Rw	
<b>E4SL90</b>	<b>-F64</b>	90/90/90	LB	47	46	2 x 16mm EPB FireSmart® on One side 2 x 16mm EPB FireSmart® to Other side

**Framing**

Any steel frame designed to meet structural criteria for strength and serviceability under dead and live loads. Stud width shall be 35mm minimum. Stud spacing at 600 centres maximum. Frame heights as determined by specific design.

**Plasterboard Lining**

**NB:** The installer must look for the Product Identification Code on the face paper to ensure the correct board type is installed. Refer to the Face Paper Product Identification Code table on this page.

Two layers of 16mm EPB FireSmart® lining on each side of the steel framing. Vertical or Horizontal fixing permitted. Use full height or full length sheets where possible.

**For Vertical Fixing-** the vertical sheet joints must be offset on the opposite side of the frame.

**For Horizontal Fixing-** the horizontal sheet joints must be formed over nogs and must be offset on the other side of the frame.

**Sheet end butt joints-** must be formed over framing and staggered. Offset joints from opposite side of the frame.

- All outer layer joints must be staggered from inner layer joints.
- All sheet joints must be formed over framing.
- The layers are fixed hard to the floor.
- Sheets shall be touch fitted.

**Fixing of Linings Fasteners**

System Number	Side One		Side Two	
	1 <sup>st</sup> Layer	2 <sup>nd</sup> Layer	1 <sup>st</sup> Layer	2 <sup>nd</sup> Layer
<b>E4SL90-F64</b>	Self-Tapping Drywall Screws			
	16mm	16mm	16mm	16mm
	32 x 6g	51 x 7g	32 x 6g	51 x 7g

**Fastener Centres**

**Inner Layer:** Fix at 600mm centres up each stud with no fixing to top and bottom track sections.

**Outer Layer:** Fix at 300mm centres up each stud with no fixing to top and bottom track sections.

Place fasteners no closer than 12mm to the sheet edge and 50mm from sheet ends.

Place fasteners at 200mm centres where sheet end butt joints occur. Avoid outer layer screws from hitting inner layer screws.

**Jointing**

**Inner Layer:** Unstopped

**Outer Layer:** All fastener heads stopped and all sheet joints reinforced with paper jointing tape and stopped. All in accordance with EPB® Plasterboard Installation Guide.

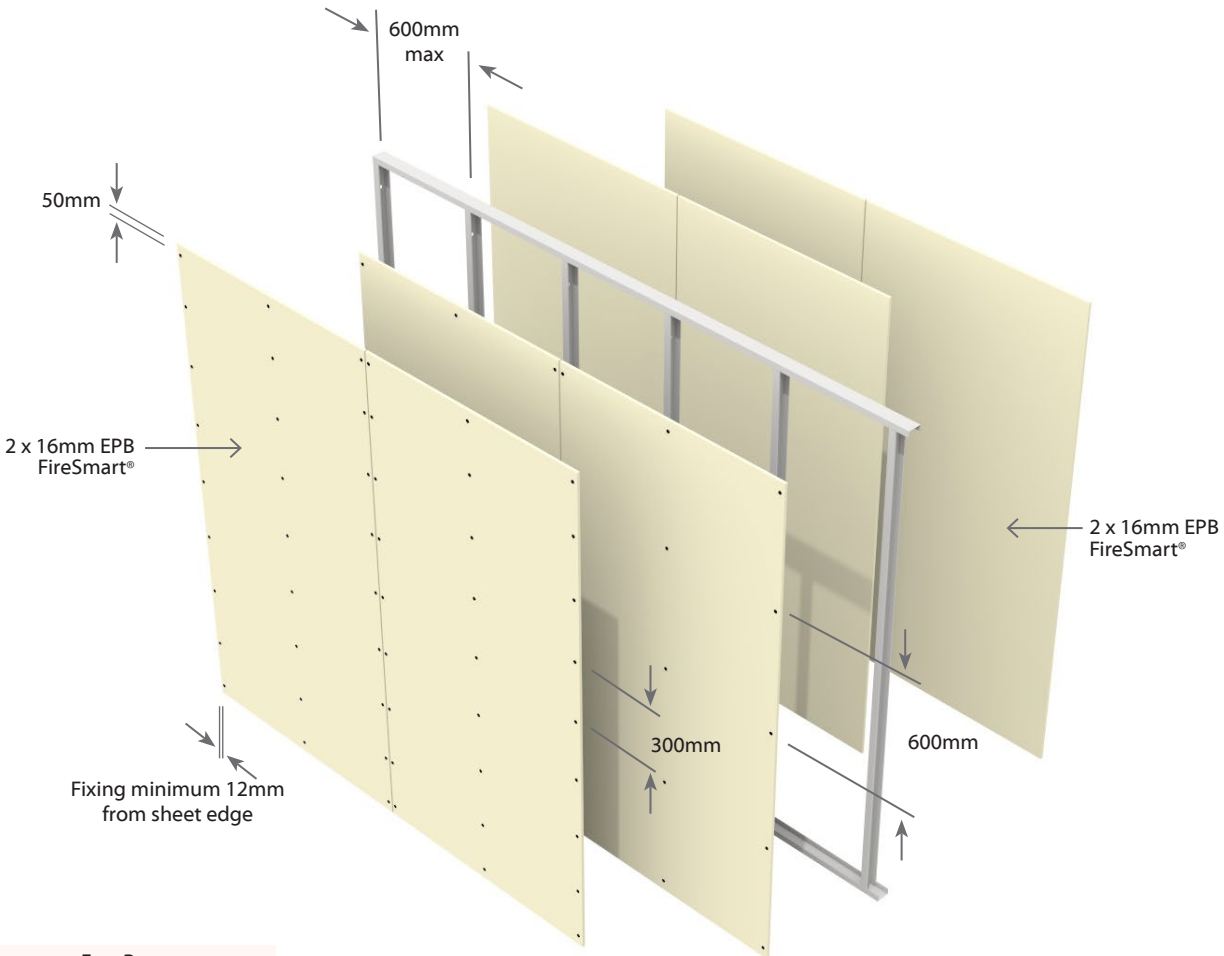

Face Paper Product Identification Code	
16mm EPB FireSmart®	<b>F16</b>



E4S120

Single Steel Frame

Non Load Bearing

Two Way FRR

4 Layers: 2 Layers of Plasterboard to each side of frame

System Number	Fire Rating	Load Bearing Ability	Noise Control		Lining Requirement
			STC	Rw	
E4S120-F52	-/120/120	NLB	45	44	2 x 13mm EPB FireSmart® on One side 2 x 13mm EPB FireSmart® to Other side
E4S120-F58	-/120/120	NLB	46	45	1 x 16mm EPB FireSmart® and 1 x 13mm EPB FireSmart® on One side 1 x 16mm EPB FireSmart® and 1 x 13mm EPB FireSmart® to Other side

E4S120-F52

**Framing**

Steel studs with minimum dimensions 92mm x 34mm x 0.75 BMT with 6mm return.

Bottom tracks to be minimum dimensions 92mm x 30mm x 0.75 BMT and Top tracks to be minimum dimensions of 92mm x 50mm x 0.75BMT.

Top & bottom tracks are fixed to the floor & ceiling in true alignment. Studs are placed at 600mm centres maximum.

Place studs to allow the nominated expansion gap (minimum 15mm) at the top of frame. The studs cannot be directly fixed to the tracks. The studs are held in place by the grip of the track runners.

**Wall Height**

Recommended maximum height is 3.0m. For higher walls refer to steel stud height table below.

Stud Dimentions (mm)	Base Metal Thickness (mm)	Stud Centres (mm)	Max Wall Heights (mm)	Expansion Tolerance at top of studs (mm)
92 x 34	0.75	600	3000	15
		400	3400	15
150 x 34	0.75	600	4400	20*
		400	5000	25*
	1.15	600	5000	25*
		400	5700	30*

E4S120-F58

**Framing**

Steel studs with minimum dimensions 64mm x 34mm x 0.50 BMT with 6mm return.

Tracks to be minimum dimensions 64mm x 30mm x 0.50 BMT.

Top & bottom tracks are fixed to the floor & ceiling in true alignment. Studs are placed at 600mm centres maximum.

Place studs to allow the nominated expansion gap (minimum 15mm) at the top of frame. The studs cannot be directly fixed to the tracks. The studs are held in place by the grip of the track runners.

**Wall Height**

Recommended maximum height is 3.0m. For higher walls refer to steel stud height table below.

Stud Dimentions (mm)	Base Metal Thickness (mm)	Stud Centres (mm)	Max Wall Heights (mm)	Expansion Tolerance at top of studs (mm)
64 x 34	0.50	600	3000	15
		400	3200	15
76 x 34	0.55	600	3200	15
		400	3800	20*
	0.75	600	3600	20*
		400	4200	20*
92 x 34	0.75	600	4200	20*
		400	4800	25*

**Plasterboard Lining**

NB: The installer must look for the Product Identification Code on the face paper to ensure the correct board type is installed. Refer to the Face Paper Product Identification Code table on this page.

Two layers of EPB FireSmart® lining on each side of the steel framing as per specified system above.

Vertical fixing only permitted. Use full height sheets where possible.

**Vertical Fixing-** the vertical sheet joints must be offset on the opposite side of the frame.

**Sheet end butt joints-** must be formed over framing and staggered. Offset joints from opposite side of the frame.

All outer layer joints must be staggered from inner layer joints.

All sheet joints must be formed over framing. The layers are fixed hard to the floor. Sheets shall be touch fitted.

**Fixing of Linings**

**Fasteners**

System Number	Side One		Side Two	
	1 <sup>st</sup> Layer	2 <sup>nd</sup> Layer	1 <sup>st</sup> Layer	2 <sup>nd</sup> Layer
	Self-Tapping Drywall Screws			
E4S120-F52	13mm	13mm	13mm	13mm
	32 x 6g	41 x 6g	32x 6g	41 x 6g
E4S120-F58	16mm	13mm	16mm	13mm
	32 x 6g	41 x 6g	32x 6g	41 x 6g

**Fastener Centres**

Inner Layer: Fix at 300mm centres up each stud with no fixing to top or bottom track sections.

Outer Layer: Fix at 300mm centres up each stud with no fixing to top and bottom track sections.

Place fasteners no closer than 12mm to the sheet edge and 50mm from sheet ends and min 20mm clear of top and bottom tracks.

Place fasteners at 200mm centres where sheet end butt joints occur. Avoid outer layer screws from hitting inner layer screws.

Fasteners may be placed at 18mm from sheet ends along top and bottom tracks, provided the fasteners do not connect the stud to the track. If floor deflections need to be considered, do not fix any linings to top track.

**Jointing**

Inner Layer: Unstopped

Outer Layer: All fastener heads stopped and all sheet joints reinforced with paper jointing tape and stopped. All in accordance with EPB® Plasterboard Installation Guide.



**E4S120**

Single Steel Frame

Non Load Bearing

Two Way FRR

**4** Layers: 2 Layers of Plasterboard to each side of frame

System Number	Fire Rating	Load Bearing Ability	Noise Control		Lining Requirement
			STC	Rw	
<b>E4S120-F52</b>	-/120/120	NLB	45	44	2 x 13mm EPB FireSmart® on One side 2 x 13mm EPB FireSmart® to Other side
<b>E4S120-F58</b>	-/120/120	NLB	46	45	1 x 16mm EPB FireSmart® and 1 x 13mm EPB FireSmart® on One side 1 x 16mm EPB FireSmart® and 1 x 13mm EPB FireSmart® to Other side

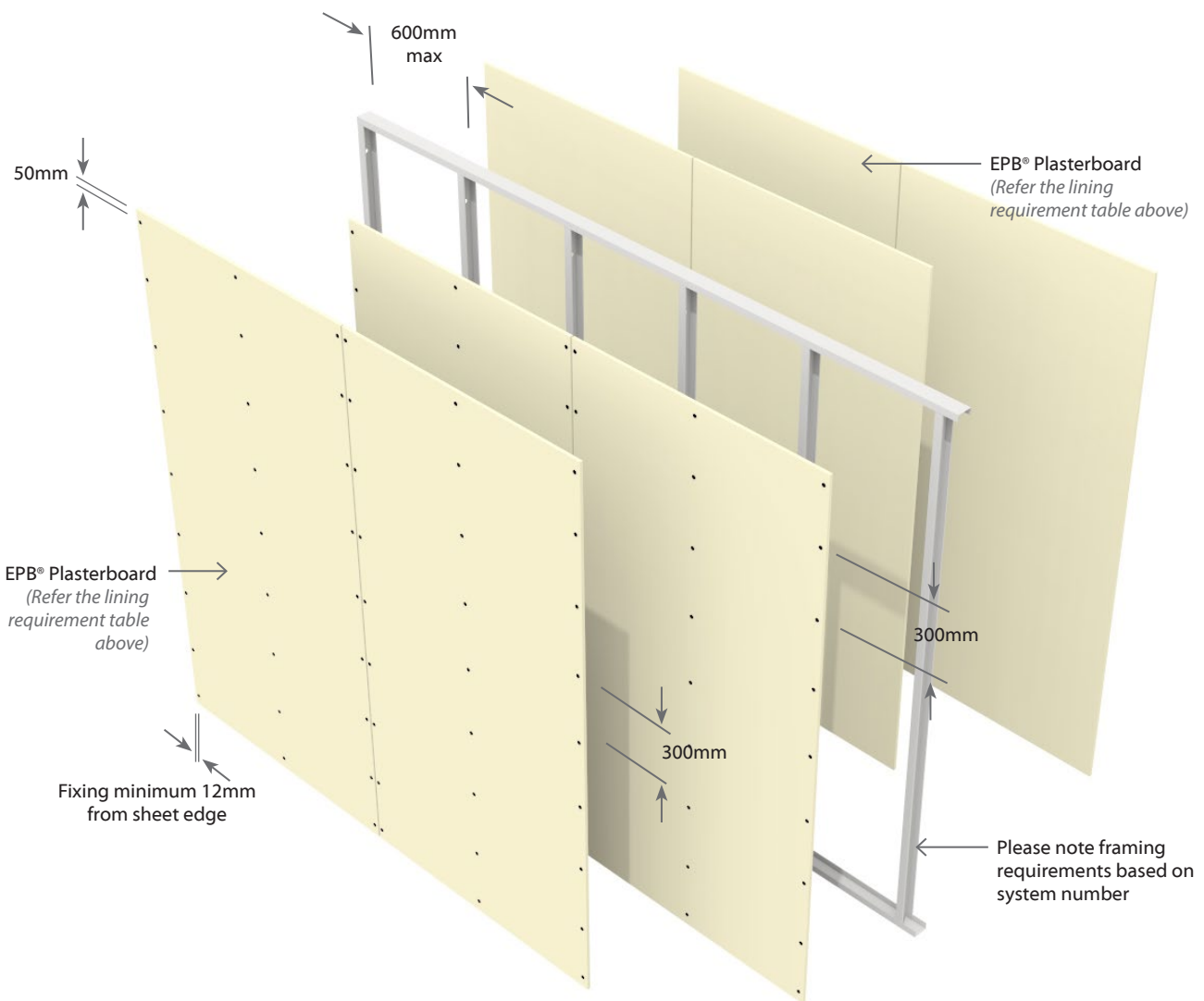

Face Paper Product Identification Code	
13mm EPB FireSmart®	<b>F13</b>
16mm EPB FireSmart®	<b>F16</b>



**E2CSD60**

**Double Steel Frame-13mm FireSmart Central liner Non Load Bearing Two Way FRR**

**2 Layers:** 1 Layer of Plasterboard to each side of frame (excludes Central liner)

System Number	Lining Suffix	Fire Rating	Load Bearing Ability	Noise Control		Lining Requirement
				STC	Rw	
<b>E2CSD60</b>	<b>-F26</b>	-/60/60	NLB	52	51	1 x 13mm EPB FireSmart® on One side 1 x 13mm EPB FireSmart® to Other side

**Framing**

Steel studs with minimum dimensions 64mm x 34mm x 0.50 BMT with 6mm return.

Tracks to be minimum size 64mm x 30mm x 0.50 BMT.

Top & bottom tracks are fixed to the floor and ceiling in true alignment.

Studs are placed at 600mm centres maximum.

Place studs to allow the nominated expansion gap (minimum 15mm) at the top of frame. The studs are not directly fixed to the tracks. The studs are held in place by the grip of the track runners.

**Wall Height**

Recommended maximum height is 3.0m. For higher walls refer to steel stud height table below.

Stud Dimensions (mm)	Base Metal Thickness (mm)	Stud Centres (mm)	Max Wall Heights (mm)	Expansion Tolerance at top of studs (mm)
<b>64 x 34</b>	0.50	600	3000	15
<b>76 x 34</b>	0.75	600	3600	20*
<b>92 x 34</b>	0.75	600	4200	20*

\* Use a minimum 50mm deep head track

**13mm FireSmart Central liner**

**NB:** The installer must look for the Product Identification Code on the face paper to ensure the correct board type is installed. Refer to the Face Paper Product Identification Code table on this page.

Fix bottom and top tracks to floor and ceiling at 600mm centres and not more than 150mm from ends using steel fasteners. Install studs at 600mm centres max.

Install 13mm EPB FireSmart® Central liner vertically at 300mm to one side using 25mm x 6g Self tapping drywall screws. Fasteners to be placed at 12mm from sheet edges and min 20mm clear of top and bottom tracks. Sheet joints to be formed over framing.

Second frame must be constructed against the 13mm EPB FireSmart® Central liner with bottom and top tracks fixed to floor and ceiling. Install studs at 600mm centres max. Offset the second frame's studs by 300mm from the first frame.

Fix the 13mm EPB FireSmart® Central liner to the second frame using 25mm x 6g Self tapping drywall screws at 300mm centres. Fasteners to be placed at 12mm from sheet edges and min 20mm clear of top and bottom tracks. Sheet joints to be formed over framing.

**Wall Sound Absorber**

Install Sound Absorber between studs on both sides of the double frame. Use 50mm thick R1.2 glass wool blanket.

**Plasterboard Lining**

**NB:** The installer must look for the Product Identification Code on the face paper to ensure the correct board type is installed. Refer to the Face Paper Product Identification Code table on this page.

One layer of 13mm EPB FireSmart® lining each side of the steel framing. Vertical fixing only permitted. Use full height sheets where possible. The vertical sheet joints must be offset on the opposite side of the frame.

**Sheet end butt joints-** must be formed over framing and staggered. Offset joints from opposite side of the frame.

All sheet joints must be formed over framing.

The layers are fixed hard to the floor. Sheets shall be touch fitted.

**Fixing of Linings**

**Fasteners**

System Number	Single Layer
	Self Tapping Drywall Screws
<b>E2CSDA60-F26</b>	13mm
	25 x 6g

**Fastener Centres**

Fix at 300mm centres up each stud with no fixing to top and bottom track sections.

Place fasteners no closer than 12mm to the sheet edge and 50mm from sheet ends and min 20mm clear of top and bottom tracks.

Place fasteners at 200mm centres where sheet end butt joints occur.

Fasteners may be placed at 18mm from sheet ends along top and bottom tracks, provided the fasteners do not connect the stud to the track.

If floor deflections need to be considered, do not fix any linings to top track.

**Penetrations**

Penetrations in cavities are permitted on either side of the Central liner for plumbing and electrical services.

Minimum 10mm clearance must be allowed between plumbing or electrical services and Central Liner for back-to-back services and penetrations.

Fire stopping for penetrations are not required for Metal and PVC Plumbing services up to 65mm diameter. 6mm max clearance gap around the plumbing services are required for penetrations through plasterboard linings. Gaps to be filled with a flexible sealant.

Penetration of electrical services up to 90 x 50mm do not require to be fire-stopped. Flush boxes are limited to two per 600mm wide stud bay.

For larger penetrations and penetrations through 13mm EPB FireSmart® Central Liner, suitable proprietary fire-stopping is required.

Penetrations through 13mm EPB FireSmart® Central Liner may reduce the STC performance.

**Plasterboard lining for Wet Area**

If 13mm EPB FireSmart® is replaced with 13mm EPB AquaSmart®, the FRR will be retained, but with a reduction in STC.

Refer to STC performance table on page 15.

**Jointing**

Central Liner: Unstopped

Outer Layers: All fastener heads stopped and all sheet joints reinforced with paper jointing tape and stopped. All in accordance with EPB® Plasterboard Installation Guide.



**E2CSD60** Double Steel Frame-13mm FireSmart Central liner Non Load Bearing Two Way FRR

2 Layers: 1 Layer of Plasterboard to each side of frame (excludes Central liner)

System Number	Lining Suffix	Fire Rating	Load Bearing Ability	Noise Control		Lining Requirement
				STC	Rw	
<b>E2CSD60</b>	<b>-F26</b>	-/60/60	NLB	52	51	1 x 13mm EPB FireSmart® on One side 1 x 13mm EPB FireSmart® to Other side

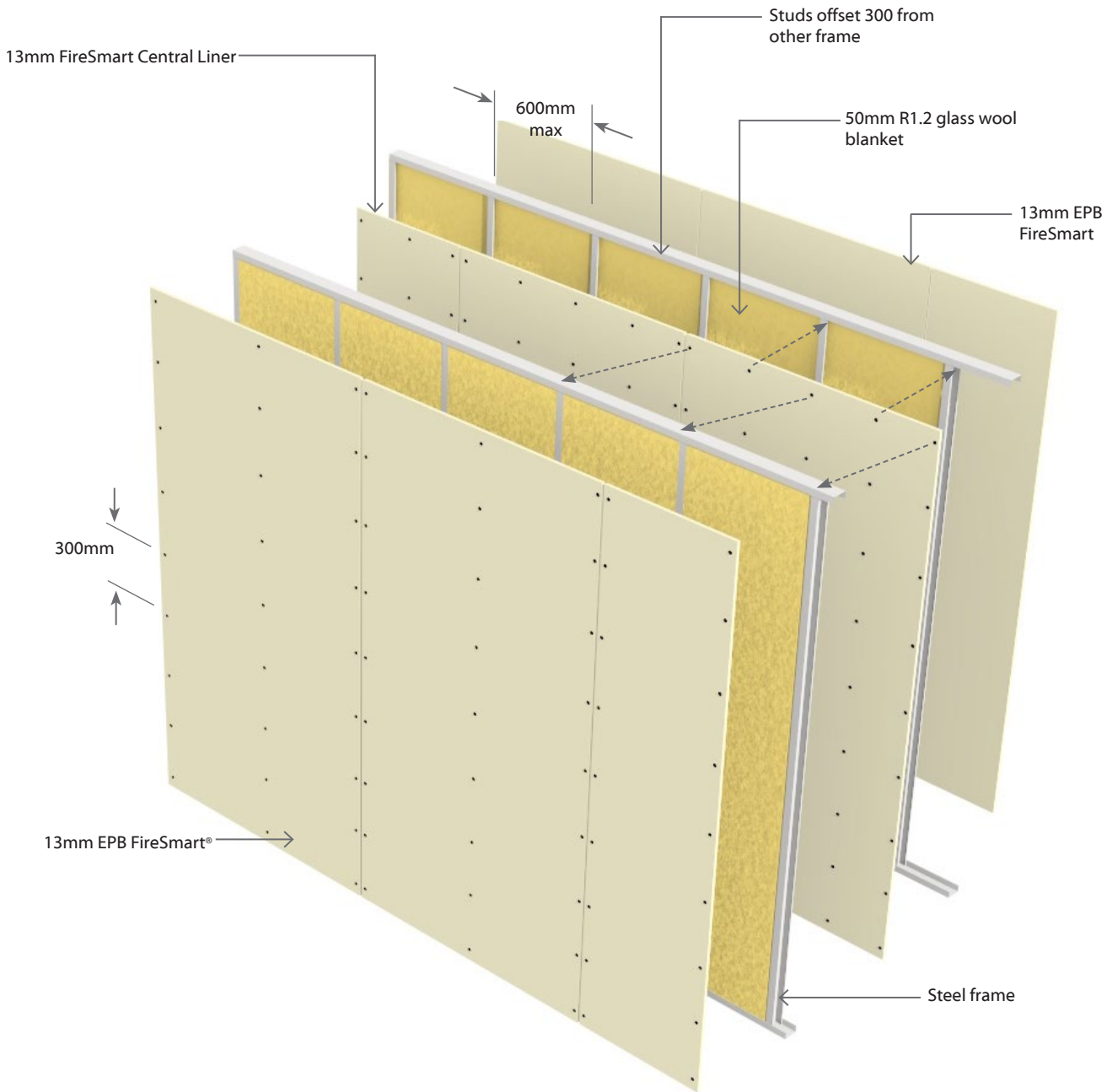

Face Paper Product Identification Code	
13mm EPB FireSmart®	<b>F13</b>





# Fire Rated Universal Walls

**E1UW15**

**Universal Timber or Steel Frame Wall**

Load Bearing

One Way FRR

**1** Layer: 1 Layer of Plasterboard to one side of frame (Fire side)

System Number	Lining Suffix	Fire Rating	Load Bearing Ability	Noise Control		Lining Requirement	Cladding (Required)
				STC	Rw		
<b>E1UW15</b>	<b>-S13</b>	15/15/15	LB	N/A	N/A	1 x 13mm EPB® Standard on One side	Any Cladding

**Framing**

Timber or Steel Frame designed to meet durability and structural criteria for strength and serviceability under dead and live loads.

Studs at 600mm centres maximum.

Stud width to be a minimum of 35mm.

Cavity depth to be a minimum of 90mm.

**Wall Height, Load and Framing Dimensions**

Timber frame : Refer to NZS3604 stud tables for height and framing dimensions of load bearing and non-load bearing partitions.

Steel frame : Refer to specific designs.

**Exterior Cladding**

The Exterior wall must be clad with a suitable weathertight material. E.g. Brick Veneer, fibre cement sheeting, timber weatherboards etc

**Plasterboard Lining (Fire side)**

**NB:** The installer must look for the Product Identification Code on the face paper to ensure the correct board type is installed. Refer to the Face Paper Product Identification Code table on this page.

One layer of 13mm EPB® Standard lining on one side of the framing. Vertical or Horizontal fixing permitted. Use full height or full length sheets where possible.

**For Horizontal Fixing-** the horizontal sheet joints must be formed over nogs.

**Sheet end butt joints-** must be formed over framing.

All sheet joints must be fixed over framing. For steel frame, linings are Cladding System fixed hard to the floor. Sheets shall be touch fitted.

**Fixing of Linings**

**Fasteners**

System Number	Timber Frame	Steel Frame
		High Thread Drywall Screws
<b>E1UW15-S13</b>	13mm	13mm
	32 x 6g	25 x 6g

**Fastener Centres**

Timber or Steel Frames: Fix at 300mm centres up each stud.

Place fasteners no closer than 12mm from sheet edges and 18mm from sheet ends.

Place fasteners at 200mm centres where sheet end butt joints occur.

**Joining**

All fastener heads stopped and all sheet joints reinforced with paper jointing tape and stopped. All in accordance with EPB® Plasterboard Installation Guide.

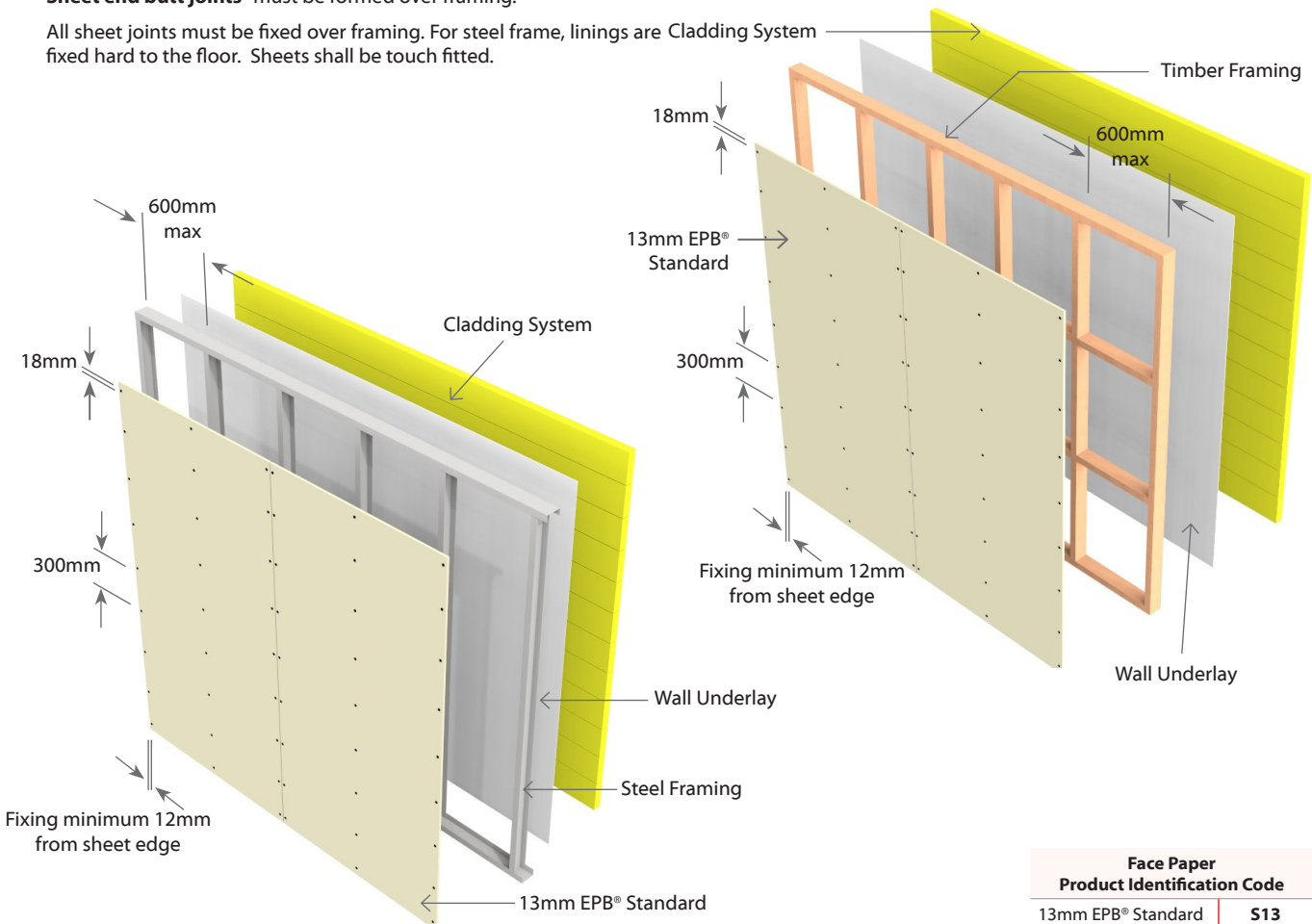

**E1UW30** Universal Timber or Steel Frame Wall Load Bearing | One Way FRR

**1** Layer: 1 Layer of Plasterboard to one side of frame (Fire side)

System Number	Lining Suffix	Fire Rating	Load Bearing Ability	Noise Control		Lining Requirement	Cladding (Required)
				STC	Rw		
<b>E1UW30</b>	<b>-F16a</b>	30/30/30**	LB	N/A	N/A	1 x 16mm EPB FireSmart® on One side	NO Polymeric foam *

\*\* N.B. System E1UW30-F16a achieves the stated fire rating with cladding systems that do not incorporate polymeric foam.  
 \* N.B. Metal cladded walls require Glasswool insulation on similar (not polyester insulation).

**Framing**

Timber or Steel Frame designed to meet durability and structural criteria for strength and serviceability under dead and live loads. Studs at 600mm centres maximum. Stud width to be a minimum of 35mm. Cavity depth to be a minimum of 90mm.

**Wall Height, Load and Framing Dimensions**

Timber frame : Refer to NZS3604 stud tables for height and framing dimensions of load bearing and non-load bearing partitions.  
 Steel frame : Refer to specific designs.

**Exterior Cladding**

The Exterior wall must be clad with a suitable weathertight material. E.g. Brick Veneer, fibre cement sheeting, timber weatherboards etc. N.B. Cladding cannot contain polymeric foam. Metal cladded walls require glass wool insulation or similar, not polyester insulation.

**Plasterboard Lining (Fire side)**

**NB:** The installer must look for the Product Identification Code on the face paper to ensure the correct board type is installed. Refer to the Face Paper Product Identification Code table on this page.

One layer of 16mm EPB FireSmart® lining on one side of the framing. Vertical or Horizontal fixing permitted. Use full height or full length sheets where possible.

**For Horizontal Fixing-** the horizontal sheet joints must be formed over noggs.

**Sheet end butt joints-** must be formed over framing.

All sheet joints must be fixed over framing. For steel frame, linings are fixed hard to the floor. Sheets shall be touch fitted.

**Fixing of Linings**

**Fasteners**

System Number	Timber Frame	Steel Frame
		High Thread Drywall Screws
<b>E1UW30-F16a</b>	16mm	16mm
	41 x 6g	32 x 6g

**Fastener Centres**

Timber Frame: Fix at 300mm centres up each stud.  
 Steel Frame: Fix at 150mm centres up sheet edges and 300mm centres up each intermediate stud.

Place fasteners 12mm from sheet edges and 18mm from sheet ends. Place fasteners at 200mm centres where sheet end butt joints occur.

**Jointing**

All fastener heads stopped and all sheet joints reinforced with paper jointing tape and stopped. All in accordance with EPB® Plasterboard Installation Guide.

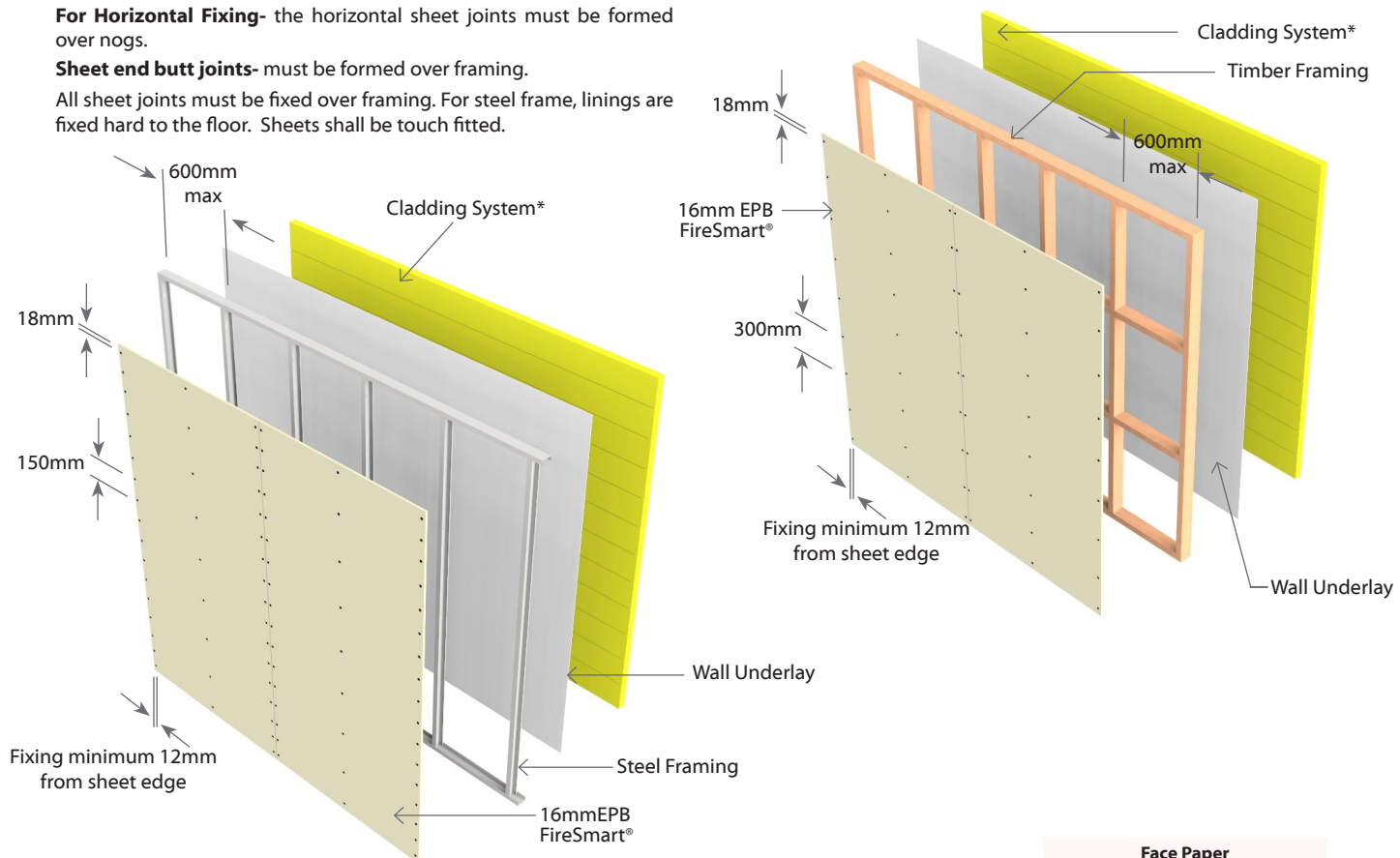

Face Paper Product Identification Code	
16mm EPB FireSmart®	<b>F16</b>

**2** Layers: 2 Layers of Plasterboard to one side of frame (Fire side)

System Number	Lining Suffix	Fire Rating	Load Bearing Ability	Noise Control		Lining Requirement	Cladding (Required)
				STC	Rw		
E2UW30	-F20	30/30/30	LB	N/A	N/A	2 x 10mm EPB FireSmart® on One side	Any Cladding

**Framing**

Timber or Steel Frame designed to meet durability and structural criteria for strength and serviceability under dead and live loads. Studs at 600mm centres maximum. Stud width to be a minimum of 35mm. Cavity depth to be a minimum of 90mm.

**Wall Height, Load and Framing Dimensions**

Timber frame : Refer to NZS3604 stud tables for height and framing dimensions of load bearing and non-load bearing partitions. Steel frame : Refer to specific designs.

**Exterior Cladding**

The Exterior wall must be clad with a suitable weathertight material. E.g. Brick Veneer, fibre cement sheeting, timber weatherboards etc.

**Plasterboard Lining (Fire side)**

**NB:** The installer must look for the Product Identification Code on the face paper to ensure the correct board type is installed. Refer to the Face Paper Product Identification Code table on this page.

Two layers of 10mm EPB FireSmart® Plasterboard lining as per specified system above on one side of the framing.

Vertical or Horizontal fixing permitted. Use full height or full length sheets where possible. All outer layer joints must be staggered from inner layer joints.

**Inner layer:** All vertical or horizontal sheet joints of the inner layer must be formed over framing.

**Outer layer(vertical fixing):** All sheet joints must be fixed over framing. All vertical sheet joints must be fixed over framing. Sheet end butt joints do not need to be formed over framing but must be offset from inner layer

**Outer layer(horizontal fixing):** All sheet joints must be fixed over framing except longitudinal sheet joints of the outer layer, which do not need to be formed over framing. Sheet end butt joints must be formed over framing.

For steel frame, linings are fixed hard to the floor. Sheets shall be touch fitted.

**Fixing of Linings**

**Fasteners**

System Number	Timber Frame		Steel Frame	
	1 <sup>st</sup> Layer	2 <sup>nd</sup> Layer	1 <sup>st</sup> Layer	2 <sup>nd</sup> Layer
	High Thread Drywall Screws		Self-Tapping Drywall Screws	
E2UW30-F20	10mm	10mm	10mm	10mm
	41 x 6g	51 x 7g	25 x 6g	32 x 6g

**Fastener Centres**

Inner Layer: Fix at 300mm centres up each stud.

Outer Layer: Fix at 300mm centres up each stud.

Place fasteners no closer than 12mm from sheet edges and 18mm from sheet ends.

Place fasteners at 200mm centres where sheet end butt joints occur.

Avoid outer layer screws from hitting inner layer screws.

**Jointing**

Inner Layer: Unstopped.

Outer Layer: All fastener heads stopped and all sheet joints reinforced and stopped. All in accordance with EPB® Plasterboard Installation Guide.

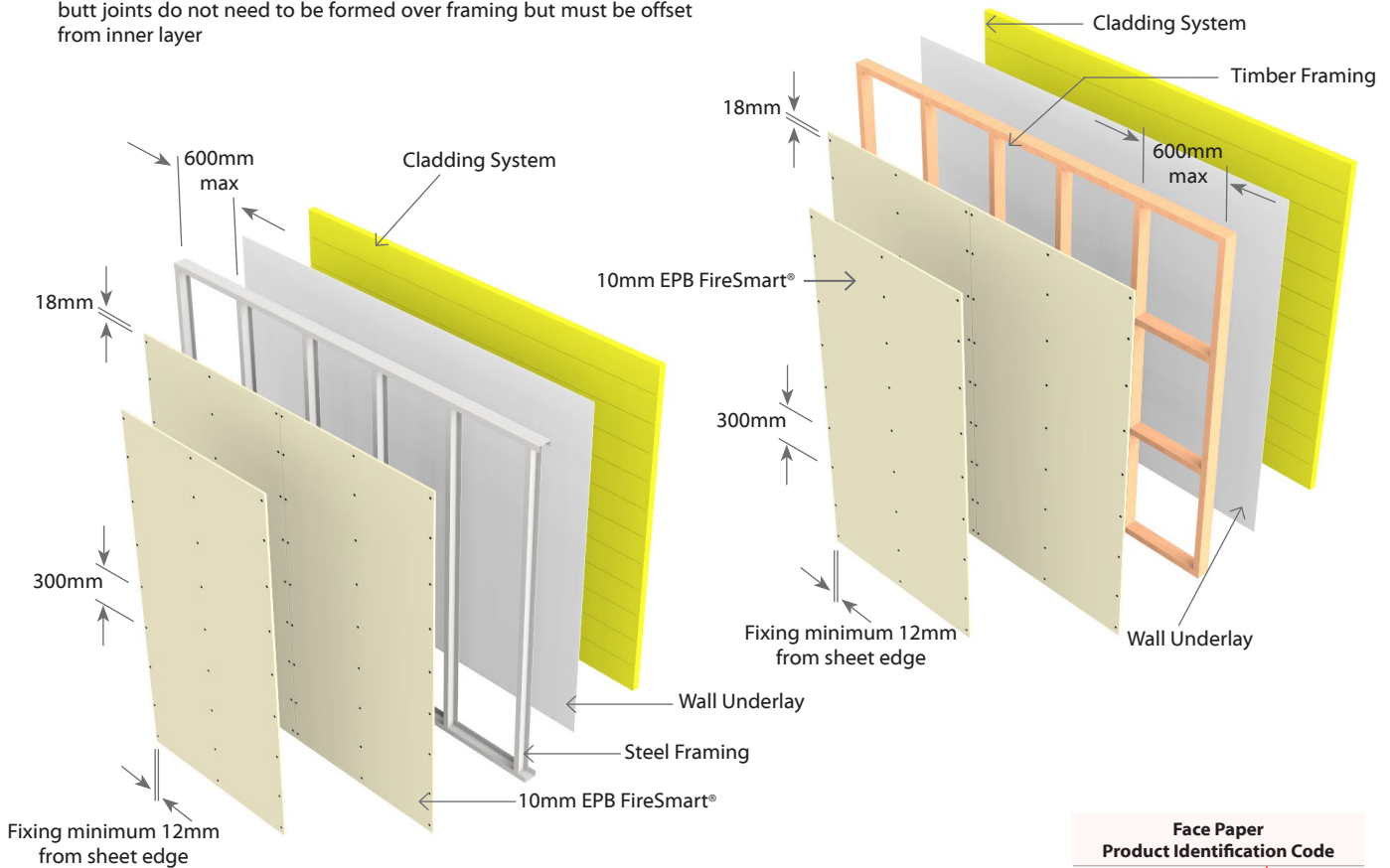

Face Paper Product Identification Code	
10mm EPB FireSmart®	F10



**2 Layers:** 2 Layers of Plasterboard to one side of frame (Fire side)

System Number	Lining Suffix	Fire Rating	Load Bearing Ability	Noise Control		Lining Requirement	Cladding (Required)
				STC	Rw		
<b>E2UW45</b>	<b>-F26</b>	45/45/45	LB	N/A	N/A	2 x 13mm EPB FireSmart® on One side	Any Cladding

**Framing**

Timber or Steel Frame designed to meet durability and structural criteria for strength and serviceability under dead and live loads. Studs at 600mm centres maximum. Stud width to be a minimum of 35mm. Cavity depth to be a minimum of 90mm.

**Wall Height , Load and Framing Dimensions**

Timber frame : Refer to NZS3604 stud tables for height and framing dimensions of load bearing and non-load bearing partitions. Steel frame : Refer to specific designs.

**Exterior Cladding**

The Exterior wall must be clad with a suitable weathertight material. E.g. Brick Veneer, fibre cement sheeting, timber weatherboards etc.

**Plasterboard Lining (Fire side)**

**NB:** The installer must look for the Product Identification Code on the face paper to ensure the correct board type is installed. Refer to the Face Paper Product Identification Code table on this page.

Two layers of 13mm EPB FireSmart® lining on one side of the framing. Vertical or Horizontal fixing permitted. Use full height or full length sheets where possible. All outer layer joints must be staggered from inner layer joints.

**Inner layer:** All vertical or horizontal sheet joints of the inner layer must be formed over framing.

**Outer layer(vertical fixing):** All sheet joints must be fixed over framing. All vertical sheet joints must be fixed over framing. Sheet end butt joints do not need to be formed over framing but must be offset from inner layer

**Outer layer(horizontal fixing):** All sheet joints must be fixed over framing except longitudinal sheet joints of the outer layer, which do not need to be formed over framing. Sheet end butt joints must be formed over framing.

For steel frame, linings are fixed hard to the floor. Sheets shall be touch fitted.

**Fixing of Linings**

**Fasteners**

System Number	Timber Frame		Steel Frame	
	1 <sup>st</sup> Layer	2 <sup>nd</sup> Layer	1 <sup>st</sup> Layer	2 <sup>nd</sup> Layer
	High Thread Drywall Screws		Self-Tapping Drywall Screws	
<b>E2UW45-F26</b>	13mm	13mm	13mm	13mm
	32 x 6g	51 x 7g	25 x 6g	41 x 6g

**Fastener Centres**

Inner Layer: Fix at 300mm centres up each stud.  
Outer Layer: Fix at 300mm centres up each stud.  
Place fasteners no closer than 12mm from sheet edges and 18mm from sheet ends.  
Place fasteners at 200mm centres where sheet end butt joints occur. Avoid outer layer screws from hitting inner layer screws.

**Jointing**

Inner Layer: Unstopped.  
Outer Layer: All fastener heads stopped and all sheet joints reinforced and stopped. All in accordance with EPB® Plasterboard Installation Guide.

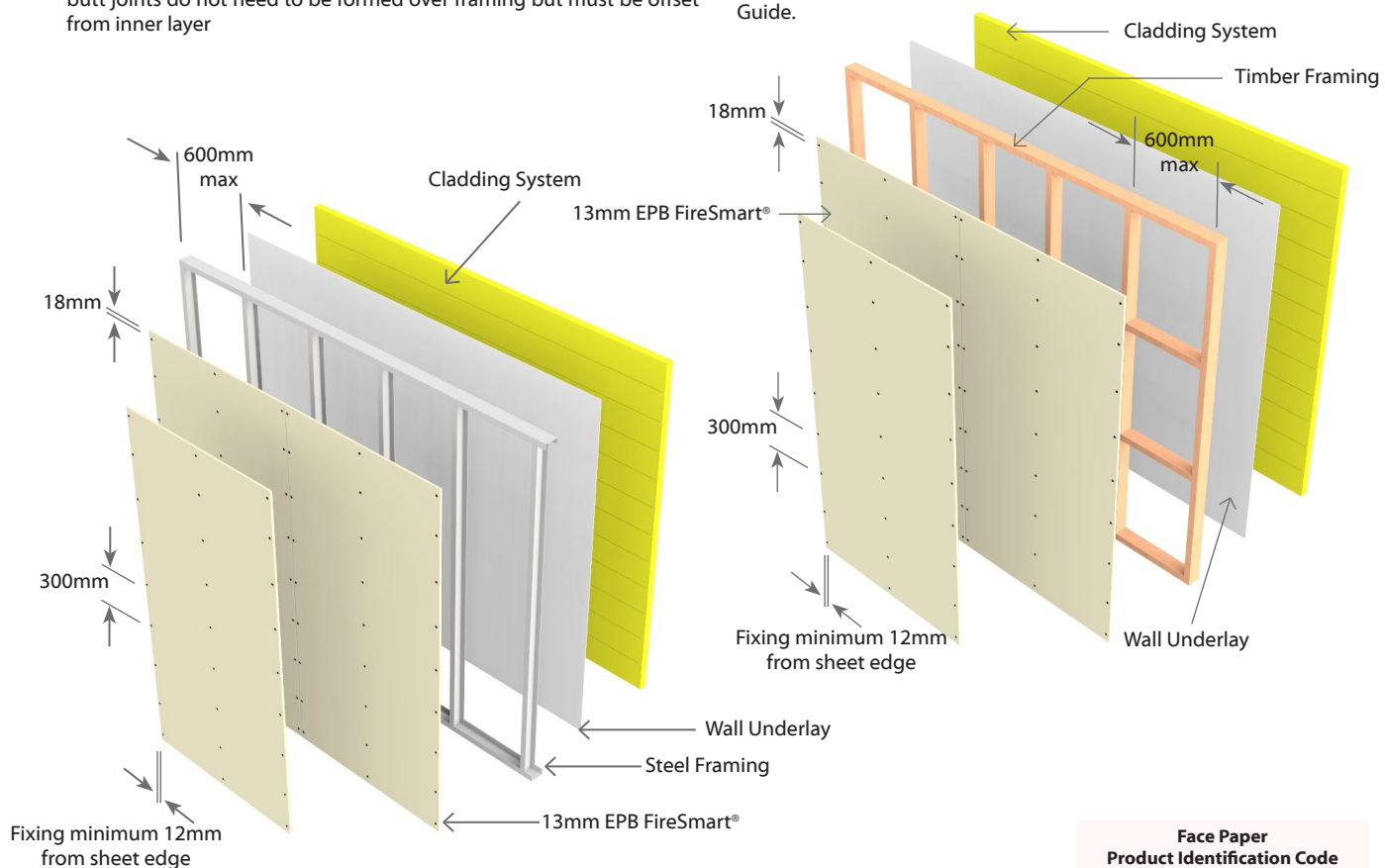

Face Paper Product Identification Code	
13mm EPB FireSmart®	<b>F13</b>



**2** Layers: 2 Layers of Plasterboard to one side of frame (Fire side)

System Number	Lining Suffix	Fire Rating	Load Bearing Ability	Noise Control		Lining Requirement	Cladding (Required)
				STC	Rw		
E2UW60	-F26a	60/60/60**	LB	N/A	N/A	2 x 13mm EPB FireSmart® on One side	NO Polymeric foam
	-F29	60/60/60	LB	N/A	N/A	1 x 13mm EPB FireSmart® and 1 x 16mm EPB FireSmart® on One side	Any Cladding

\*\* N.B. System E2UW60-F26a achieves the stated fire rating with cladding systems that do not incorporate polymeric foam

**Framing**

Timber or Steel Frame designed to meet durability and structural criteria for strength and serviceability under dead and live loads. Studs at 600mm centres maximum. Stud width to be a minimum of 35mm. Cavity depth to be a minimum of 90mm.

**Wall Height, Load and Framing Dimensions**

Timber frame : Refer to NZS3604 stud tables for height and framing dimensions of load bearing and non-load bearing partitions.  
Steel frame : Refer to specific designs.

**Exterior Cladding**

Exterior walls must be clad with a suitable weathertight material. E.g. Brick Veneer, fibre cement sheeting, timber weatherboards etc.

N.B. Cladding cannot contain polymeric foam for system E2UW60-M26a & E2UW60-MF26a.

**Plasterboard Lining (Fire side)**

**NB:** The installer must look for the Product Identification Code on the face paper to ensure the correct board type is installed. Refer to the Face Paper Product Identification Code table on this page.

Two layers of EPB® Plasterboard lining as per specified system above on one side of the framing.

Vertical or Horizontal fixing permitted. Use full height or full length sheets where possible. All vertical joints of the inner layer must be formed over framing. All outer layer joints must be offset from inner layer joints. For steel frame, linings are fixed hard to the floor. Sheets shall be touch fitted.

**E2UW60-F26a:**

Where sheet end butt joints are unavoidable, the inner layer joints must be formed over nogs. Stagger the outer layer butt joints from the inner layer by minimum 100mm.

**E2UW60-F29:**

Sheet end butt joints do not need to be formed over nogs. Stagger the outer layer butt joints from the inner layer by minimum 100mm.

**Fixing of Linings**

Fasteners (As per Specified System Above)

System Number	Timber Frame		Steel Frame	
	1 <sup>st</sup> Layer	2 <sup>nd</sup> Layer	1 <sup>st</sup> Layer	2 <sup>nd</sup> Layer
	High Thread Drywall Screws		Self-Tapping Drywall Screws	
E2UW60-M26a	13mm	13mm	13mm	13mm
	32 x 6g	51 x 7g	25 x 6g	41 x 6g
E2UW60-F29	13mm	16mm	13mm	16mm
	32 x 6g	51 x 7g	32 x 6g	51 x 7g

**Fastener Centres**

Inner Layer: Fix at 300mm centres up each stud.

Outer Layer: Fix at 300mm centres up each stud.

Place fasteners no closer than 12mm from sheet edges and 18mm from sheet ends.

Place fasteners at 200mm centres where sheet end butt joints occur.

Avoid outer layer screws from hitting inner layer screws.

**Jointing**

Inner Layer: Unstopped.

Outer Layer: All fastener heads stopped and all sheet joints reinforced and stopped. All in accordance with EPB® Plasterboard Installation Guide.

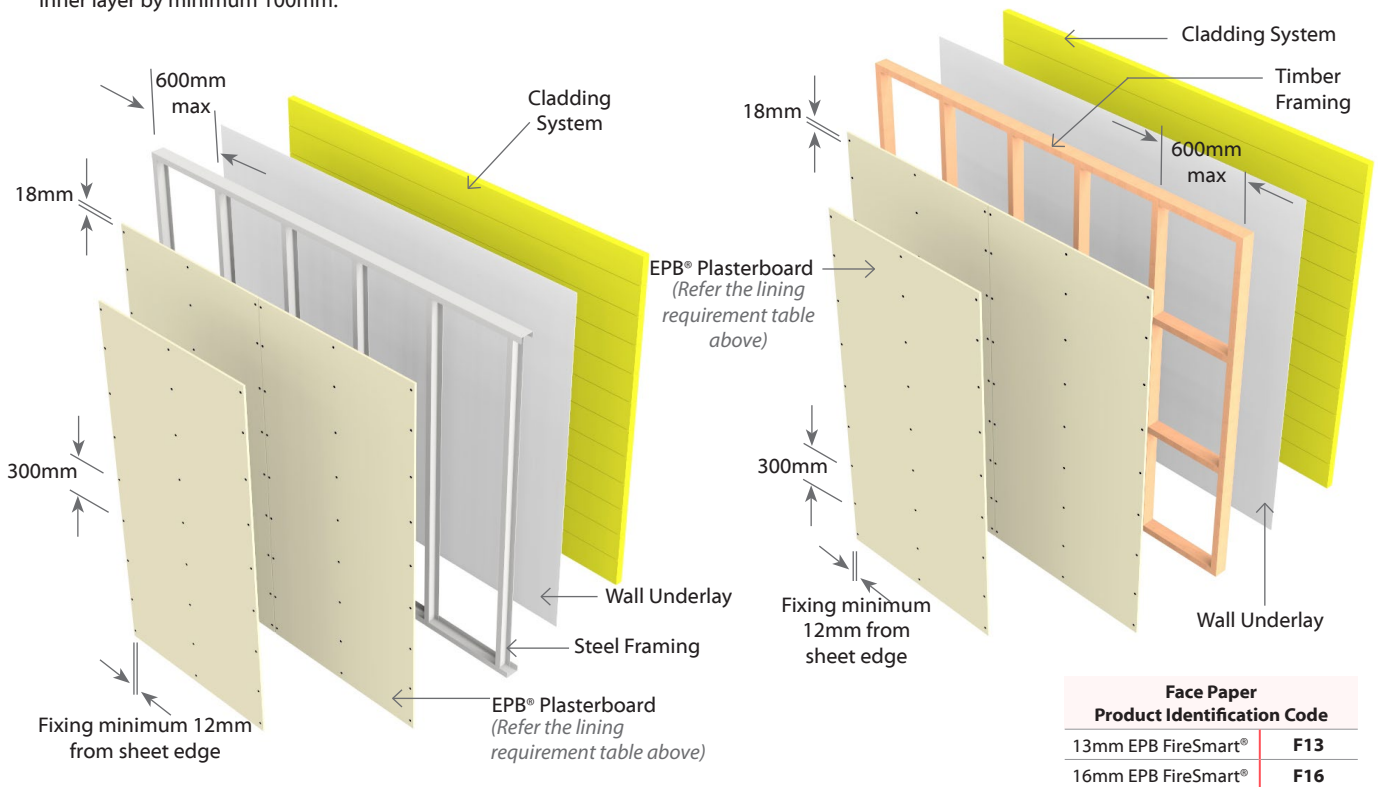

**3 Layers: 3 Layers of Plasterboard to one side of frame (Fire side)**

System Number	Lining Suffix	Fire Rating	Load Bearing Ability	Noise Control		Lining Requirement	Cladding (Required)
				STC	Rw		
E3UW90	-F39a	90/90/90**	LB	N/A	N/A	3 x 13mm EPB FireSmart® on One side	NO Polymeric foam
	-F42	90/90/90	LB	N/A	N/A	1 x 16mm EPB FireSmart® and 2 x 13mm EPB FireSmart® on One side	Any Cladding

\*\* N.B. System E3UW90-F39a achieves the stated fire rating with cladding systems that do not incorporate polymeric foam

**Framing**

Timber or Steel Frame designed to meet durability and structural criteria for strength and serviceability under dead and live loads.

Studs at 600mm centres maximum.

Stud width to be a minimum of 35mm.

Cavity depth to be a minimum of 90mm.

**Wall Height, Load and Framing Dimensions**

Timber frame : Refer to NZS3604 stud tables for height and framing dimensions of load bearing and non-load bearing partitions.

Steel frame : Refer to specific designs.

**Exterior Cladding**

The Exterior wall must be clad with a suitable weathertight material. E.g. Brick Veneer, fibre cement sheeting, timber weatherboards etc.

N.B. Cladding cannot contain polymeric foam for system E2UW90-F39a.

**Plasterboard Lining (Fire side)**

**NB:** The installer must look for the Product Identification Code on the face paper to ensure the correct board type is installed. Refer to the Face Paper Product Identification Code table on this page.

Three layers of EPB® Plasterboard lining as per specified system above on one side of the framing.

Vertical or Horizontal fixing permitted. Use full height or full length sheets where possible.

**Inner layer:** The vertical or horizontal sheet joints of the inner layer must be formed over framing.

**Outer layer(vertical fixing):** All sheet joints must be fixed over framing.

**Outer layer(horizontal fixing):** All sheet joints must be fixed over framing except longitudinal sheet joints of the outer layer, which do not need to be formed over framing.

Sheet end butt joints must be formed over framing. All outer layer joints must be staggered from inner layer joints. For steel frame, linings are fixed hard to the floor. Sheets shall be touch fitted.

**Fixing of Linings**

**Fasteners (As per Specified System Above)**

System Number	Timber Frame			Steel Frame		
	1 <sup>st</sup> Layer	2 <sup>nd</sup> Layer	3 <sup>rd</sup> Layer	1 <sup>st</sup> Layer	2 <sup>nd</sup> Layer	3 <sup>rd</sup> Layer
	High Thread Drywall Screws			Self-Tapping Drywall Screws		
E3UW90-F39a	13mm	13mm	13mm	13mm	13mm	13mm
	41 x 6g	51 x 7g	63 x 8g	25 x 6g	41 x 6g	51 x 7g
E3UW90-F42	16mm	13mm	13mm	16mm	13mm	13mm
	41 x 6g	51 x 7g	63 x 8g	32 x 6g	41 x 6g	63 x 8g

**Fastener Centres**

First and Second Layer: Fix at 300mm centres up each stud.

Outer Layer: Fix at 300mm centres up each stud.

Place fasteners no closer than 12mm from sheet edges and 18mm from sheet ends..

Place fasteners at 200mm centres where sheet end butt joints occur.

Avoid outer layer screws from hitting inner layer screws.

**Jointing**

1st and 2nd Layers: Unstopped

Outer Layer: All fastener heads stopped and all sheet joints reinforced and stopped. All in accordance with EPB® Plasterboard Installation Guide.

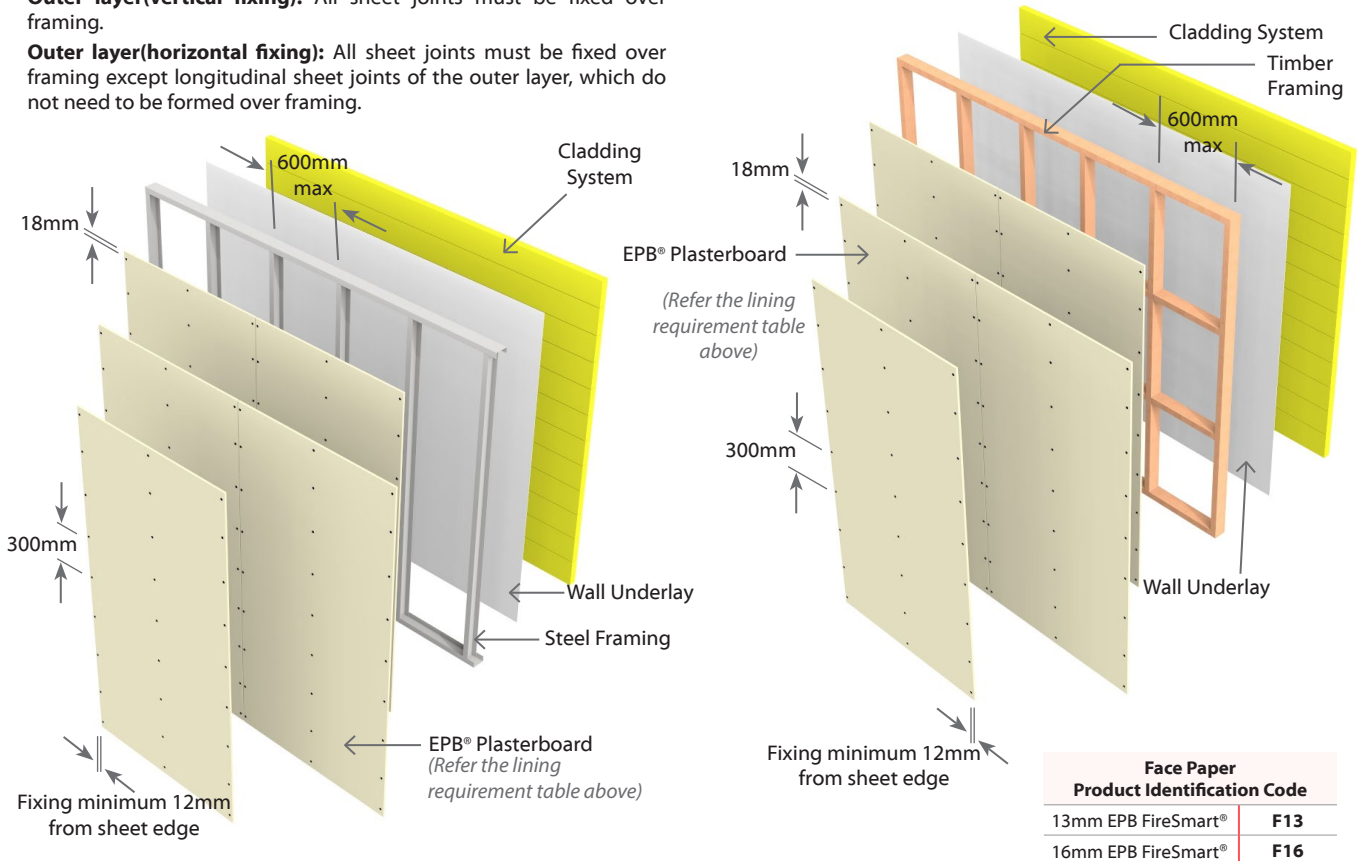

**3** Layers: 3 Layers of Plasterboard to one side of frame (Fire side)

System Number	Lining Suffix	Fire Rating	Load Bearing Ability	Noise Control		Lining Requirement	Cladding (Required)
				STC	Rw		
<b>E3UW120</b>	<b>-F45a</b>	120/120/120**	LB	N/A	N/A	1 x 13mm EPB FireSmart® and 2 x 16mm EPB FireSmart® on One Side	NO Polymeric foam

\*\* N.B. System E3UW120-F45a achieves the stated fire rating with cladding systems that do not incorporate polymeric foam

**Framing**

Timber or Steel Frame designed to meet durability and structural criteria for strength and serviceability under dead and live loads.

Studs at 600mm centres maximum.

Stud width to be a minimum of 35mm.

Cavity depth to be a minimum of 90mm.

**Wall Height, Load and Framing Dimensions**

Timber frame : Refer to NZS3604 stud tables for height and framing dimensions of load bearing and non-load bearing partitions.

Steel frame : Refer to specific designs.

**Exterior Cladding**

The Exterior wall must be clad with a suitable weathertight material. E.g. Brick Veneer, fibre cement sheeting, timber weatherboards etc.

N.B. Cladding cannot contain polymeric foam .

**Plasterboard Lining (Fire side)**

**NB:** The installer must look for the Product Identification Code on the face paper to ensure the correct board type is installed. Refer to the Face Paper Product Identification Code table on this page.

One layer of 13mm EPB FireSmart® and Two layers of 16mm EPB FireSmart® lining on one side of the framing.

Vertical or Horizontal fixing permitted. Use full height or full length sheets where possible.

**Inner layer:** The vertical or horizontal sheet joints of the inner layer must be formed over framing.

**Outer layer(vertical fixing):** All sheet joints must be fixed over framing.

**Outer layer(horizontal fixing):** All sheet joints must be fixed over framing except longitudinal sheet joints of the outer layer, which do not need to be formed over framing.

Sheet end butt joints must be formed over framing. All outer layer joints must be staggered from inner layer joints. For steel frame, linings are fixed hard to the floor. Sheets shall be touch fitted.

**Fixing of Linings**

**Fasteners**

System Number	Timber Frame			Steel Frame		
	1 <sup>st</sup> Layer	2 <sup>nd</sup> Layer	3 <sup>rd</sup> Layer	1 <sup>st</sup> Layer	2 <sup>nd</sup> Layer	3 <sup>rd</sup> Layer
	High Thread Drywall Screws			Self-Tapping Drywall Screws		
<b>E3UW120-F45a</b>	13mm	16mm	16mm	13mm	16mm	16mm
	32 x 6g	51 x 7g	63 x 8g	25x 6g	41 x 7g	63 x 8g

**Fastener Centres**

First and Second Layer: Fix at 300mm centres up each stud.

Outer Layer: Fix at 300mm centres up each stud.

Place fasteners no closer than 12mm from sheet edges and 18mm from sheet ends.

Place fasteners at 200mm centres where sheet end butt joints occur.

Avoid outer layer screws from hitting inner layer screws.

**Jointing**

1st and 2nd Layers: Unstopped

Outer Layer: All fastener heads stopped and all sheet joints reinforced and stopped. All in accordance with EPB® Plasterboard Installation Guide.

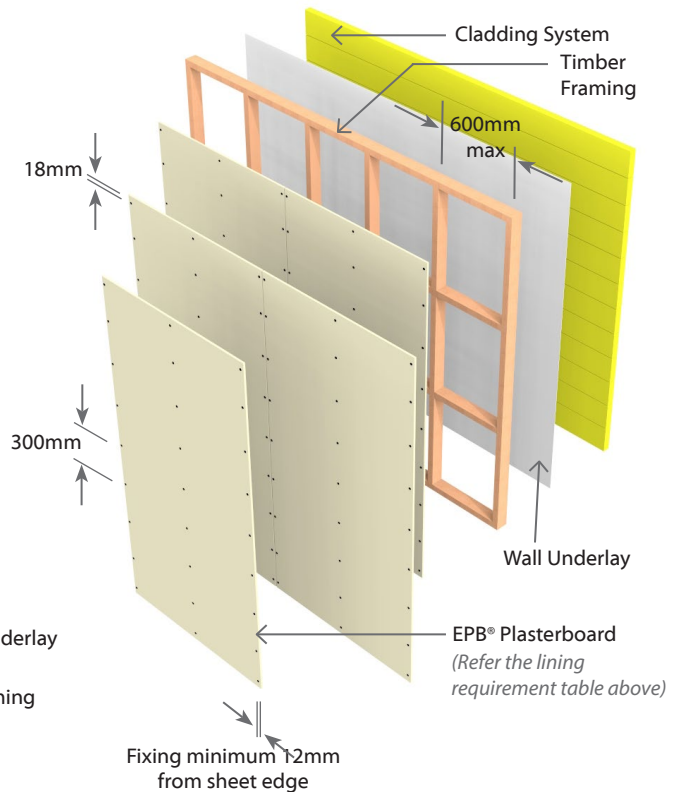
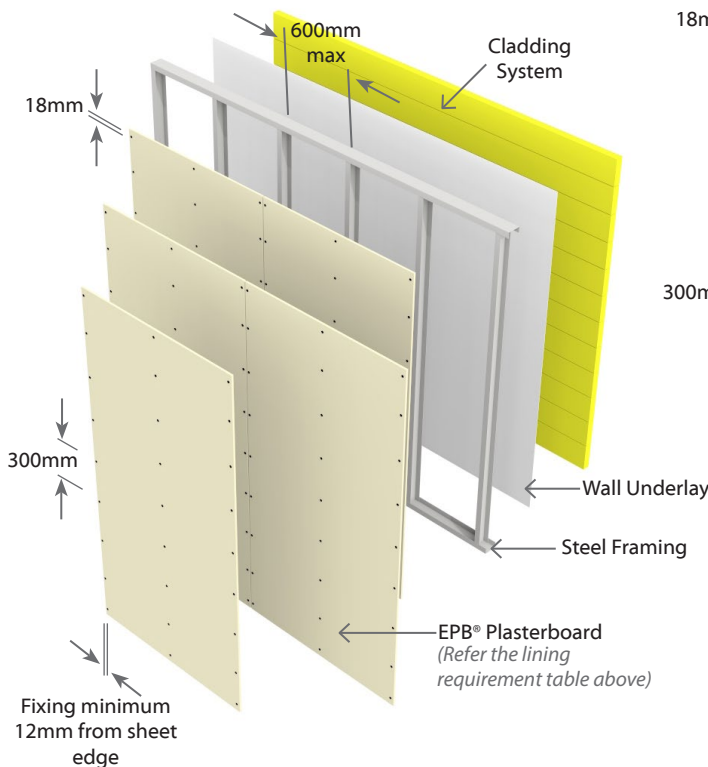

Face Paper Product Identification Code	
13mm EPB FireSmart®	<b>F13</b>
16mm EPB FireSmart®	<b>F16</b>



**E2TL30S**

Single Timber Frame Wall with Simultaneous Fire Exposure on Both sides

Load Bearing

Simultaneous

**2** Layers: 1 Layer of Plasterboard to each side of frame

System Number	Lining Suffix	Fire Rating	Load Bearing Ability	Noise Control		Lining Requirement
				STC	Rw	
E2TL30S	-F26	30/-/-	LB	38	37	1 x 13mm EPB FireSmart® on One Side 1 x 13mm EPB FireSmart® to Other Side

**Framing**

Framing to comply with relevant sections and clauses of NZBC B1: Structure and NZBC B2: Durability.

Studs at 600mm centres maximum.

Nogs at 1000mm centre maximum.

**Wall Height, Load and Framing Dimensions**

These are determined by NZS3604 stud tables for load bearing or non-load bearing partitions.

**Plasterboard Lining**

**NB:** The installer must look for the Product Identification Code on the face paper to ensure the correct board type is installed. Refer to the Face Paper Product Identification Code table on this page.

One layer of 13mm EPB FireSmart® lining on each side of the timber framing. Vertical or Horizontal fixing permitted. Use full height or full length sheets where possible.

**For Vertical Fixing-** the vertical sheet joints must be offset on the opposite side of the frame.

**For Horizontal Fixing-** the horizontal sheet joints on the opposite side of the frame can be formed over the same row of nogs.

**Sheet end butt joints-** must be formed over framing, offset from opposite side of the frame.

All sheet joints must be fixed over solid timber framing.

Sheets shall be touch fitted.

**Fixing of Linings**

**Fasteners**

System Number	Side One	Side Two
	High Thread Drywall Screws	
E2TL30S-F26	13mm	13mm
	41 x 6g	41 x 6g

**Fastener Centres**

Fix at 300mm centres at sheet perimeters and on top and bottom plates. And 300mm centres up all studs.

Place fasteners 50mm from sheet corners along the top and bottom plates. On end studs place additional fasteners 50-60mm vertically and no close than 10mm from plate to stud connections.

Place fasteners no closer than 12mm from the sheet edges and 18mm from sheet ends.

Place fasteners at 200mm centres where sheet end butt joints occur.

**Jointing**

All fastener heads stopped and all sheet joints reinforced with paper jointing tape and stopped. All in accordance with EPB® Plasterboard Installation Guide.

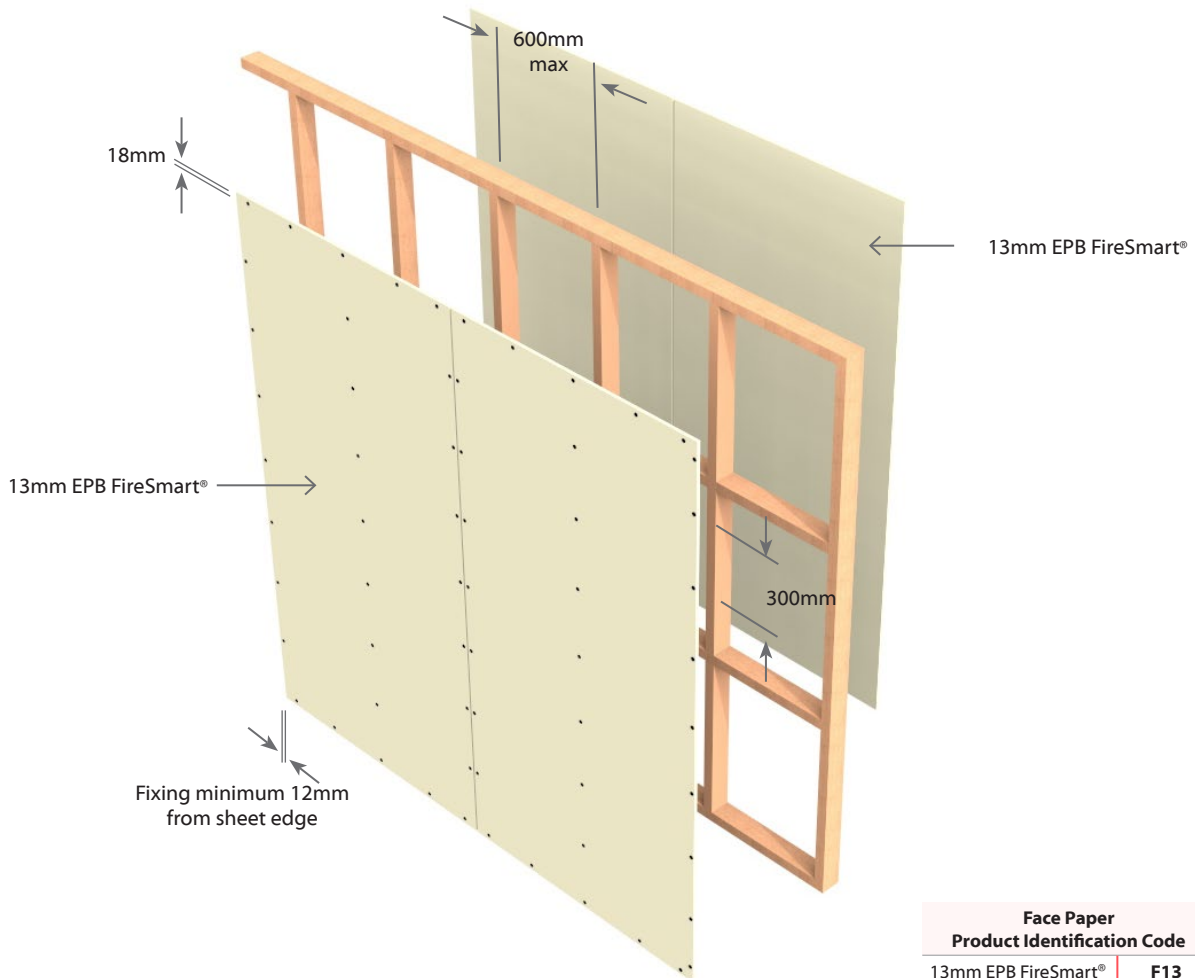

**E4TL60S**

Single Timber Frame Wall with Simultaneous Fire Exposure on Both sides

Load Bearing

Simultaneous

4 Layers: 2 Layers of Plasterboard to each side of frame

System Number	Lining Suffix	Fire Rating	Load Bearing Ability	Noise Control		Lining Requirement
				STC	Rw	
E4TL60S	-F52	60/-/-	LB	46	45	2 x 13mm EPB FireSmart® on One Side 2 x 13mm EPB FireSmart® to Other Side

**Framing**

Framing to comply with relevant sections and clauses of NZBC B1: Structure and NZBC B2: Durability.  
Studs at 600mm centres maximum.  
Nogs at 1000mm centre maximum.

**Wall Height, Load and Framing Dimensions**

These are determined by NZS3604 stud tables for load bearing or non-load bearing partitions.

**Plasterboard Lining**

**NB:** The installer must look for the Product Identification Code on the face paper to ensure the correct board type is installed. Refer to the Face Paper Product Identification Code table on this page.

Two layers of 13mm EPB FireSmart® lining on each side of the timber framing. Vertical or Horizontal fixing permitted. Use full height or full length sheets where possible.

**For Vertical Fixing-** the vertical sheet joints must be offset on the opposite side of the frame and staggered between layers.

**For Horizontal Fixing-** the horizontal sheet joints on the opposite side of the frame can be formed over the same row of nogs and must be staggered between layers.

Optionally, inner layers can be fixed vertically and outer layers fixed horizontally.

**Sheet end butt joints-** must be formed over framing, offset from opposite side of the frame and staggered between layers.

All sheet joints must be fixed over solid timber framing. Sheets shall be touch fitted.

**Fixing of Linings**

**Fasteners**

System Number	Side One		Side Two	
	1 <sup>st</sup> Layer	2 <sup>nd</sup> Layer	1 <sup>st</sup> Layer	2 <sup>nd</sup> Layer
	High Thread Drywall Screws			
E4TL60S-F52	13mm	13mm	13mm	13mm
	41 x 6g	51 x 7g	41 x 6g	51 x 7g

**Fastener Centres**

**Inner Layer:** Fix 600mm centres at sheet perimeters and on top and bottom plates. Fix at 600mm up each stud.

**Outer Layer:** Fix at 300mm centres at sheet perimeters and on top and bottom plates and 300mm centres up each stud.

Place fasteners 50mm from sheet corners along the top and bottom plates. On end studs place additional fasteners 50-60mm vertically and no close than 10mm from plate to stud connections.

Place fasteners no closer than 12mm from the sheet edges and 18mm from sheet ends.

Place fasteners at 200mm centres where sheet end butt joints occur.

Avoid outer layer screws from hitting inner layer screws.

**Jointing**

**Inner Layer:** Unstopped

**Outer Layer:** All fastener heads stopped and all sheet joints reinforced with paper jointing tape and stopped. All in accordance with EPB® Plasterboard Installation Guide.

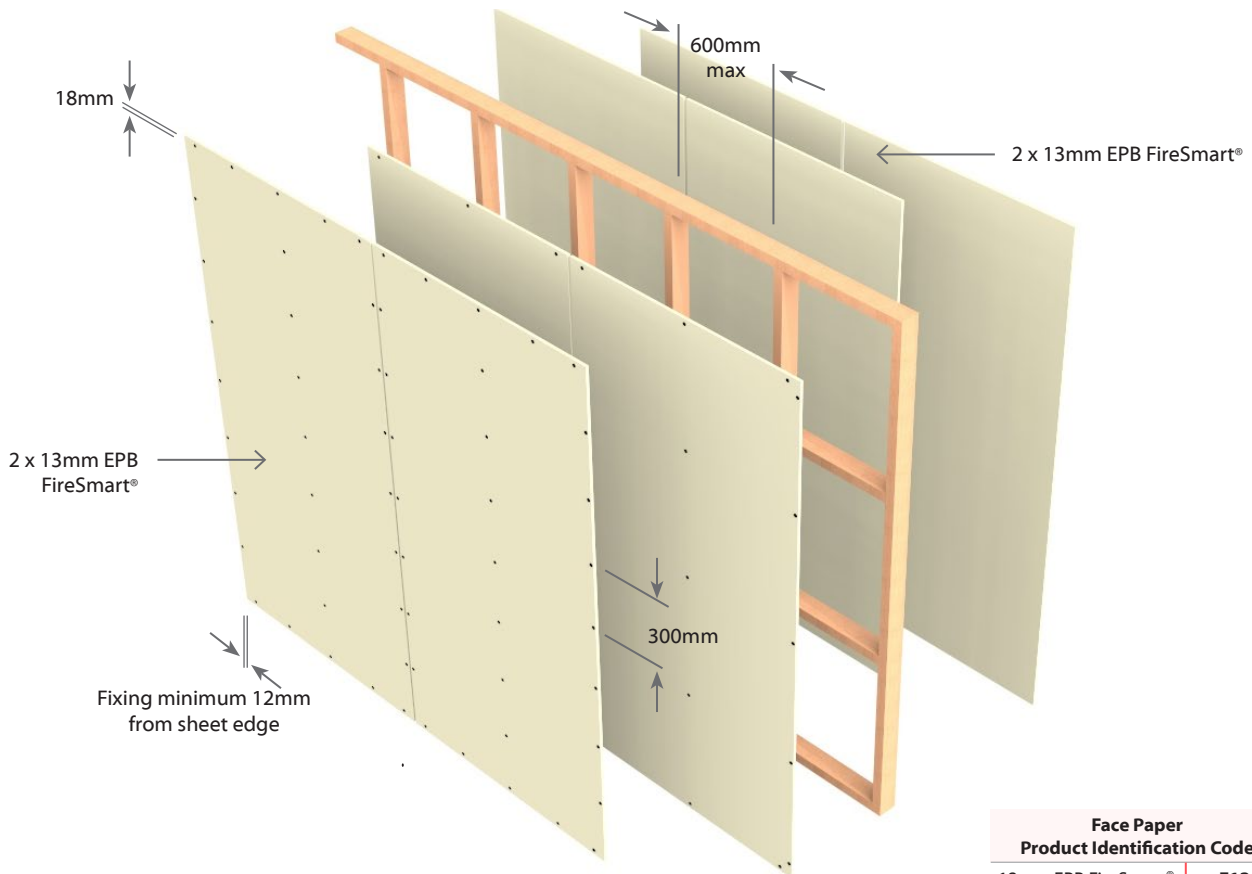



**E2sm10**

Smoke Separation - Timber or Steel Frame

Load Bearing

Two Way FRR

2 Layers: 1 Layer of Plasterboard to each side of frame

System Number	Lining Suffix	Fire Rating	Load Bearing Ability	Noise Control		Lining Requirement
				STC	Rw	
<b>E2sm10</b>	-	10/10/10	N/A	N/A	N/A	1 x minimum 10mm EPB® Plasterboard on One side 1 x minimum 10mm EPB® Plasterboard to Other side

**Framing**

Timber or Steel Frame designed to meet durability and structural criteria for strength and serviceability under dead and live loads.

Studs at 600mm centres maximum.

Stud width to be a minimum of 35mm.

**Plasterboard Lining**

One layer of minimum 10mm EPB® Plasterboard lining on each side of the framing.

Vertical or Horizontal fixing permitted. Use full height or full length sheets where possible.

For Horizontal Fixing, the horizontal sheet joints need not be formed directly over framing.

Sheets shall be touch fitted.

**Penetrations**

Penetrations in cavities are permitted on one side of the framing for plumbing and electrical services, with a maximum of two per stud bay. Metal plumbing services up to 65mm in diameter and metal flush boxes up to 90 x 50mm are permitted. Ensure all penetrations through smoke walls have sealant around the cover plates attached to metal flush boxes or around plumbing services.

**Fixing of Linings**

Fix the linings as per the EPB Plasterboard Installation Guide.

For higher FRR requirements follow the Fixing of Linings instruction for the relevant FRR system.

**Fasteners**

For minimum screw lengths, refer EPB® Plasterboard Installation guide. For multiple layer board combinations consider longer screw lengths, ensuring a minimum penetration of 25mm for timber and 12mm for steel.

**Fastener Centres**

Fix at 300mm centres at sheet perimeters, on top and bottom plates and 300mm centres up all end studs. When fixing horizontally, screw fasteners at the points where the horizontal joint crosses the stud.

Place fasteners 50mm from sheet corners along the top and bottom plates. On end studs place additional fasteners 50-60mm vertically and no close than 10mm from plate to stud connections.

Place fasteners no closer than 12mm from the sheet edges and 18mm from sheet ends.

Intermediate studs may be fixed with fasteners or adhesives. Fix at 300mm centres. Adhesives not to be placed at sheet edges or within 200mm of mechanical fasteners.

Ensure all perimeter gaps are plaster stopped or sealed with a general purpose flexible sealant ensuring the passage of smoke is restricted.

**Jointing**

All fastener heads stopped and all sheet joints reinforced with paper jointing tape and stopped. All in accordance with EPB® Plasterboard Installation Guide.

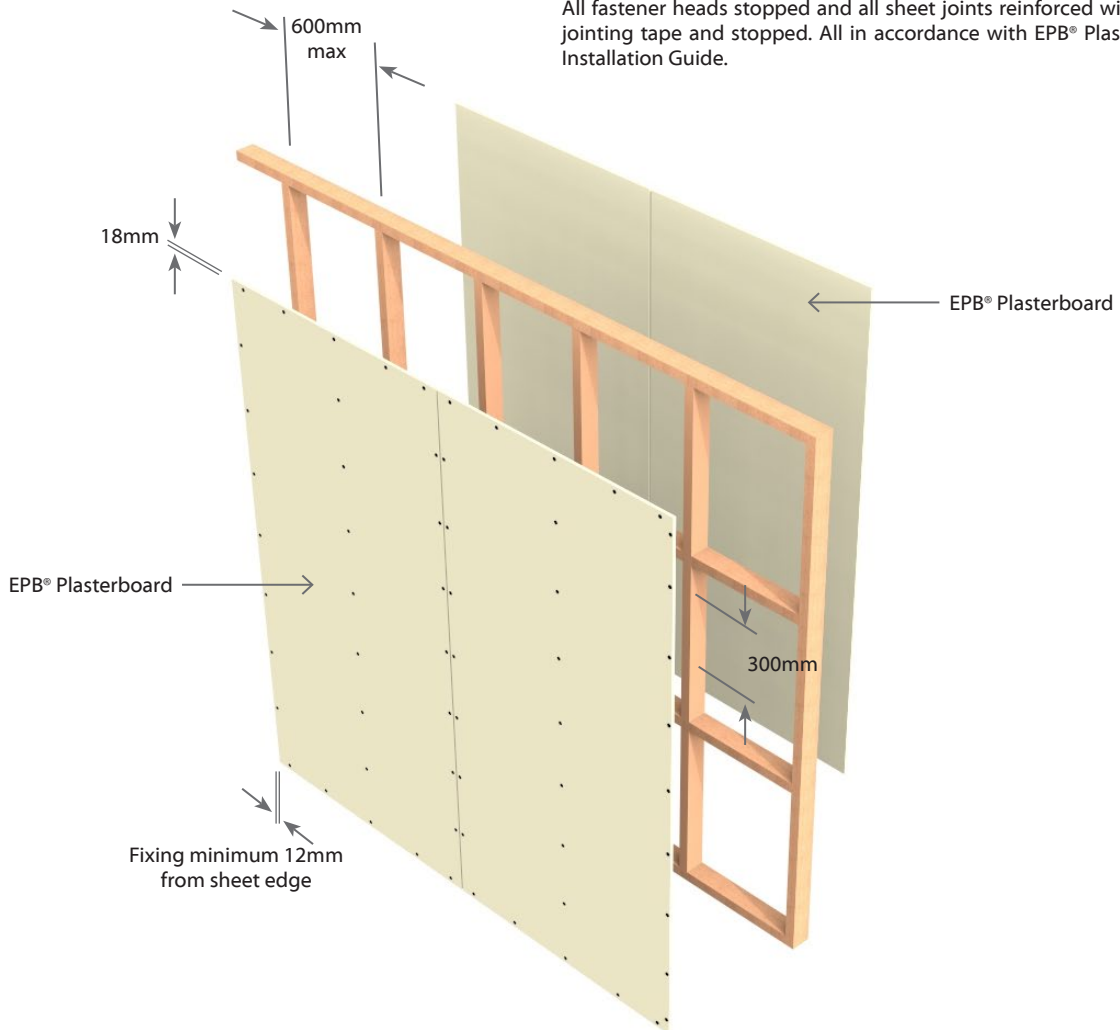



# Fire Rated Floor/Ceiling Systems

**E1FC15**

**Floor/Ceiling**

**Load Bearing**

**1 Layer: 1 Layer of Plasterboard to underside side of frame**

System Number	Lining Suffix	Fire Rating	Load Bearing Ability	Noise Control			Lining Requirement
				STC	Rw	IIC	
<b>E1FC15</b>	<b>-S13</b>	15/15/15	LB	38	37	31	1 x 13mm EPB® Standard

**Floor Framing**

Timber floor joists shall comply with NZS3604 with a minimum depth of 140mm x 45mm and spaced at no more than 600mm centres. Solid strutting is required in accordance with NZS3604.

Alternatively, a proprietary I-joist system may be used subject to specific structural design and approved by the normal building consent process.

Nogs fixed on the flat to receive the ends of flooring material shall be 90mm x 45mm minimum.

**Flooring**

Minimum flooring shall be nominal 20mm thick particle board or minimum 17mm thick structural plywood, fixed to the joists as per manufacturers' instructions.

Flooring sheet joints must either be formed over framing or have a polypropylene tongue and groove jointer.

**Ceiling Framing**

Nogs fixed on the flat to receive the EPB® Plasterboard lining shall be 70mm x 45mm minimum. They are spaced at 600mm centres for joist at 600mm centres or at 1200mm centres for joists at 450mm centres.

Nogs or framing is required at the perimeter of the fire rated ceiling.

**Plasterboard Lining**

**NB:** The installer must look for the Product Identification Code on the face paper to ensure the correct board type is installed. Refer to the Face Paper Product Identification Code table on this page.

One layer of 13mm EPB® Standard fixed at right angles directly to the underside of floor joists.

All joints must occur on joists and solid blocking.

Sheets shall be touch fitted.

**Fixing of Linings**

**Fasteners**

System Number	Single Layer
	High Thread Drywall Screws
<b>E1FC15-S13</b>	13mm
	41 x 6g

**Fastener Centres**

Place fasteners 150mm centres around the perimeter of each sheet. 200mm centres across each joist and at the centre of each nog.

Place fasteners no closer than 12mm from sheet edges and 18mm from sheet ends.

**Wall/Ceiling Junction**

The internal angle between the ceilings and walls must be protected by Cornice or square stopped corners, taped and filled in accordance with EPB Plasterboard Installation Guide.

**Jointing**

All fastener heads stopped and all sheet joints reinforced with paper jointing tape and stopped. All in accordance with the EPB® Plasterboard Installation Guide.

Face Paper	Product Identification Code
13mm EPB® Standard	<b>S13</b>

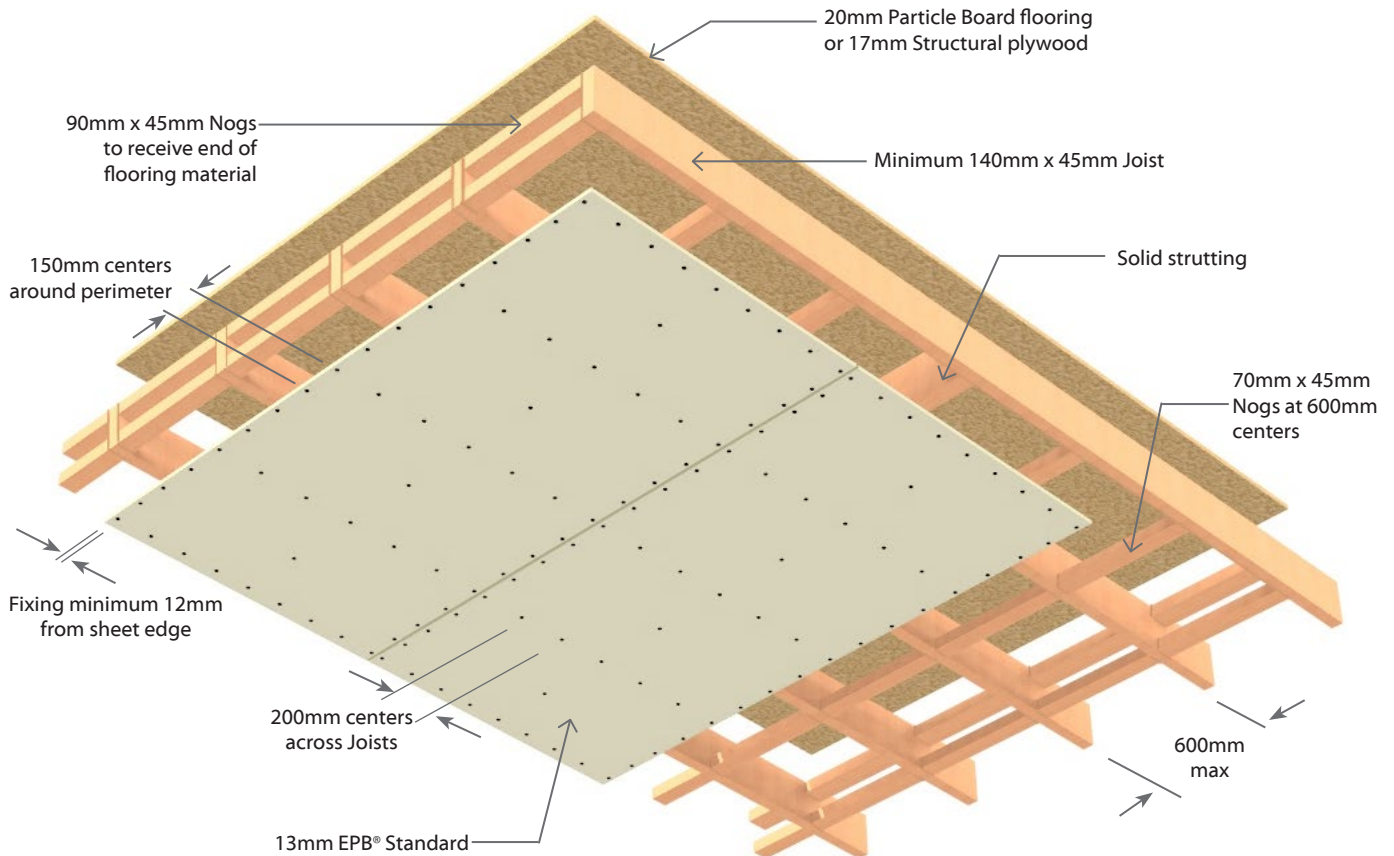

**E1FC30**

**Floor/Ceiling**

**Load Bearing**

**1 Layer: 1 Layer of Plasterboard to underside side of frame**

System Number	Lining Suffix	Fire Rating	Load Bearing Ability	Noise Control			Lining Requirement
				STC	Rw	IIC	
<b>E1FC30</b>	<b>-F13</b>	30/30/30	LB	39	38	32	1 x 13mm EPB FireSmart®

**Floor Framing**

Timber floor joists shall comply with NZS3604 with a minimum depth of 190mm x 45mm and spaced at no more than 600mm centres. Solid strutting is required in accordance with NZS3604.

Nogs fixed on the flat to receive the ends of flooring material shall be 90mm x 45mm minimum.

**Flooring**

Minimum flooring shall be nominal 20mm thick particle board or minimum 17mm thick structural plywood, fixed to the joists as per manufacturers' instructions.

Flooring sheet joints must either be formed over framing or have a polypropylene tongue and groove jointer.

**Ceiling Framing**

Nogs shall be 70mm x 35mm minimum, fixed on the flat in between joists to receive the EPB Plasterboard lining. They are spaced at 600mm centres for joist at 600mm centres or at 1200mm centres for joists at 450mm centres.

Nogs or framing is required at the perimeter of the fire rated ceiling.

**Alternative Framing**

In situations where NZS3604 allows for 140mm deep joists a 70mm x 45mm ceiling batten and nog shall be used to build up the joist depth.

Also in situations where the 70mm x 35mm ceiling battens have been fixed over the 190mm joists instead of nogged within the joists, the alternative framing method can be used to ensure that the fire integrity is maintained.

Refer to E1FC45 Alternative Framing specifications.

**Plasterboard Lining**

NB: The installer must look for the Product Identification Code on the face paper to ensure the correct board type is installed. Refer to the Face Paper Product Identification Code table on this page.

One layer of 13mm EPB FireSmart® fixed at right angles directly to the underside of floor joists.

All joints must occur on joists and solid blocking. Sheets to be touch fitted.

**Fixing of Linings**

**Fasteners**

System Number	Single Layer
	High Thread Drywall Screws
<b>E1FC30-F13</b>	13mm
	41 x 6g

**Fastener Centres**

Place fasteners 150mm centres around the perimeter of each sheet.

200mm centres across each joist and at the centre of each nog.

Place fasteners no closer than 12mm from sheet edges and 18mm from sheet ends.

**Wall/Ceiling Junction**

The internal angle between the ceilings and walls must be protected by Cornice or square stopped corners, taped and filled in accordance with EPB® Plasterboard Installation Guide.

**Jointing**

All fastener heads stopped and all sheet joints reinforced with paper jointing tape and stopped. All in accordance with the EPB® Plasterboard Installation Guide.

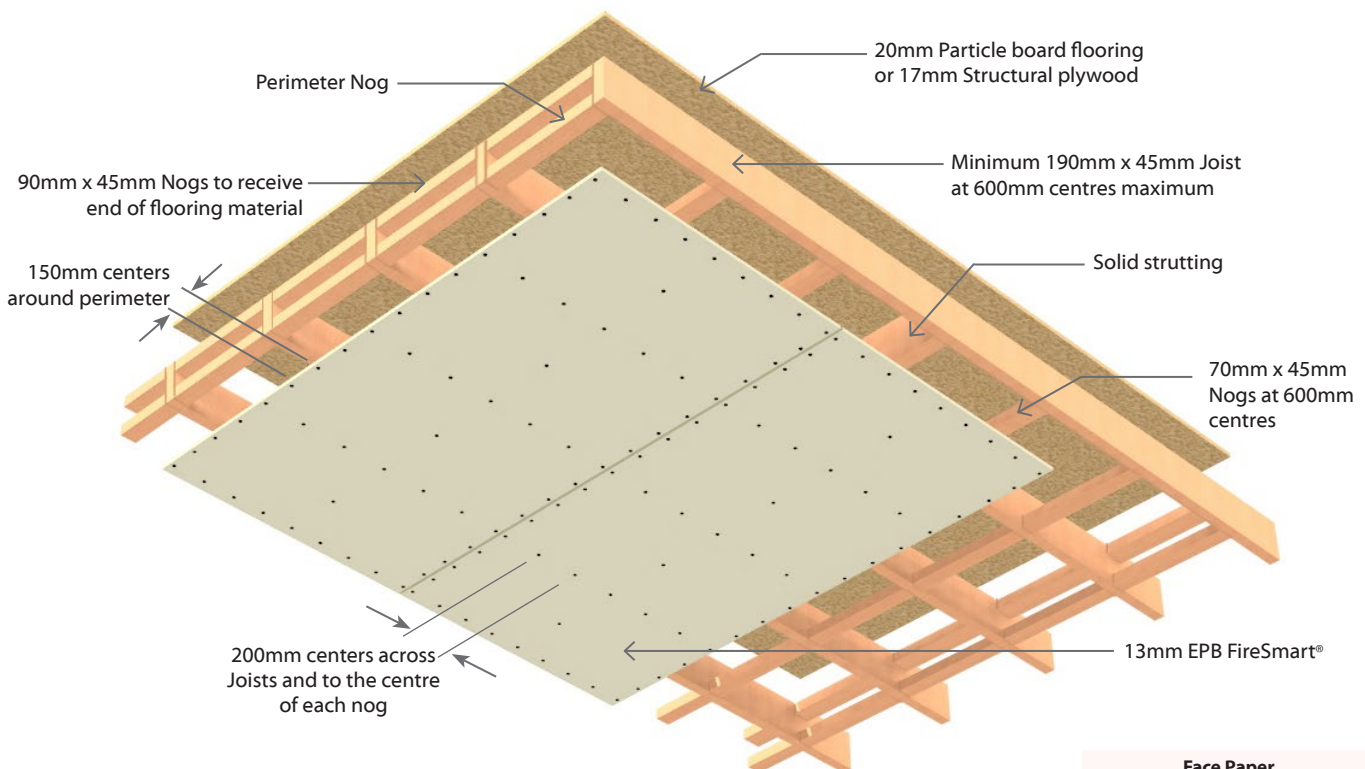

Face Paper	Product Identification Code
13mm EPB FireSmart®	<b>F13</b>



**E2FC30**

**Floor/Ceiling**

**Load Bearing**

**2 Layers: 2 Layers of Plasterboard to underside side of frame**

System Number	Lining Suffix	Fire Rating	Load Bearing Ability	Noise Control			Lining Requirement
				STC	Rw	IIC	
<b>E2FC30</b>	<b>-S26</b>	30/30/30	LB	39	38	32	2 x 13mm EPB® Standard

**Floor Framing**

Timber floor joists shall comply with NZS3604 with a minimum depth of 140mm x 45mm and spaced at no more than 600mm centres. Solid strutting is required in accordance with NZS3604.

Alternatively, a proprietary I-joist system may be used subject to specific structural design and approved by the normal building consent process.

Nogs fixed on the flat to receive the ends of flooring material shall be 90mm x 45mm minimum.

**Flooring**

Minimum flooring shall be nominal 20mm thick particle board or minimum 17mm thick structural plywood, fixed to the joists as per manufacturers' instructions.

Flooring sheet joints must either be formed over framing or have a polypropylene tongue and groove jointer.

**Ceiling Framing**

Nogs fixed on the flat to receive the EPB® Plasterboard lining shall be 70mm x 45mm minimum.

Nogs or framing is required at the perimeter of the fire rated ceiling.

**Plasterboard Lining**

**NB:** The installer must look for the Product Identification Code on the face paper to ensure the correct board type is installed. Refer to the Face Paper Product Identification Code table on this page.

Two layers of 13mm EPB® Standard fixed directly to the underside of floor joists.

All joints must occur on joists and solid blocking.

All sheet joints should be staggered 600mm between layers.

Sheets shall be touch fitted.

**Fixing of Linings Fasteners**

System Number	1 <sup>st</sup> Layer	2 <sup>nd</sup> Layer
	High Thread Drywall Screws	
<b>E2FC30-S26</b>	13mm	13mm
	41 x 6g	51 x 7g

**Fastener Centres**

Inner Layer: 150mm centres around the perimeter of each sheet, across each joist and at the centre of each nog.

Outer Layer: 150mm centres around the perimeter of each sheet and 200mm centres along each joist and at centre of each nog.

Place fasteners no closer than 12mm from sheet edges and 18mm from sheet ends.

Avoid outer layer screws from hitting inner layer screws.

**Wall/Ceiling Junction**

The internal angle between the ceilings and walls must be protected by Cornice or square stopped corners, taped and filled in accordance with EPB Plasterboard Installation Guide.

**Jointing**

Inner Layer: Unstopped.

Outer Layer: All fastener heads stopped and all sheet joints reinforced with paper jointing tape and stopped in accordance with the publication entitled EPB® Plasterboard Installation Guide.

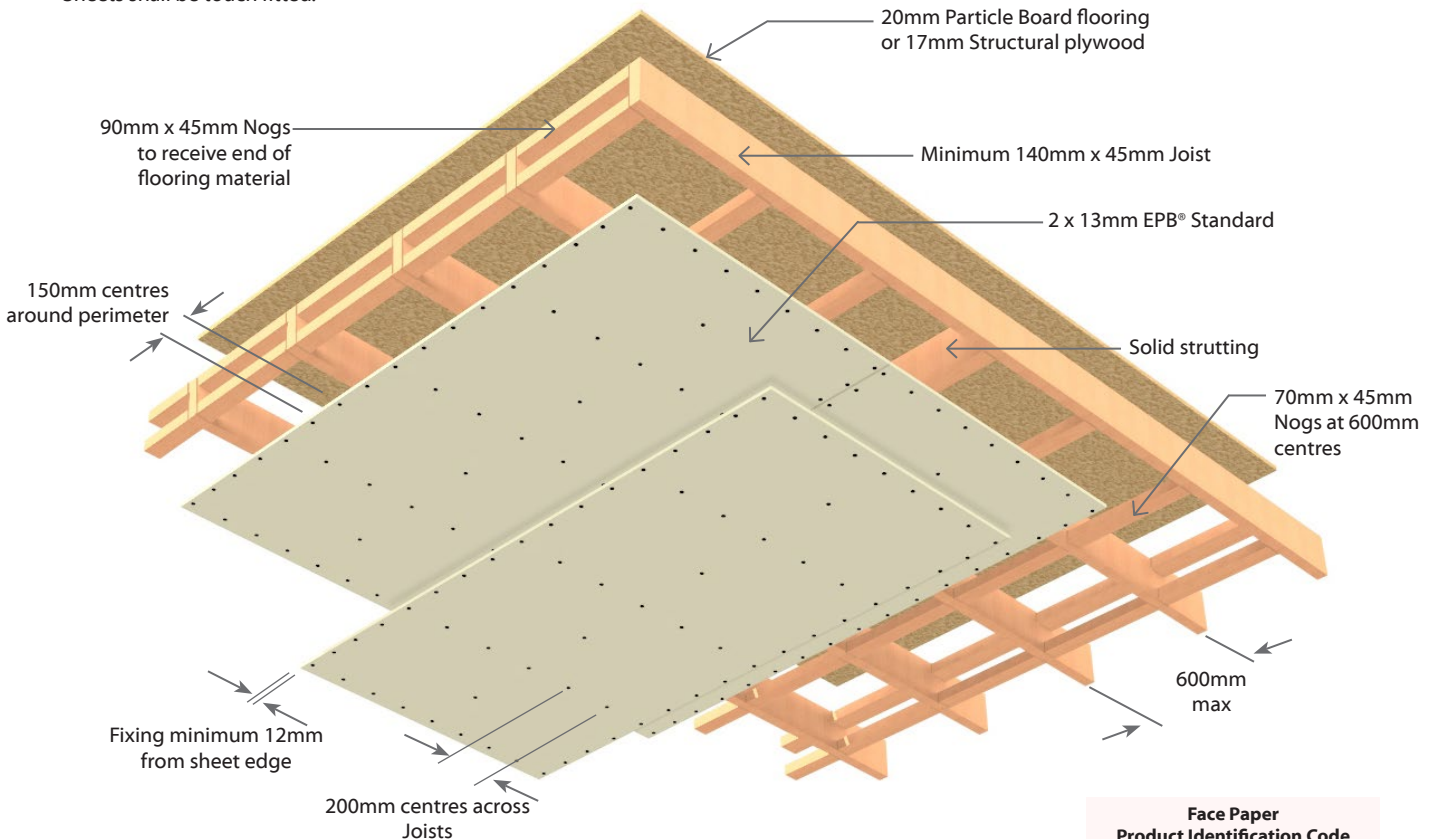

Face Paper Product Identification Code	
13mm EPB® Standard	<b>S13</b>



**E1FC45**

**Floor/Ceiling**

**Load Bearing**

**1 Layer: 1 Layer of Plasterboard to underside side of frame**

System Number	Lining Suffix	Fire Rating	Load Bearing Ability	Noise Control			Lining Requirement
				STC	Rw	IIC	
<b>E1FC45*</b>	<b>-F13</b>	45/45/45	LB	39	38	32	1 x 13mm EPB FireSmart®

**Floor Framing**

Timber floor joists shall comply with NZS3604 with a minimum depth of 190mm x 45mm and spaced at no more than 600mm centres. Solid strutting is required in accordance with NZS3604.

Nogs fixed on the flat to receive the ends of flooring material shall be 90mm x 45mm minimum.

**Flooring**

Minimum flooring shall be nominal 20mm thick particle board or minimum 17mm thick structural plywood, fixed to the joists as per manufacturers' instructions.

Flooring sheet joints must either be formed over framing or have a polypropylene tongue and groove jointer.

**Ceiling Framing**

Nogs shall be 70mm x 45mm minimum, fixed on the flat in between joists to receive the EPB® Plasterboard lining. They are spaced at 600mm centres for joist at 600mm centres or at 1200mm centres for joists at 450mm centres.

Nogs or framing is required at the perimeter of the fire rated ceiling.

**Alternative Framing**

In situations where NZS3604 allows for 140mm deep joists a 70mm x 45mm ceiling batten and nog can be used to build up the joist depth.

The 45mm x 45mm nog is required under all joists that are spaced at 600mm centres or under all joists which are at 450mm centres and the battens are spaced at 600mm centres.

Where joists are at 400mm centres or joists are at 450mm centres and the battens are at 450mm centres, then nogs are required at 1200mm centres.

Also in situations where ceiling battens have been fixed over the 190mm x 45mm joists instead of noggged within the joists, the alternative framing method can be used to ensure that the fire integrity is maintained.

Nogs or framing is required at the perimeter of the fire rated ceiling.

**Plasterboard Lining**

NB: The installer must look for the Product Identification Code on the face paper to ensure the correct board type is installed. Refer to the Face Paper Product Identification Code table on this page.

One layer of 13mm EPB FireSmart® fixed at right angles directly to the underside of floor joists.

All joints must occur on joists and solid blocking.

Sheets to be touch fitted.

**Fixing of Linings**

**Fasteners**

System Number	Single Layer
	High Thread Drywall Screws
<b>E1FC45-F13</b>	13mm
	51 x 7g

**Fastener Centres**

Place fasteners 150mm centres around the perimeter of each sheet.

200mm centres across each joist and at the centre of each nog.

Place fasteners no closer than 12mm from sheet edges and 18mm from sheet ends.

**Wall/Ceiling Junction**

The internal angle between the ceilings and walls must be protected by Cornice or square stopped corners, taped and filled in accordance with EPB Plasterboard Installation Guide.

**Jointing**

All fastener heads stopped and all sheet joints reinforced with paper jointing tape and stopped. All in accordance with the EPB® Plasterboard Installation Guide.

**\*Note: For 30/30/30 FRR**

If the actual FRR required is 30/30/30, reference can be made to either E1BC30 or E1FC30.



**E1FC45**

**Floor/Ceiling**

**Load Bearing**

**1** Layer: 1 Layer of Plasterboard to underside side of frame

System Number	Lining Suffix	Fire Rating	Load Bearing Ability	Noise Control			Lining Requirement
				STC	Rw	IIC	
<b>E1FC45</b>	<b>-F13</b>	45/45/45	LB	39	38	32	1 x 13mm EPB FireSmart®

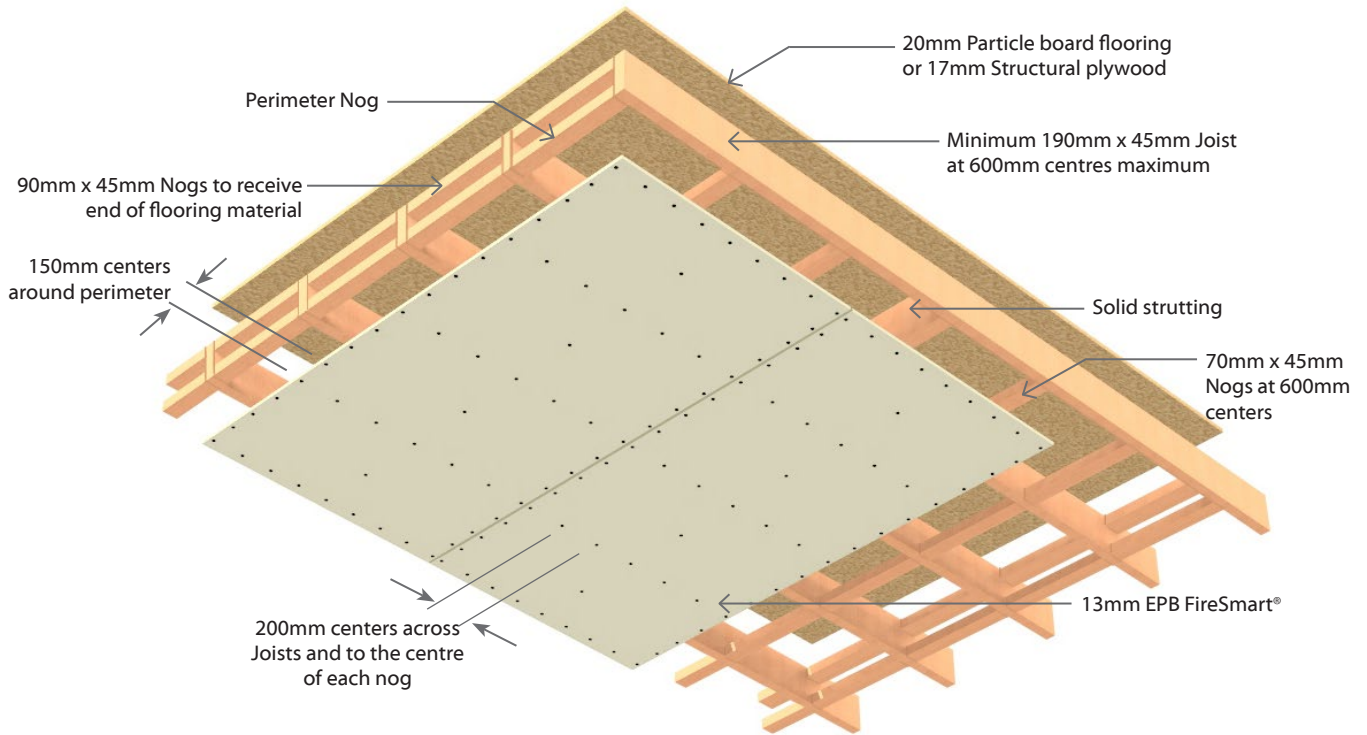

Face Paper	Product Identification Code
13mm EPB FireSmart®	<b>F13</b>

**Alternative Framing**

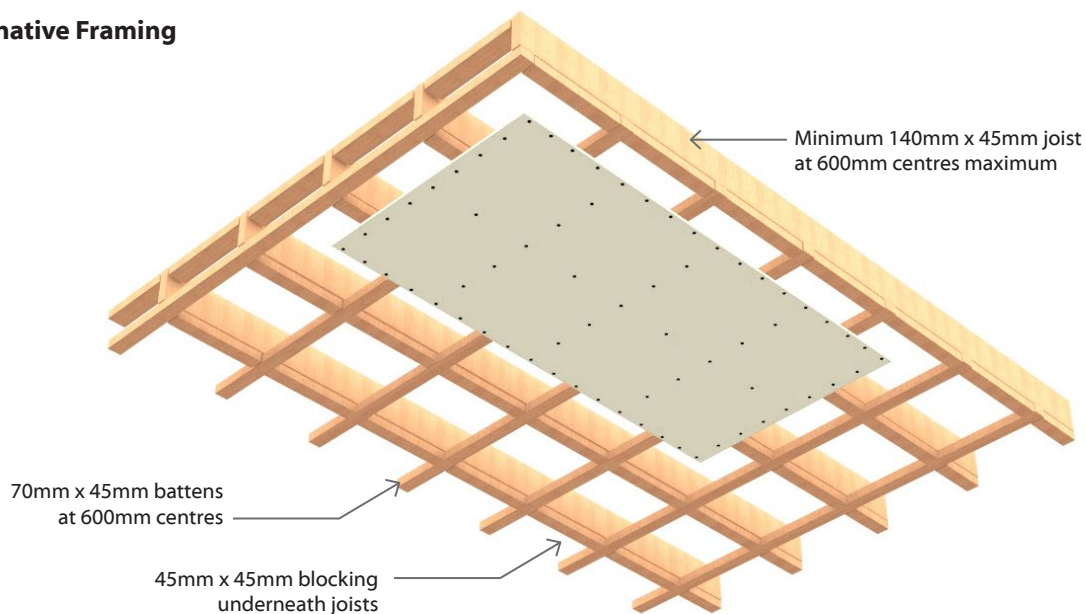

**E1FC60**

**Floor/Ceiling**

**Load Bearing**

**1 Layer: 1 Layer of Plasterboard to underside side of frame**

System Number	Lining Suffix	Fire Rating	Load Bearing Ability	Noise Control			Lining Requirement
				STC	Rw	IIC	
<b>E1FC60</b>	<b>-F16</b>	60/60/60	LB	39	39	32	1 x 16mm EPB FireSmart®

**Floor Framing**

Timber floor joists shall comply with NZS3604 with a minimum depth of 190mm x 45mm and spaced at no more than 600mm centres. Solid strutting is required in accordance with NZS3604.

Nogs fixed on the flat to receive the ends of flooring material shall be 90mm x 45mm minimum.

**Flooring**

Minimum flooring shall be nominal 20mm thick particle board or minimum 17mm thick structural plywood, fixed to the joists as per manufacturers' instructions.

Flooring sheet joints must either be formed over framing or have a polypropylene tongue and groove jointer.

**Ceiling Framing**

Nogs fixed on the flat to receive the EPB® Plasterboard lining shall be 70mm x 45mm minimum. They are spaced at 600mm centres for joist at 600mm centres or at 1200mm centres for joists at 450mm centres.

Nogs or framing is required at the perimeter of the fire rated ceiling.

**Alternative Framing**

In situations where NZS3604 allows for 140mm deep joists a 70mm x 45mm ceiling batten and nog can be used to build up the joist depth.

The 45mm x 45mm nog is required under all joists that are spaced at 600mm centres or under all joists which are at 450mm centres and the battens are spaced at 600mm centres.

Where joists are at 400mm centres or joists are at 450mm centres and the battens are at 450mm centres, then nogs are required at 1200mm centres.

Also in situations where the ceiling battens have been fixed over the 190mm x 45mm joists instead of within the joists, the alternative framing method can be used to ensure that the fire integrity is maintained.

Nogs or framing is required at the perimeter of the fire rated ceiling.

**Plasterboard Lining**

**NB:** The installer must look for the Product Identification Code on the face paper to ensure the correct board type is installed. Refer to the Face Paper Product Identification Code table on this page.

One layer of 16mm EPB FireSmart® fixed at right angles directly to the underside of floor joists.

All joints must occur on joists and solid blocking.

Sheets to be touch fitted.

**Fixing of Linings**

**Fasteners**

System Number	Single Layer
	High Thread Drywall Screws
<b>E1FC60-F16</b>	16mm
	51 x 7g

**Fastener Centres**

Place fasteners 150mm centres around the perimeter of each sheet.

200mm centres across each joist and at the centre of each nog.

Place fasteners no closer than 12mm from sheet edges and 18mm from sheet ends.

**Wall/Ceiling Junction**

The internal angle between the ceilings and walls must be protected by Cornice or square stopped corners, taped and filled in accordance with EPB Plasterboard Installation Guide.

**Jointing**

All fastener heads stopped and all sheet joints reinforced with paper jointing tape and stopped. All in accordance with the EPB® Plasterboard Installation Guide.



**E1FC60**

**Floor/Ceiling**

**Load Bearing**

**1** Layer: 1 Layer of Plasterboard to underside side of frame

System Number	Lining Suffix	Fire Rating	Load Bearing Ability	Noise Control			Lining Requirement
				STC	Rw	IIC	
<b>E1FC60</b>	<b>-F16</b>	60/60/60	LB	39	39	32	1 x 16mm EPB FireSmart®

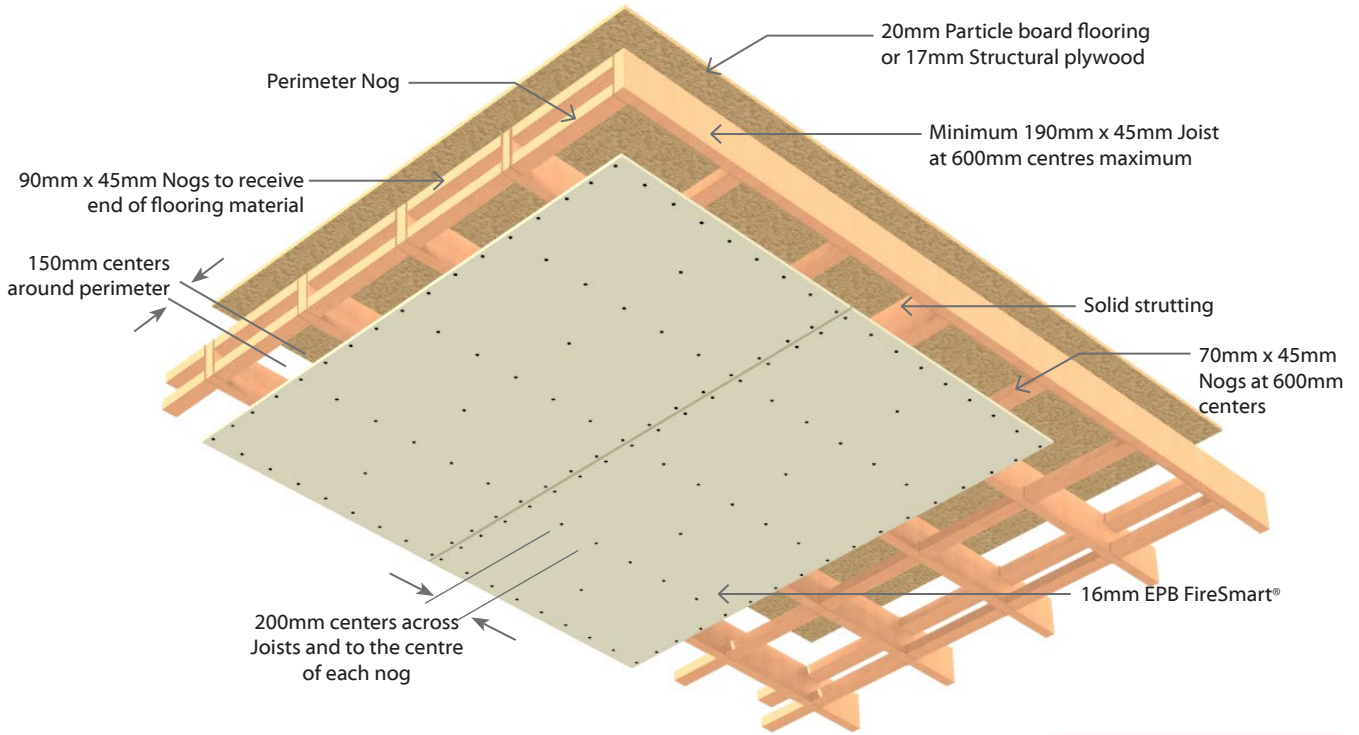

**Product Identification Code**  
 16mm EPB FireSmart® | **F16**

**Alternative Framing**

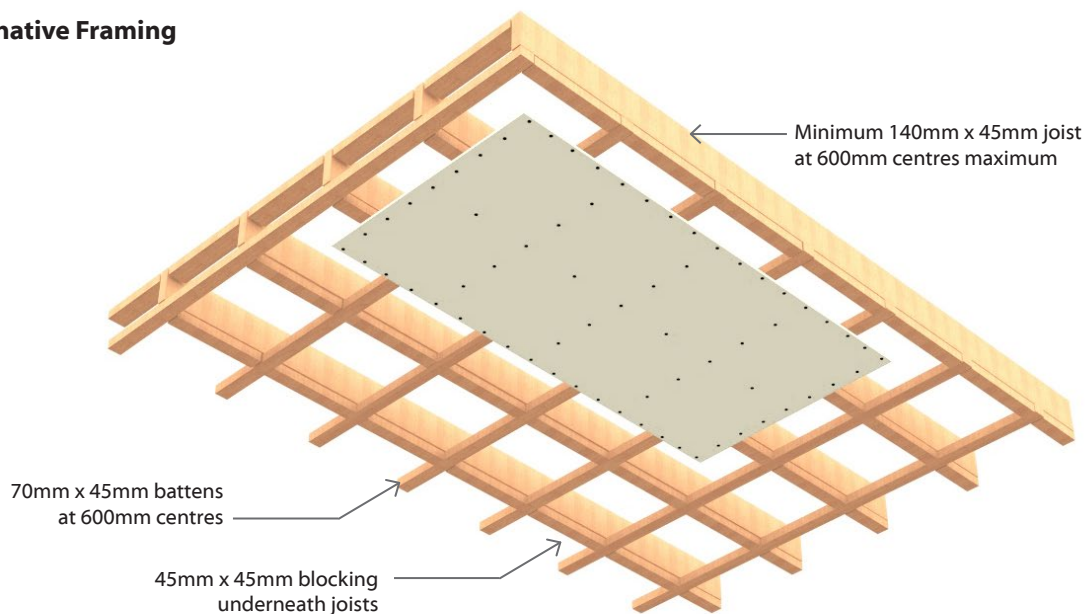

**E2FC60**

**Floor/Ceiling**

**Load Bearing**

**2 Layers: 2 Layers of Plasterboard to underside side of frame**

System Number	Lining Suffix	Fire Rating	Load Bearing Ability	Noise Control			Lining Requirement
				STC	Rw	IIC	
<b>E2FC60</b>	<b>-FS26</b>	60/60/60	LB	40	39	33	1 x 13mm EPB FireSmart® and 1 x 13mm EPB® Standard
	<b>-F26</b>	60/60/60	LB	41	40	34	2 x 13mm EPB FireSmart®

**Floor Framing**

Timber floor joists shall comply with NZS3604 and be a minimum of 190mm x 45mm and spaced at no more than 600mm centres. Solid strutting is required in accordance with NZS 3604.

Nogs fixed on the flat to receive the ends of flooring material shall be 90mm x 45mm minimum.

**Flooring**

Minimum flooring shall be nominal 20mm thick particle board or minimum 17mm thick structural plywood, fixed to the joists as per manufacturers' instructions.

Flooring sheet joints must either be formed over framing or have a polypropylene tongue and groove jointer.

**Ceiling Framing**

Nogs fixed on the flat to receive the EPB® Plasterboard lining shall be 70mm x 45mm minimum.

Nogs or framing is required at the perimeter of the fire rated ceiling.

**Alternative Framing**

In situations where NZS3604 allows for 140mm deep joists a 70mm x 45mm ceiling batten and nog can be used to build up the joist depth.

Also in situations where the ceiling battens have been fixed over the joists instead of within the joists, the alternative framing method can be used to ensure that the fire integrity is maintained.

Refer to E1FC60 Alternative Framing .

**Plasterboard Lining**

**NB:** The installer must look for the Product Identification Code on the face paper to ensure the correct board type is installed. Refer to the Face Paper Product Identification Code table on this page.

Two layers of 13mm EPB® Plasterboard as per specified system above, fixed directly to the underside of floor joists.

All joints must occur on joists and solid blocking.

All sheet joints should be staggered 600mm between layers.

Sheets shall be touch fitted.

**Fixing of Linings**

**Fasteners**

System Number	1 <sup>st</sup> Layer	2 <sup>nd</sup> Layer
		High Thread Drywall Screws
<b>E2FC60-FS26</b>	13mm	13mm
<b>E2FC60-F26</b>	51 x 7g	63 x 8g

**Fastener Centres**

Inner Layer: 150mm centres around the perimeter of each sheet, across each joist and at the centre of each nog.

Outer Layer: 150mm centres around the perimeter of each sheet and 200mm centres along each joist and at centre of each nog.

Place fasteners no closer than 12mm from sheet edges and 18mm from sheet ends.

Avoid outer layer screws from hitting inner layer screws.

**Wall/Ceiling Junction**

The internal angle between the ceilings and walls must be protected by Cornice or square stopped corners, taped and filled in accordance with EPB® Plasterboard Installation Guide.

**Jointing**

Inner Layer: Unstopped.

Outer Layer: All fastener heads stopped and all sheet joints reinforced with paper jointing tape and stopped in accordance with the publication entitled EPB® Plasterboard Installation Guide.

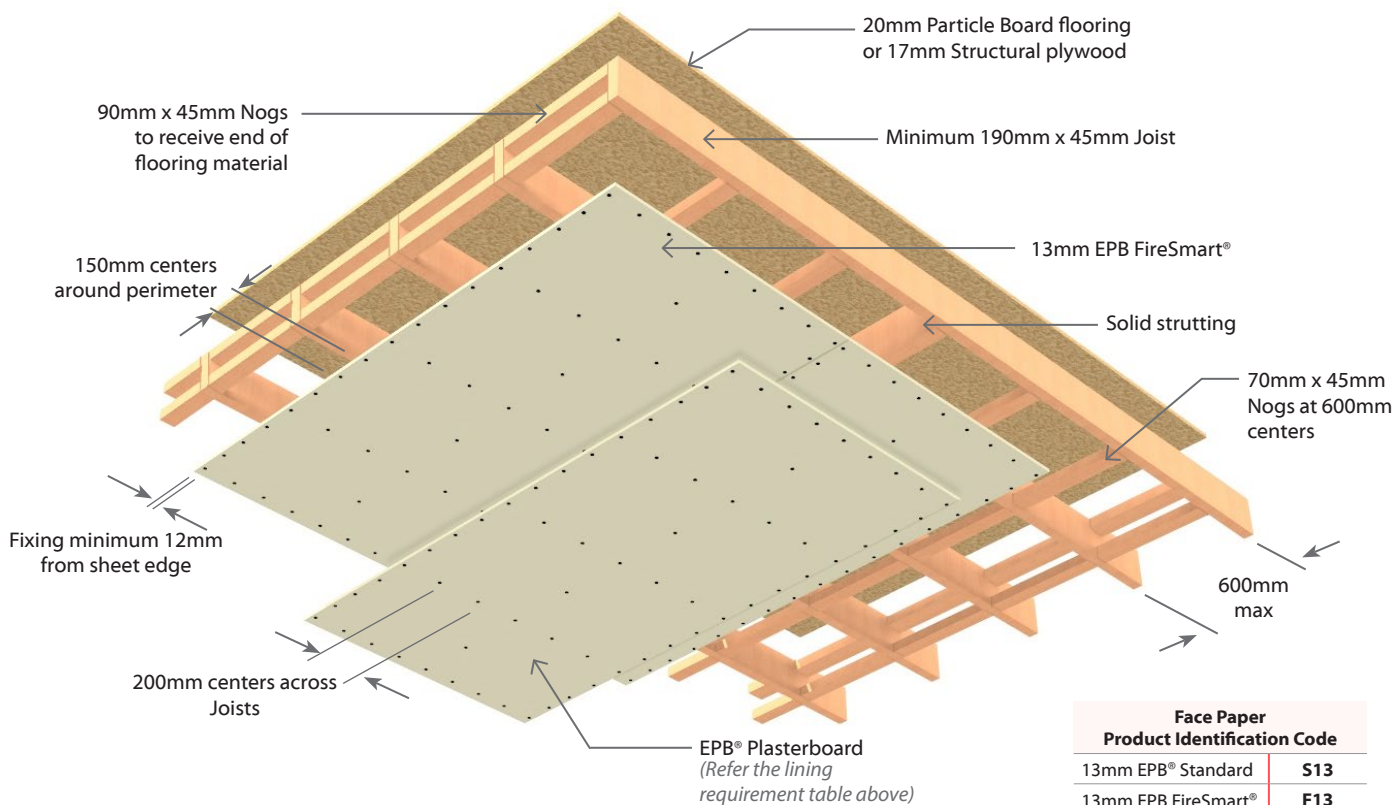

**E2FC90**

**Floor/Ceiling**

**Load Bearing**

**2 Layers: 2 Layer of Plasterboard to underside side of frame**

System Number	Lining Suffix	Fire Rating	Load Bearing Ability	Noise Control			Lining Requirement
				STC	Rw	IIC	
<b>E2FC90</b>	<b>-F29</b>	90/90/90	LB	41	40	34	1 x 16mm EPB FireSmart® and 1 x 13mm EPB FireSmart®

**Floor Framing**

Timber floor joists shall comply with NZS3604 and be a minimum of 190mm x 45mm and spaced at no more than 600mm centres. Solid strutting is required in accordance with NZS 3604.

Nogs fixed on the flat to receive the ends of flooring material shall be 90mm x 45mm minimum.

**Flooring**

Minimum flooring shall be nominal 20mm thick particle board or minimum 17mm thick structural plywood, fixed to the joists as per manufacturers' instructions.

Flooring sheet joints must either be formed over framing or have a polypropylene tongue and groove jointer.

**Ceiling Framing**

Nogs fixed on the flat to receive the EPB® Plasterboard lining shall be 70mm x 45mm minimum.

Nogs or framing is required at the perimeter of the fire rated ceiling.

**Plasterboard Lining**

**NB:** The installer must look for the Product Identification Code on the face paper to ensure the correct board type is installed. Refer to the Face Paper Product Identification Code table on this page.

One layer of 16mm EPB FireSmart® & One layer of 13mm EPB FireSmart® lining fixed directly to the underside of floor joists.

All joints must occur on joists and solid blocking.

All sheet joints should be staggered 600mm between layers.

Sheets shall be touch fitted.

**Fixing of Linings**

**Fasteners**

System Number	1 <sup>st</sup> Layer	2 <sup>nd</sup> Layer
	High Thread Drywall Screws	
<b>E2FC90-F29</b>	16mm	13mm
	51 x 7g	63 x 8g

**Fastener Centres**

Inner Layer: 150mm Centres around the perimeter of each sheet, across each joist and at the centre of each nog.

Outer Layer: 150mm centres around the perimeter of each sheet and 200mm centres along each joist and at centre of each nog.

Place fasteners no closer than 12mm from sheet edges and 18mm from sheet ends.

Avoid outer layer screws from hitting inner layer screws.

**Wall/Ceiling Junction**

The internal angle between the ceilings and walls must be protected by Cornice or square stopped corners, taped and filled in accordance with EPB® Plasterboard Installation Guide.

**Jointing**

Inner Layer: Unstopped.

Outer Layer: All fastener heads stopped and all sheet joints reinforced with paper jointing tape and stopped in accordance with the publication entitled EPB® Plasterboard Installation Guide.

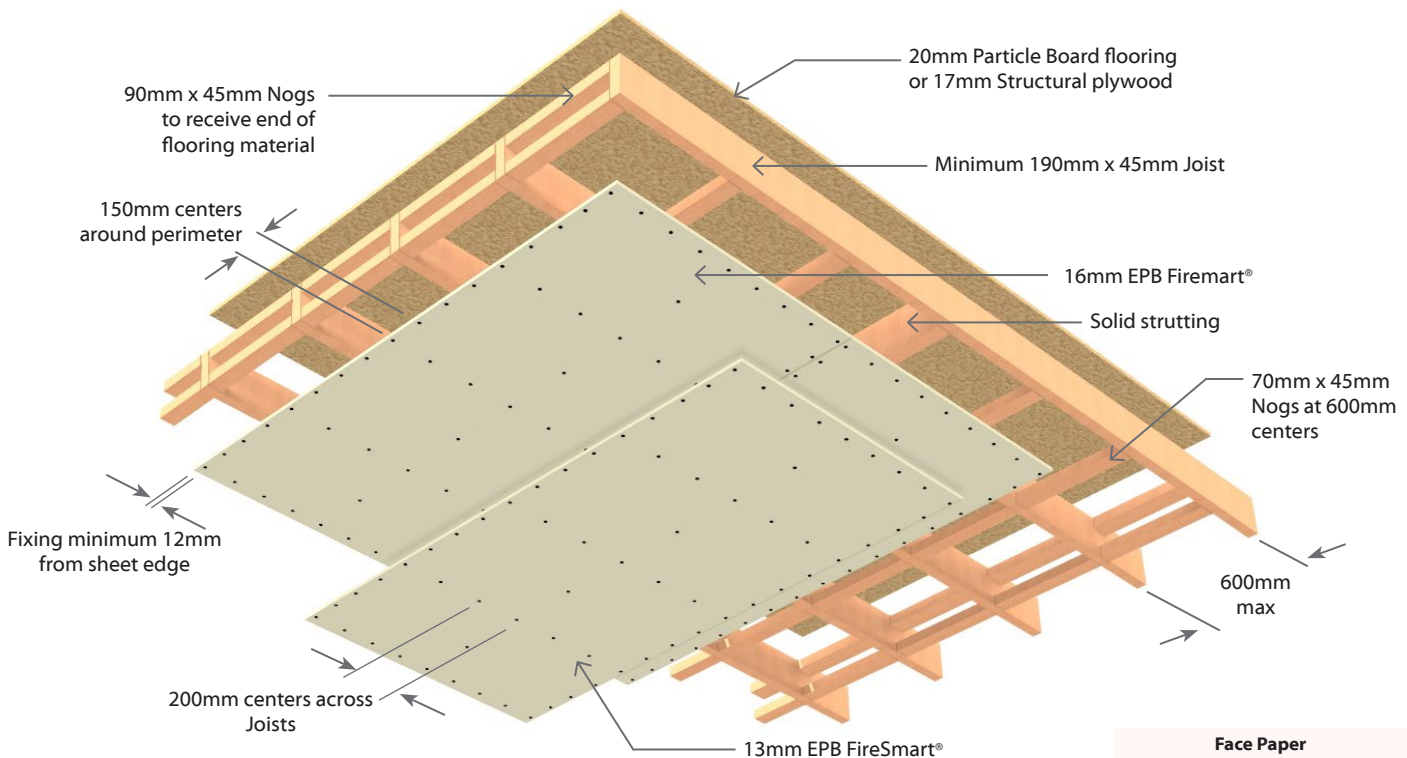

Face Paper Product Identification Code	
13mm EPB FireSmart®	<b>F13</b>
16mm EPB FireSmart®	<b>F16</b>



**E3FC120**

**Floor/Ceiling**

**Load Bearing**

**3 Layers: 3 Layer of Plasterboard to underside side of frame**

System Number	Lining Suffix	Fire Rating	Load Bearing Ability	Noise Control			Lining Requirement
				STC	Rw	IIC	
<b>E3FC120</b>	<b>-F45</b>	120/120/120	LB	43	42	35	1 x 13mm EPB FireSmart® and 2 x 16mm EPB FireSmart®

**Floor Framing**

Timber floor joists shall comply with NZS3604 and be a minimum of 190mm x 45mm and spaced at no more than 600mm centres. Solid strutting is required in accordance with NZS 3604.

Nogs fixed on the flat to receive the ends of flooring material shall be 90mm x 45mm minimum.

**Flooring**

Minimum flooring shall be nominal 20mm thick particle board or minimum 17mm thick structural plywood, fixed to the joists as per manufacturers' instructions.

Flooring sheet joints must either be formed over framing or have a polypropylene tongue and groove jointer.

**Ceiling Framing**

Nogs fixed on the flat to receive the EPB® Plasterboard lining shall be 70mm x 45mm minimum.

Nogs or framing is required at the perimeter of the fire rated ceiling.

**Plasterboard Lining**

**NB:** The installer must look for the Product Identification Code on the face paper to ensure the correct board type is installed. Refer to the Face Paper Product Identification Code table on this page.

Three layers of 13mm EPB FireSmart® fixed directly to the underside of floor joists. All joints must occur on joists and solid blocking.

All sheet joints should be staggered 600mm between layers.

Sheets shall be touch fitted.

**Fixing of Linings**

**Fasteners**

System Number	1 <sup>st</sup> Layer	2 <sup>nd</sup> Layer	3 <sup>rd</sup> Layer
	High Thread Drywall Screws		
<b>E3FC120-F45</b>	13mm	16mm	16mm
	51 x 7g	63 x 8g	63 x 8g

**Fastener Centres**

Inner Layer: 150mm centres around the perimeter of each sheet, across each joist and at the centre of each nog.

Outer Layer: 150mm centres around the perimeter of each sheet and 200mm centres along each joist and at centre of each nog.

Place fasteners no closer than 12mm from sheet edges and 18mm from sheet ends.

Avoid outer layer screws from hitting inner layer screws.

**Wall/Ceiling Junction**

The internal angle between the ceilings and walls must be protected by Cornice or square stopped corners, taped and filled in accordance with EPB® Plasterboard Installation Guide.

**Jointing**

Inner Layers: Unstopped.

Outer Layer: All fastener heads stopped and all sheet joints reinforced with paper jointing tape and stopped in accordance with the publication entitled EPB® Plasterboard Installation Guide.

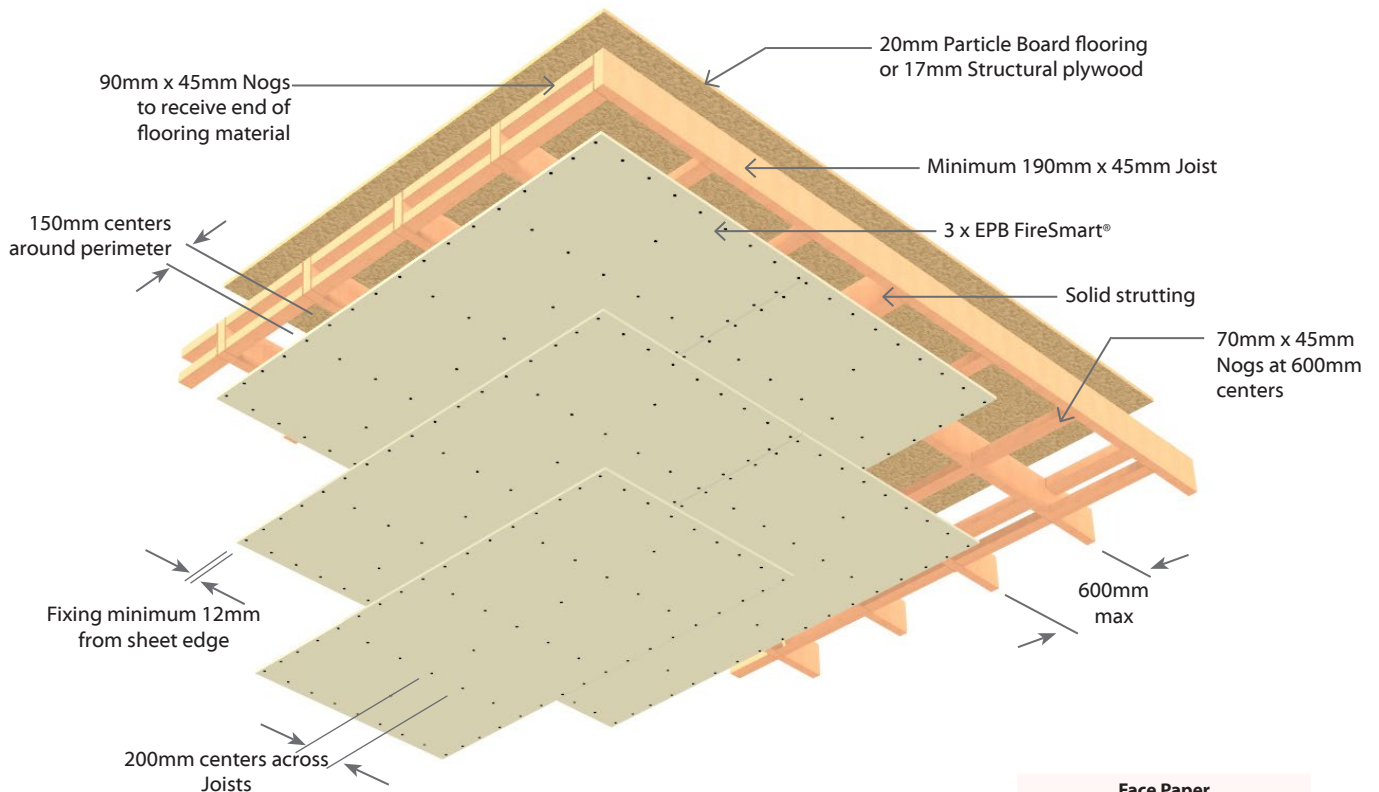

Face Paper Product Identification Code	
13mm EPB FireSmart®	<b>F13</b>
16mm EPB FireSmart®	<b>F16</b>



**E1CJ30**

**Composite Joist Floor/Ceiling**

**Load Bearing**

**1 Layer: 1 Layer of Plasterboard to underside side of frame**

System Number	Lining Suffix	Fire Rating	Load Bearing Ability	Noise Control			Lining Requirement
				STC	Rw	IIC	
<b>E1CJ30</b>	<b>-F13</b>	30/30/30	LB	39	38	32	1 x 13mm EPB FireSmart®

**Floor Framing**

Composite Floor joists may be either hySPAN® or hyJOIST®. Joists shall be covered by specific engineering design for strength and serviceability. A minimum depth of 190mm and spaced at no more than 600mm centres.

Nogs fixed on the flat to receive the ends of flooring material shall be 90mm x 45mm minimum.

Consult the beam manufacturer re construction of the solid blocking contained in floor/ceiling to wall junctions.

**Flooring**

Minimum flooring shall be nominal 20mm thick particle board or minimum 17mm thick structural plywood, fixed to the joists as per manufacturers' instructions.

Flooring sheet joints must either be formed over framing or have a polypropylene tongue and groove jointer.

**Ceiling Framing**

Nogs shall be 70mm x 35mm minimum, fixed on the flat in between joists to receive the EPB® Plasterboard lining. They are spaced at 600mm centres for joist at 600mm centres or at 1200mm centres for joists at 450mm centres.

Nogs or framing is required at the perimeter of the fire rated ceiling.

**Plasterboard Lining**

**NB:** The installer must look for the Product Identification Code on the face paper to ensure the correct board type is installed. Refer to the Face Paper Product Identification Code table on this page.

One layer of 13mm EPB FireSmart® fixed at right angles directly to the underside of floor joists.

All joints must occur on joists and solid blocking.

Sheets to be touch fitted.

**Fixing of Linings**

**Fasteners**

System Number	Single Layer
	High Thread Drywall Screws
<b>E1CJ30-F13</b>	13mm
	41 x 6g

**Fastener Centres**

Place fasteners 150mm centres around the perimeter of each sheet.

200mm centres across each joist and at the centre of each nog.

Place fasteners no closer than 12mm from sheet edges and 18mm from sheet ends.

**Wall/Ceiling Junction**

The internal angle between the ceilings and walls must be protected by Cornice or square stopped corners, taped and filled in accordance with EPB® Plasterboard Installation Guide.

**Jointing**

All fastener heads stopped and all sheet joints reinforced with paper jointing tape and stopped. All in accordance with the EPB® Plasterboard Installation Guide.

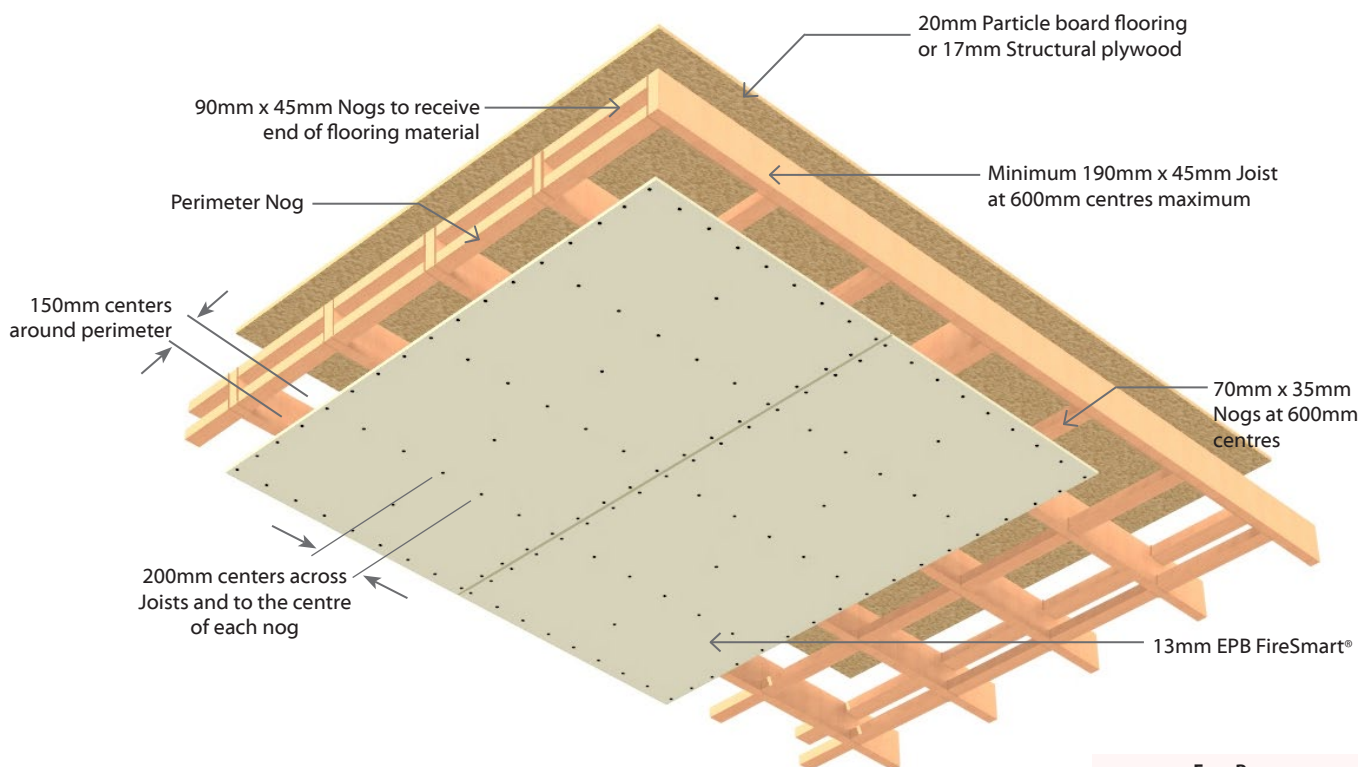

Face Paper Product Identification Code
13mm EPB FireSmart®   <b>F13</b>



2 Layers: 2 Layers of Plasterboard to underside side of frame

System Number	Lining Suffix	Fire Rating	Load Bearing Ability	Noise Control			Lining Requirement
				STC	Rw	IIC	
E2CJ30	-S26	30/30/30	LB	39	38	32	2 x 13mm EPB® Standard

**Floor Framing**

Composite Floor joists may be either hySPAN® or hyJOIST®. Joists shall be covered by specific engineering design for strength and serviceability. A minimum depth of 190mm and spaced at no more than 600mm centres.

Nogs fixed on the flat to receive the ends of flooring material shall be 90mm x 45mm minimum.

Consult the beam manufacturer re construction of the solid blocking contained in floor/ceiling to wall junctions.

**Flooring**

Minimum flooring shall be nominal 20mm thick particle board or minimum 17mm thick structural plywood, fixed to the joists as per manufacturers' instructions.

Flooring sheet joints must either be formed over framing or have a polypropylene tongue and groove jointer.

**Ceiling Framing**

Nogs fixed on the flat to receive the EPB® Plasterboard lining shall be 70mm x 35mm minimum and spaced at 600mm for joists at 600mm, or at 1200mm for joists at 400 or 450mm.

Nogs or framing is required at the perimeter of the fire rated ceiling.

**Plasterboard Lining**

**NB:** The installer must look for the Product Identification Code on the face paper to ensure the correct board type is installed. Refer to the Face Paper Product Identification Code table on this page.

Two layers of 13mm EPB® Standard fixed directly to the underside of floor joists. All joints must occur on joists and solid blocking.

All sheet joints should be staggered 600mm between layers.

Sheets shall be touch fitted.

**Fixing of Linings**

**Fasteners**

System Number	1 <sup>st</sup> Layer	2 <sup>nd</sup> Layer
	High Thread Drywall Screws	
E2CJ30-S26	13mm	13mm
	41 x 6g	51 x 7g

**Fastener Centres**

Inner Layer: 150mm centres around the perimeter of each sheet, across each joist and at the centre of each nog.

Outer Layer: 150mm centres around the perimeter of each sheet and 200mm centres along each joist and at centre of each nog.

Place fasteners no closer than 12mm from sheet edges and 18mm from sheet ends.

Avoid outer layer screws from hitting inner layer screws.

**Wall/Ceiling Junction**

The internal angle between the ceilings and walls must be protected by Cornice or square stopped corners, taped and filled in accordance with EPB® Plasterboard Installation Guide.

**Jointing**

Inner Layer: Unstopped.

Outer Layer: All fastener heads stopped and all sheet joints reinforced with paper jointing tape and stopped in accordance with the publication entitled EPB® Plasterboard Installation Guide.

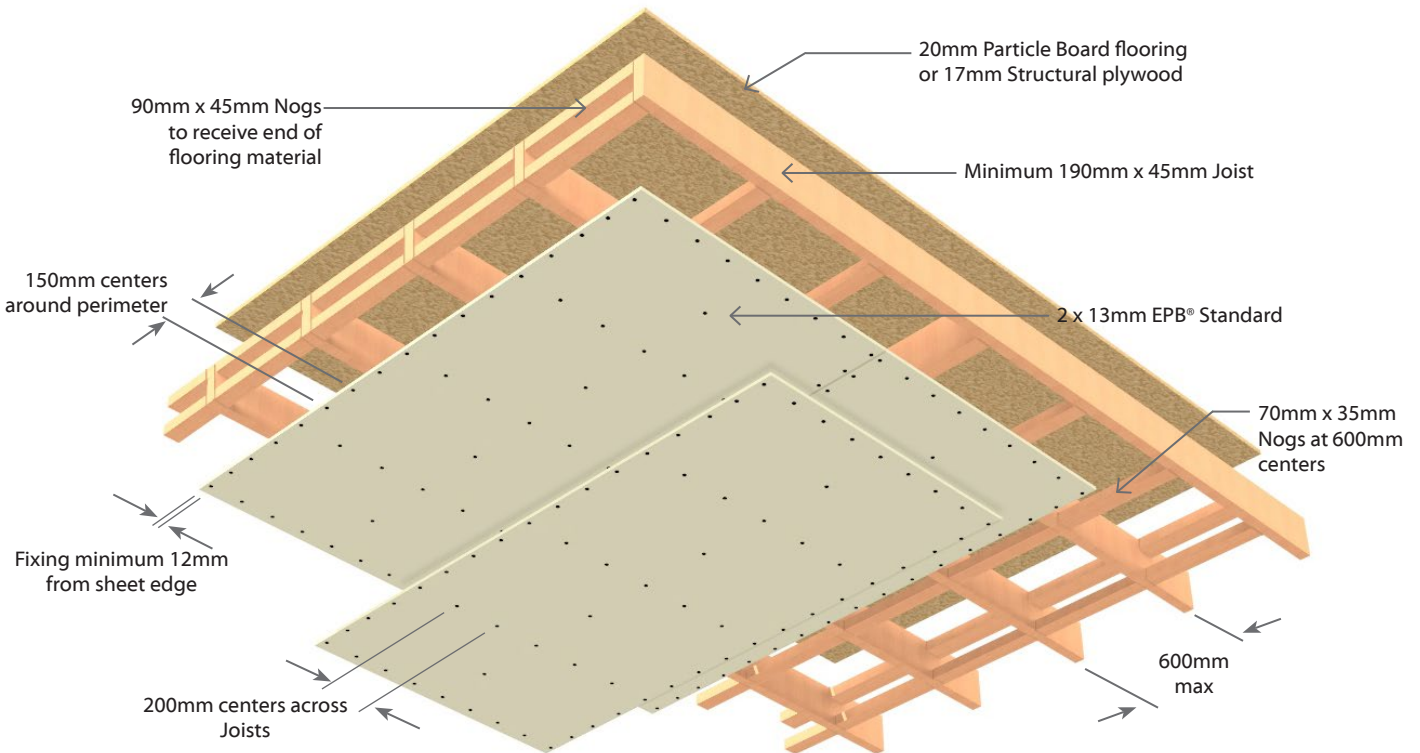

Face Paper	Product Identification Code
13mm EPB® Standard	S13



**E1CJ45**

**Composite Joist Floor/Ceiling**

**Load Bearing**

**1 Layer: 1 Layer of Plasterboard to underside side of frame**

System Number	Lining Suffix	Fire Rating	Load Bearing Ability	Noise Control			Lining Requirement
				STC	Rw	IIC	
<b>E1CJ45*</b>	<b>-F13</b>	45/45/45	LB	39	38	32	1 x 13mm EPB FireSmart®

**Floor Framing**

Composite Floor joists may be either hySPAN® or hyJOIST®. Joists shall be covered by specific engineering design for strength and serviceability. A minimum depth of 190mm and spaced at no more than 600mm centres.

Nogs fixed on the flat to receive the ends of flooring material shall be 90mm x 45mm minimum.

Consult the beam manufacturer re construction of the solid blocking contained in floor/ceiling to wall junctions.

**Flooring**

Minimum flooring shall be nominal 20mm thick particle board or minimum 17mm thick structural plywood, fixed to the joists as per manufacturers' instructions.

Flooring sheet joints must either be formed over framing or have a polypropylene tongue and groove jointer.

**Ceiling Framing**

Nogs fixed on the flat to receive the EPB® Plasterboard lining shall be 70mm x 45mm minimum and spaced at 600mm for joists at 600mm, or at 1200mm for joists at 400 or 450mm.

Nogs or framing is required at the perimeter of the fire rated ceiling.

**Plasterboard Lining**

**NB:** The installer must look for the Product Identification Code on the face paper to ensure the correct board type is installed. Refer to the Face Paper Product Identification Code table on this page.

One layer of 13mm EPB FireSmart® fixed at right angles directly to the underside of floor joists.

All joints must occur on joists and solid blocking.

Sheets to be touch fitted.

**Fixing of Linings**

**Fasteners**

System Number	1 <sup>st</sup> Layer
	High Thread Drywall Screws
<b>E1CJ45-F13</b>	13mm
	41 x 6g

**Fastener Centres**

Place fasteners 150mm centres around the perimeter of each sheet. 200mm centres across each joist and at the centre of each nog.

Place fasteners no closer than 12mm from sheet edges and 18mm from sheet ends.

**Wall/Ceiling Junction**

The internal angle between the ceilings and walls must be protected by Cornice or square stopped corners, taped and filled in accordance with EPB® Plasterboard Installation Guide.

**Jointing**

All fastener heads stopped and all sheet joints reinforced with paper jointing tape and stopped. All in accordance with the EPB® Plasterboard Installation Guide.

**\*Note: For 30/30/30 FRR**

If the actual FRR required is 30/30/30, reference can be made to either E1BC30 or E1CJ30.

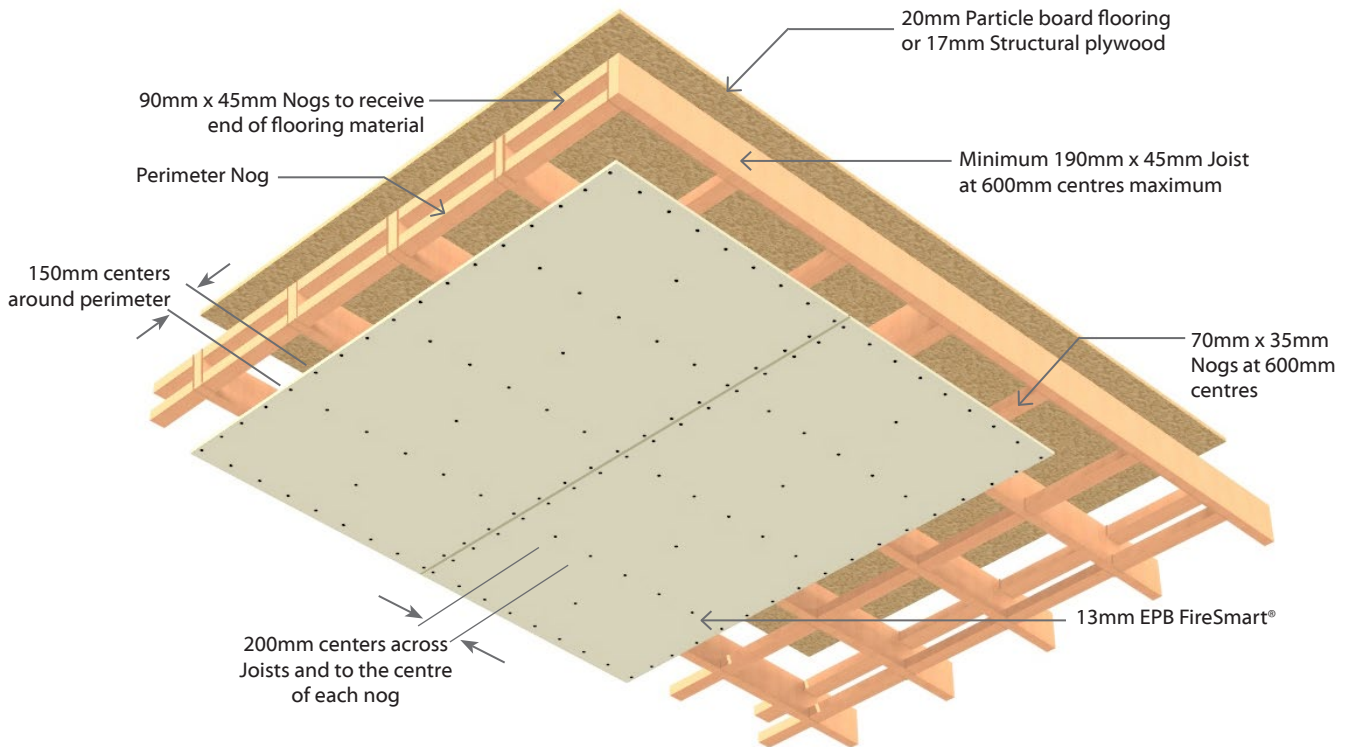

Face Paper Product Identification Code
13mm EPB FireSmart®   <b>F13</b>



**E1CJ60**

**Composite Joist Floor/Ceiling**

**Load Bearing**

**1 Layer: 1 Layer of Plasterboard to underside side of frame**

System Number	Lining Suffix	Fire Rating	Load Bearing Ability	Noise Control			Lining Requirement
				STC	Rw	IIC	
<b>E1CJ60</b>	<b>-F16</b>	60/60/60	LB	39	38	32	1 x 16mm EPB FireSmart®

**Floor Framing**

Composite Floor joists may be either hySPAN® or hyJOIST®. Joists shall be covered by specific engineering design for strength and serviceability. A minimum depth of 190mm and spaced at no more than 600mm centres.

Nogs fixed on the flat to receive the ends of flooring material shall be 90mm x 45mm minimum.

Consult the beam manufacturer re construction of the solid blocking contained in floor/ceiling to wall junctions.

**Flooring**

Minimum flooring shall be nominal 20mm thick particle board or minimum 17mm thick structural plywood, fixed to the joists as per manufacturers' instructions.

Flooring sheet joints must either be formed over framing or have a polypropylene tongue and groove jointer.

**Ceiling Framing**

Nogs fixed on the flat to receive the EPB® Plasterboard lining shall be 70mm x 45mm minimum and spaced at 600mm for joists at 600mm, or at 1200mm for joists at 400 or 450mm.

Nogs or framing is required at the perimeter of the fire rated ceiling.

**Plasterboard Lining**

**NB:** The installer must look for the Product Identification Code on the face paper to ensure the correct board type is installed. Refer to the Face Paper Product Identification Code table on this page.

One layer of 16mm EPB FireSmart® fixed at right angles directly to the underside of floor joists.

All joints must occur on joists and solid blocking.

Sheets to be touch fitted.

**Fixing of Linings Fasteners**

System number	1 <sup>st</sup> Layer
	High Thread Drywall Screws
<b>E1CJ60-F16</b>	16mm
	51 x 7g

**Fastener Centres**

Place fasteners 150mm centres around the perimeter of each sheet. 200mm centres across each joist and at the centre of each nog.

Place fasteners no closer than 12mm from sheet edges and 18mm from sheet ends.

**Wall/Ceiling Junction**

The internal angle between the ceilings and walls must be protected by Cornice or square stopped corners, taped and filled in accordance with EPB® Plasterboard Installation Guide.

**Jointing**

All fastener heads stopped and all sheet joints reinforced with paper jointing tape and stopped in accordance with the publication entitled EPB® Plasterboard Installation Guide.

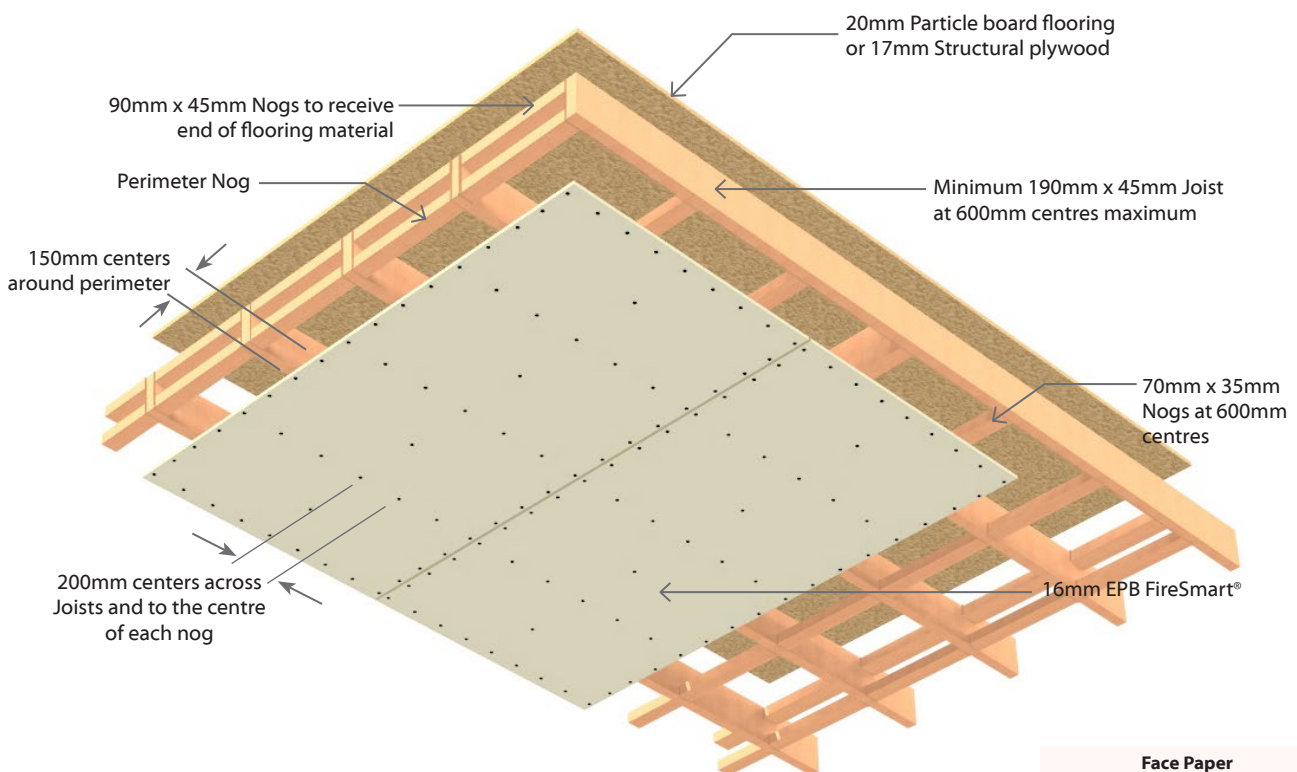

Face Paper Product Identification Code
16mm EPB FireSmart®   <b>F16</b>



**E2CJ60**

**Composite Joist Floor/Ceiling**

**Load Bearing**

**2 Layers: 2 Layers of Plasterboard to underside side of frame**

System Number	Lining Suffix	Fire Rating	Load Bearing Ability	Noise Control			Lining Requirement
				STC	Rw	IIC	
<b>E2CJ60</b>	<b>-FS26</b>	60/60/60	LB	40	39	33	1 x 13mm EPB FireSmart® and 1 x 13mm EPB® Standard

**Floor Framing**

Composite Floor joists may be either hySPAN® or hyJOIST®. Joists shall be covered by specific engineering design for strength and serviceability. A minimum depth of 190mm and spaced at no more than 600mm centres.

Nogs fixed on the flat to receive the ends of flooring material shall be 90mm x 45mm minimum.

Consult the beam manufacturer re construction of the solid blocking contained in floor/ceiling to wall junctions.

**Flooring**

Minimum flooring shall be nominal 20mm thick particle board or minimum 17mm thick structural plywood, fixed to the joists as per manufacturers' instructions.

Flooring sheet joints must either be formed over framing or have a polypropylene tongue and groove jointer.

**Ceiling Framing**

Nogs fixed on the flat to receive the EPB® Plasterboard lining shall be 70mm x 45mm minimum and spaced at 600mm for joists at 600mm, or at 1200mm for joists at 400 or 450mm.

Nogs or framing is required at the perimeter of the fire rated ceiling.

**Plasterboard Lining**

**NB:** The installer must look for the Product Identification Code on the face paper to ensure the correct board type is installed. Refer to the Face Paper Product Identification Code table on this page.

One layer of 13mm EPB FireSmart® and One layer of 13mm EPB® Standard lining fixed directly to the underside of floor joists. All joints must occur on joists and solid blocking.

All sheet joints should be staggered 600mm between layers.

Sheets shall be touch fitted.

**Fixing of Linings**

**Fasteners**

System Number	1 <sup>st</sup> Layer	2 <sup>nd</sup> Layer
	High Thread Drywall Screws	
<b>E2CJ60-FS26</b>	13mm	13mm
	41 x 6g	51 x 7g

**Fastener Centres**

Inner Layer: 150mm centres around the perimeter of each sheet, across each joist and at the centre of each nog.

Outer Layer: 150mm centres around the perimeter of each sheet and 200mm centres along each joist and at centre of each nog.

Place fasteners no closer than 12mm from sheet edges and 18mm from sheet ends.

Avoid outer layer screws from hitting inner layer screws.

**Wall/Ceiling Junction**

The internal angle between the ceilings and walls must be protected by Cornice or square stopped corners, taped and filled in accordance with EPB® Plasterboard Installation Guide.

**Jointing**

Inner Layer: Unstopped.

Outer Layer: All fastener heads stopped and all sheet joints reinforced with paper jointing tape and stopped in accordance with the publication entitled EPB® Plasterboard Installation Guide.

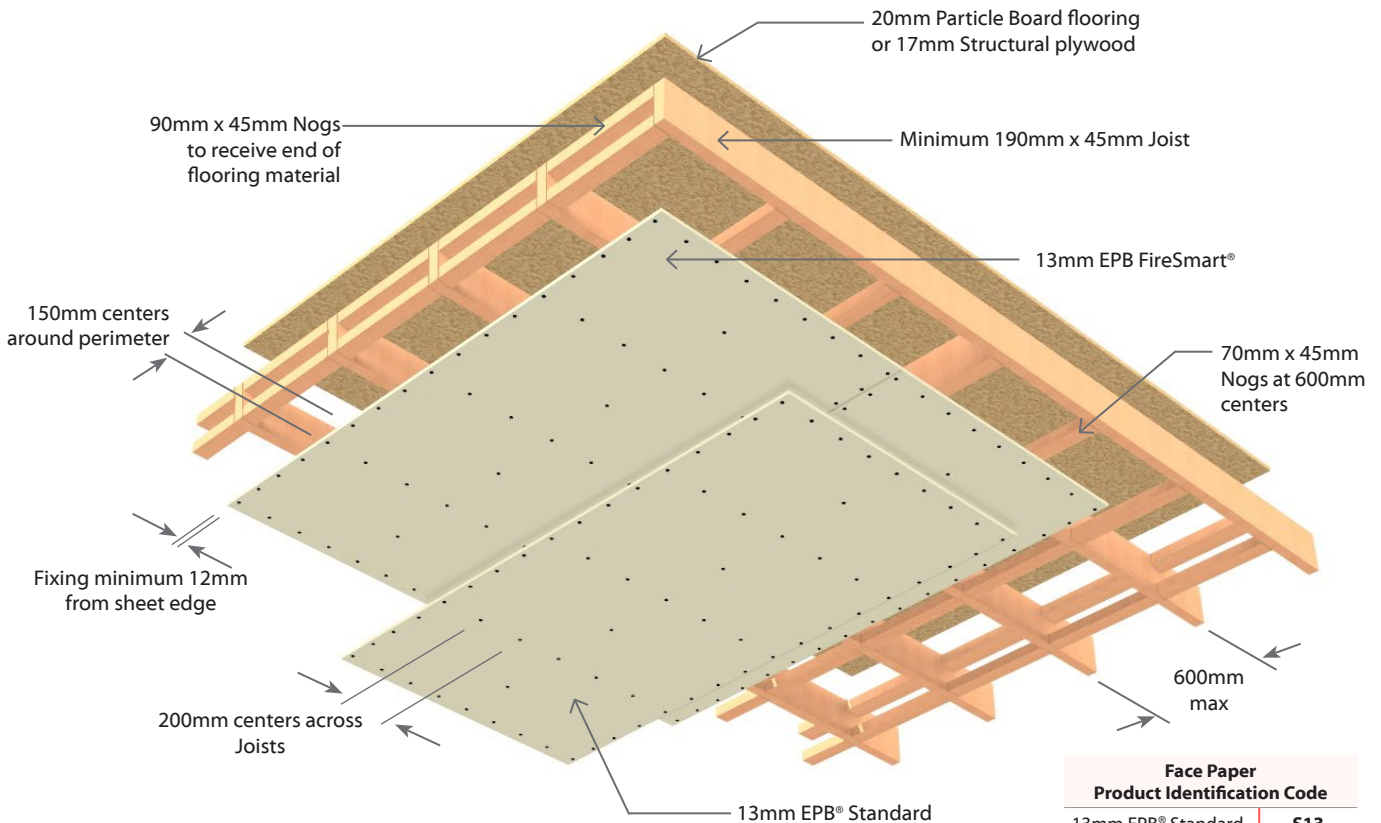

Face Paper Product Identification Code	
13mm EPB® Standard	<b>S13</b>
13mm EPB FireSmart®	<b>F13</b>



**E1SJ30**

**Steel Joists Floor/Ceiling**

**Load Bearing**

**1 Layer: 1 Layer of Plasterboard to underside side of frame**

System Number	Lining Suffix	Fire Rating	Load Bearing Ability	Noise Control			Lining Requirement
				STC	Rw	IIC	
<b>E1SJ30</b>	<b>-F13</b>	30/30/30	LB	35	34	31	1 x 13mm EPB FireSmart®

**Floor Framing**

A specifically designed steel floor structure with C-section steel floor joists of 190mm minimum depth and with 45mm flanges with a steel gauge of 1.55mm. Joist spacing's at no more than 600mm centres.

**Flooring**

Minimum flooring shall be nominal 20mm thick particle board or minimum 17mm thick structural plywood, fixed to the joists as per manufacturers' instructions.

Flooring sheet joints must either be formed over framing or have a polypropylene tongue and groove jointer.

**Ceiling Framing**

Nogs or framing are required all around the perimeter of the fire rated ceiling and on tapered edged plasterboard joints. Use perimeter framing of minimum 35mm x 35mm x 0.55mm gauge steel perimeter angle or steel nogs.

All tapered edged plasterboard joints must be supported by C-section steel nogs (connected to the joists) with a minimum width of 50mm and a vertical leg depth of 25mm and of minimum 0.55mm gauge.

**Plasterboard Lining**

**NB:** The installer must look for the Product Identification Code on the face paper to ensure the correct board type is installed. Refer to the Face Paper Product Identification Code table on this page.

One layer of 13mm EPB FireSmart® fixed at right angles directly to the underside of floor joists.

All joints must occur on joists or nogs.

Sheets to be touch fitted.

**Fixing of Linings Fasteners**

System Number	Single Layer
	Scavenger Head Drill Point Drywall Screws
<b>E1SJ30-F13</b>	13mm
	32 x 6g

**Fastener Centres**

Place fasteners 150mm centres around the perimeter of each sheet. 200mm centres along each joist.

Place fasteners no closer than 12mm from sheet edges and 18mm from sheet ends.

**Wall/Ceiling Junction**

The internal angle between the ceilings and walls must be protected by Cornice or square stopped corners, taped and filled in accordance with EPB® Plasterboard Installation Guide.

**Jointing**

All fastener heads stopped and all sheet joints reinforced with paper jointing tape and stopped in accordance with the publication entitled EPB® Plasterboard Installation Guide.

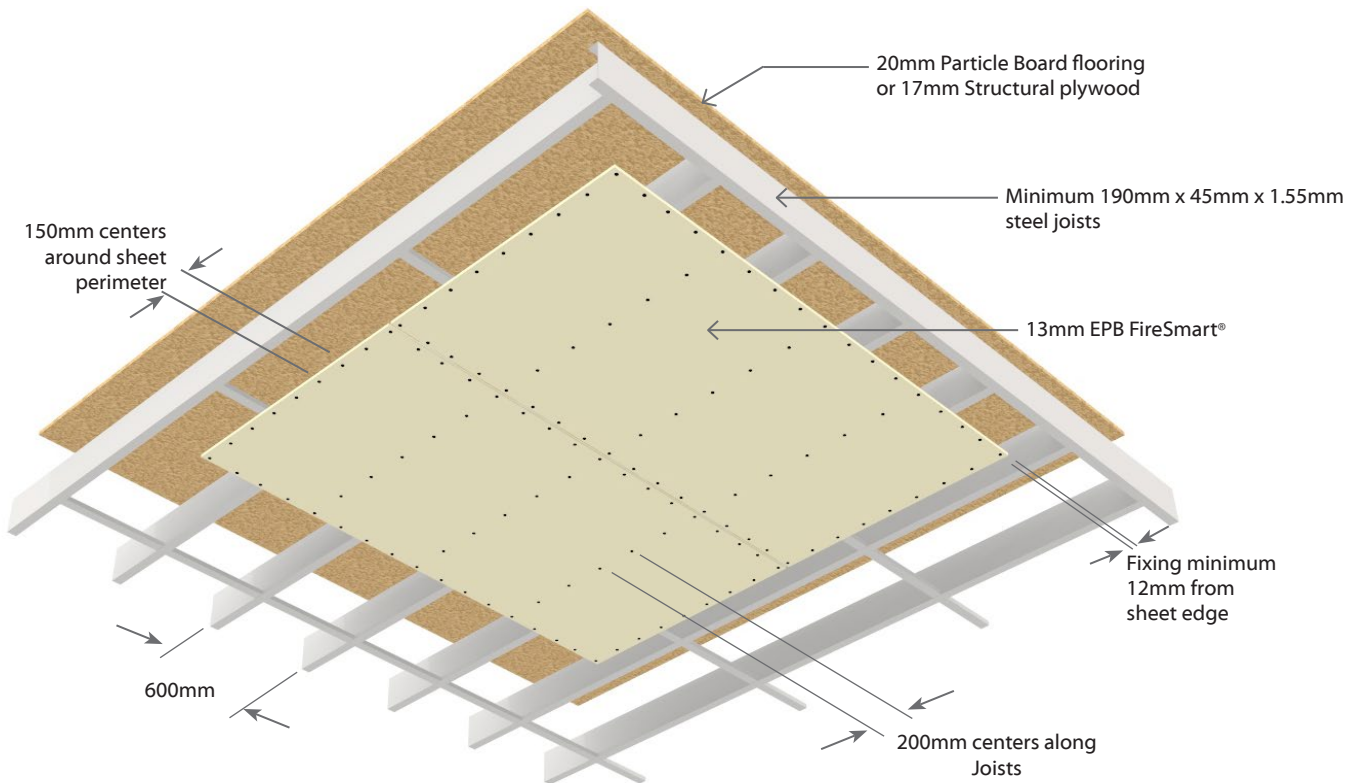

Face Paper Product Identification Code	
13mm EPB FireSmart®	<b>F13</b>



**E2SJ60**

**Steel Joists Floor/Ceiling**

**Load Bearing**

**2 Layers: 2 Layers of Plasterboard to underside side of frame**

System Number	Lining Suffix	Fire Rating	Load Bearing Ability	Noise Control			Lining Requirement
				STC	Rw	IIC	
<b>E2SJ60</b>	<b>-F26</b>	60/60/60	LB	39	38	32	2 x 13mm EPB FireSmart®

**Floor Framing**

A specifically designed steel floor structure with C-section steel floor joists of 190mm minimum depth and with 45mm flanges with a steel gauge of 1.55mm. Joist spacing's at no more than 600mm centres.

**Flooring**

Minimum flooring shall be nominal 20mm thick particle board or minimum 17mm thick structural plywood, fixed to the joists as per manufacturers' instructions.

Flooring sheet joints must either be formed over framing or have a polypropylene tongue and groove jointer.

**Ceiling Framing**

Nogs or framing are required all around the perimeter of the fire rated ceiling and on tapered edged plasterboard joints and for intermediate sheet support. Use perimeter framing of minimum 35mm x 35mm x 0.55mm gauge steel perimeter angle or steel nogs.

Use C-section steel nogs (connected to the joists) with a minimum width of 50mm and a vertical leg depth of 25mm and of minimum 0.55mm gauge. They shall be placed at maximum 600m centres to support longitudinal sheet edges and provide intermediate sheet support.

**Plasterboard Lining**

**NB:** The installer must look for the Product Identification Code on the face paper to ensure the correct board type is installed. Refer to the Face Paper Product Identification Code table on this page.

Two layers of 13mm EPB FireSmart® fixed at right angles directly to the underside of floor joists. All joints must occur on joists or nogs. All sheet joints should be staggered minimum 300mm between layers. Sheets to be touch fitted.

**Fixing of Linings Fasteners**

System Number	1 <sup>st</sup> Layer	2 <sup>nd</sup> Layer
		Scavenger Head Drill Point Drywall Screws
<b>E2SJ60-F26</b>	13mm	13mm
	32 x 6g	41 x 6g

**Fastener Centres**

Inner Layer: 150mm centres around the perimeter of each sheet, across each joist and along each nog.

Outer Layer: 150mm centres around the perimeter of each sheet and 200mm centres along each joist and along each nog.

Place fasteners 12mm from sheet edges and 18mm from sheet ends. Avoid outer layer screws from hitting inner layer screws.

**Wall/Ceiling Junction**

The internal angle between the ceilings and walls must be protected by Cornice or square stopped corners, taped and filled in accordance with EPB® Plasterboard Installation Guide.

**Jointing**

Inner Layer: Unstopped.

Outer Layer: All fastener heads stopped and all sheet joints reinforced with paper jointing tape and stopped in accordance with the publication entitled EPB® Plasterboard Installation Guide.

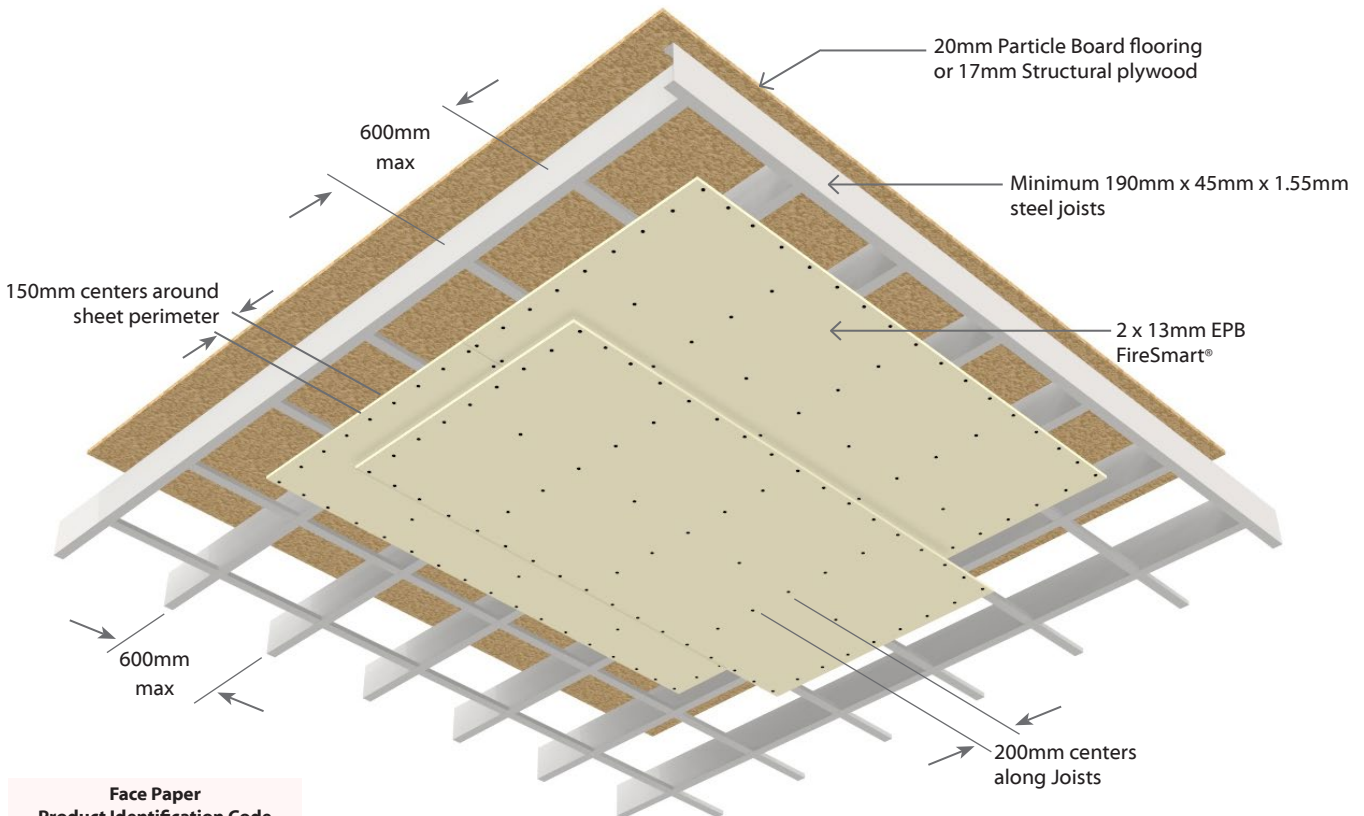

Face Paper Product Identification Code	
13mm EPB FireSmart®	<b>F13</b>



**E1BC30**

**Battened Floor/Ceiling**

**Load Bearing**

**1 Layer: 1 Layer of Plasterboard to underside side of frame**

System Number	Lining Suffix	Fire Rating	Load Bearing Ability	Noise Control			Lining Requirement
				STC	Rw	IIC	
<b>E1BC30</b>	<b>-F13</b>	30/30/30	LB	39	38	32	1 x 13mm EPB FireSmart® (back blocked)

**Floor Framing**

Timber floor joists shall comply with NZS3604 and spaced at no more than 600mm centres. Solid strutting is required in accordance with NZS 3604.

Alternatively, a proprietary I-joist system may be used subject to specific structural design and approved by the normal building consent process.

Nogs fixed on the flat to receive the ends of flooring material shall be 90mm x 45mm minimum.

**Flooring**

Flooring shall be nominal 20mm thick particle board or minimum 17mm thick structural plywood, fixed to the joists as per manufacturers' instructions.

Flooring sheet joints must either be formed over framing or have a polypropylene tongue and groove jointer.

**Ceiling Framing**

Ceiling battens to be fixed across the joists at 600mm centres maximum. Ceiling perimeter must be fully supported by framing.

**Metal Ceiling Batten:** Metal ceiling batten with minimum 35mm depth e.g. Rondo® 310.

Perimeter channels are required to receive the ends of the metal ceiling battens.

Wall angles or perimeter channels required at wall/ceiling junctions parallel to the metal ceiling battens.

**Timber Ceiling Batten:** Minimum 70mm x 35mm timber ceiling battens. Nogs or framing is required at the perimeter of the fire rated ceiling.

**Plasterboard Lining**

**NB:** The installer must look for the Product Identification Code on the face paper to ensure the correct board type is installed. Refer to the Face Paper Product Identification Code table on this page.

One layer of 13mm EPB FireSmart® fixed at right angles to the underside of the ceiling battens.

All sheet end butt joints shall occur on the battens.

Joints formed by sheet edges shall be back blocked between ceiling battens with strips of plasterboard equivalent to the lining thickness used and with a minimum width 300mm.

Sheets to be touch fitted.

**Fixing of Linings Fasteners**

System Number	Single Layer	
	Metal Ceiling Batten	Timber Ceiling Batten
	Self-Tapping Drywall Screws	High Thread Drywall Screws
<b>E1BC30-F13</b>	13mm	13mm
	25 x 6g	41 x 6g

**Fastener Centres**

Ceiling sheets shall be fixed at 200mm centres along each ceiling batten and around ceiling perimeter.

Fix butt ends at 200mm centres.

Place fasteners no closer than 12mm from sheet edges and 18mm from sheet ends.

**Wall/Ceiling Junction**

The internal angle between the ceilings and walls must be protected by Cornice or square stopped corners, taped and filled in accordance with EPB® Plasterboard Installation Guide.

**Jointing**

All fastener heads stopped and all sheet joints reinforced with paper jointing tape and stopped. All in accordance with the EPB® Plasterboard Installation Guide.



**E1BC30**

**Battened Floor/Ceiling**

**Load Bearing**

**1 Layer: 1 Layer of Plasterboard to underside side of frame**

System Number	Lining Suffix	Fire Rating	Load Bearing Ability	Noise Control			Lining Requirement
				STC	Rw	IIC	
<b>E1BC30</b>	<b>-F13</b>	30/30/30	LB	39	38	32	1 x 13mm EPB FireSmart® (back blocked)

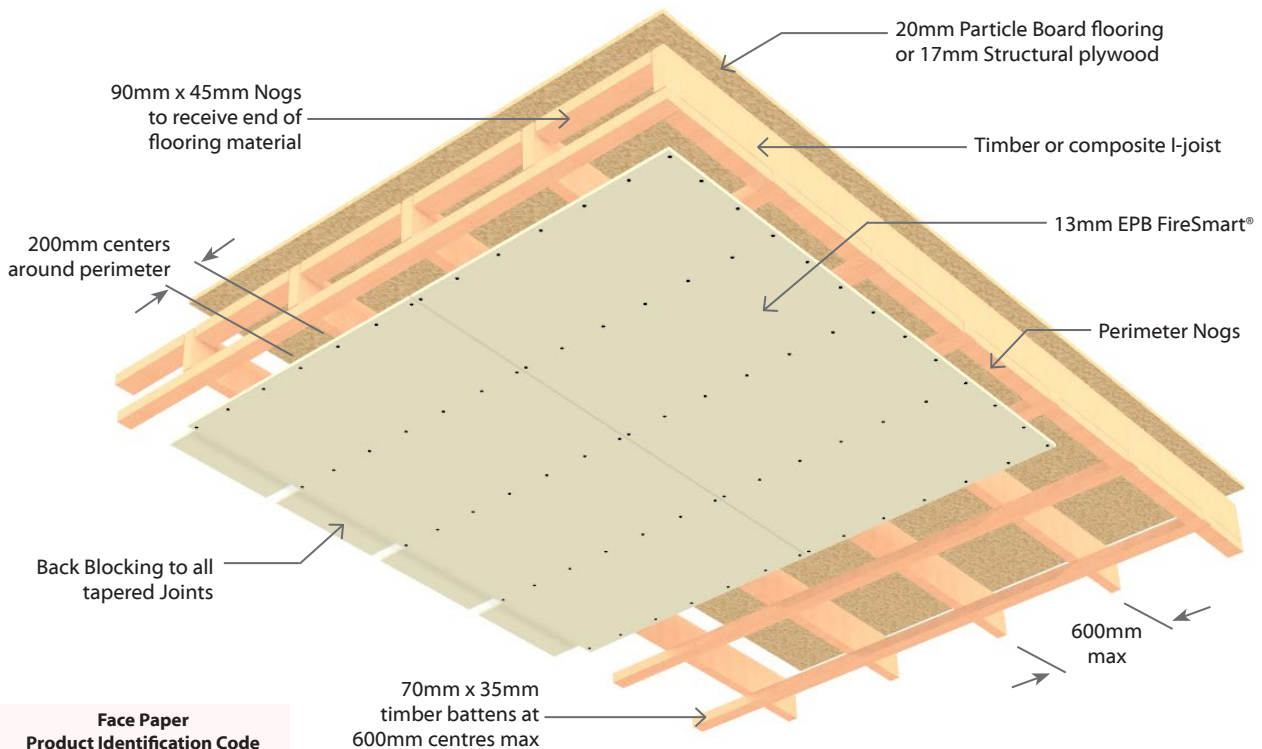
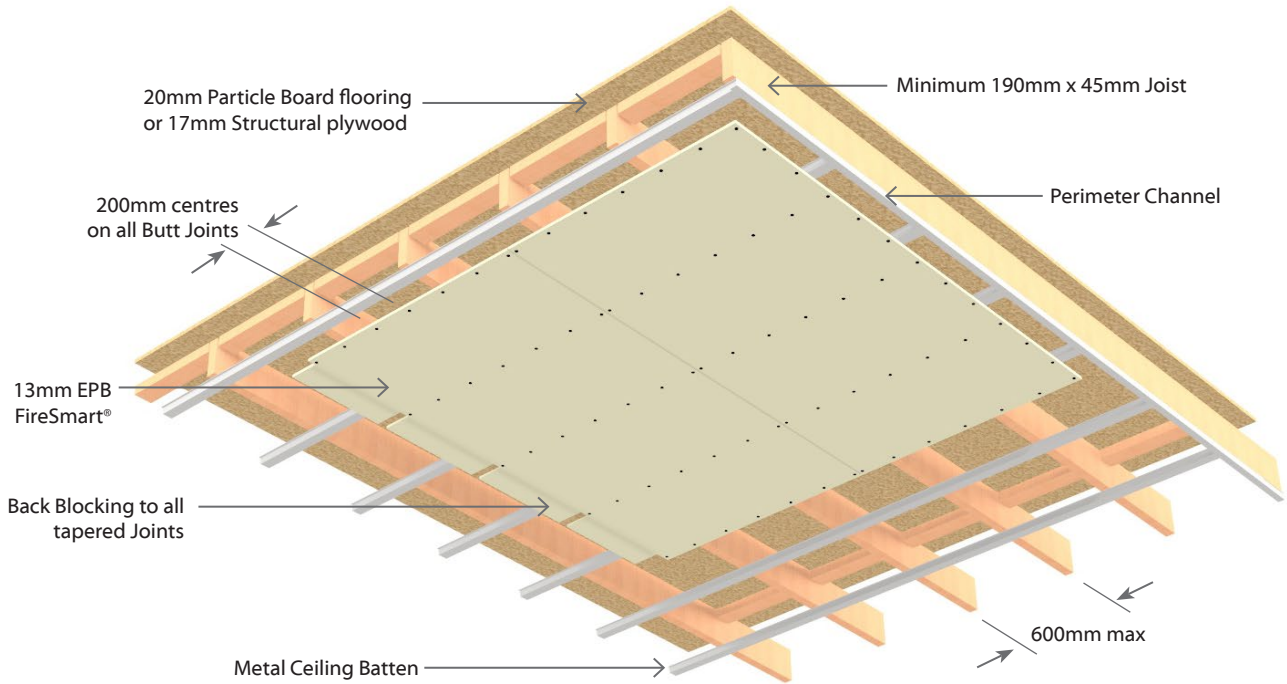

**Face Paper**  
**Product Identification Code**  
 13mm EPB FireSmart® | **F13**



**E1BC60**

**Battened Floor/Ceiling**

**Load Bearing**

**1 Layer: 1 Layer of Plasterboard to underside side of frame**

System Number	Lining Suffix	Fire Rating	Load Bearing Ability	Noise Control			Lining Requirement
				STC	Rw	IIC	
<b>E1BC60</b>	<b>-F16</b>	60/60/60	LB	39	38	32	1 x 16mm EPB FireSmart® (back blocked)

**Floor Framing**

Timber floor joists shall comply with NZS3604 with a minimum depth of 190mm x 45mm and spaced at no more than 600mm centres. Solid strutting is required in accordance with NZS 3604.

Alternatively, a proprietary I-joint system may be used subject to specific structural design and approved by the normal building consent process.

Nogs fixed on the flat to receive the ends of flooring material shall be 90mm x 45mm minimum.

**Flooring**

Flooring shall be nominal 20mm thick particle board or minimum 17mm thick structural plywood, fixed to the joists as per manufacturers' instructions.

Flooring sheet joints must either be formed over framing or have a polypropylene tongue and groove jointer.

**Ceiling Framing**

Ceiling battens to be fixed across the joists at 600mm centres maximum. Ceiling perimeter must be fully supported by framing.

**Metal Ceiling Batten:** Metal ceiling batten with minimum 35mm depth e.g. Rondo® 310.

Perimeter channels are required to receive the ends of the metal ceiling battens.

Wall angles or perimeter channels required at wall/ceiling junctions parallel to the metal ceiling battens.

**Timber Ceiling Batten:** Minimum 70mm x 35mm timber ceiling battens. Nogs or framing is required at the perimeter of the fire rated ceiling.

**Plasterboard Lining**

**NB:** The installer must look for the Product Identification Code on the face paper to ensure the correct board type is installed. Refer to the Face Paper Product Identification Code table on this page.

One layer of 16mm EPB FireSmart® fixed at right angles to the underside of the ceiling battens.

All sheet end butt joints shall occur on the battens.

Joints formed by sheet edges shall be back blocked between ceiling battens with strips of plasterboard equivalent to the lining thickness used and with a minimum width 300mm.

Sheets to be touch fitted.

**Fixing of Linings**

**Fasteners**

System Number	Single Layer	
	Metal Ceiling Batten	Timber Ceiling Batten
	Self-Tapping Drywall Screws	High Thread Drywall Screws
<b>E1BC60-F16</b>	16mm	16mm
	32 x 6g	51 x 7g

**Fastener Centres**

Ceiling sheets shall be fixed at 200mm centres along each ceiling batten and around ceiling perimeter.

Fix butt ends at 200mm centres.

Place fasteners no closer than 12mm from sheet edges and 18mm from sheet ends.

**Wall/Ceiling Junction**

The internal angle between the ceilings and walls must be protected by Cornice or square stopped corners, taped and filled in accordance with EPB® Plasterboard Installation Guide.

**Jointing**

All fastener heads stopped and all sheet joints reinforced with paper jointing tape and stopped. All in accordance with the EPB® Plasterboard Installation Guide.



**E1BC60**

**Battened Floor/Ceiling**

**Load Bearing**

**1** Layer: 1 Layer of Plasterboard to underside side of frame

System Number	Lining Suffix	Fire Rating	Load Bearing Ability	Noise Control			Lining Requirement
				STC	Rw	IIC	
<b>E1BC60</b>	<b>-F16</b>	60/60/60	LB	39	38	32	1 x 16mm EPB FireSmart® (back blocked)

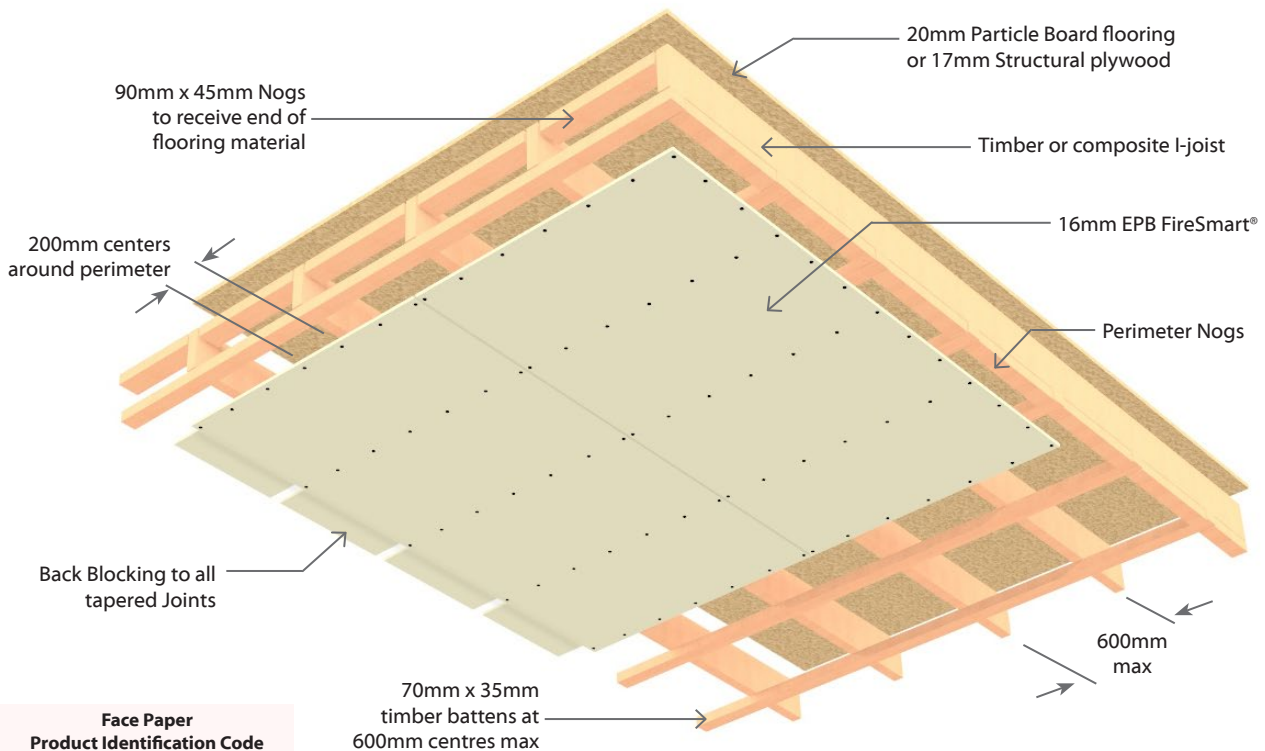
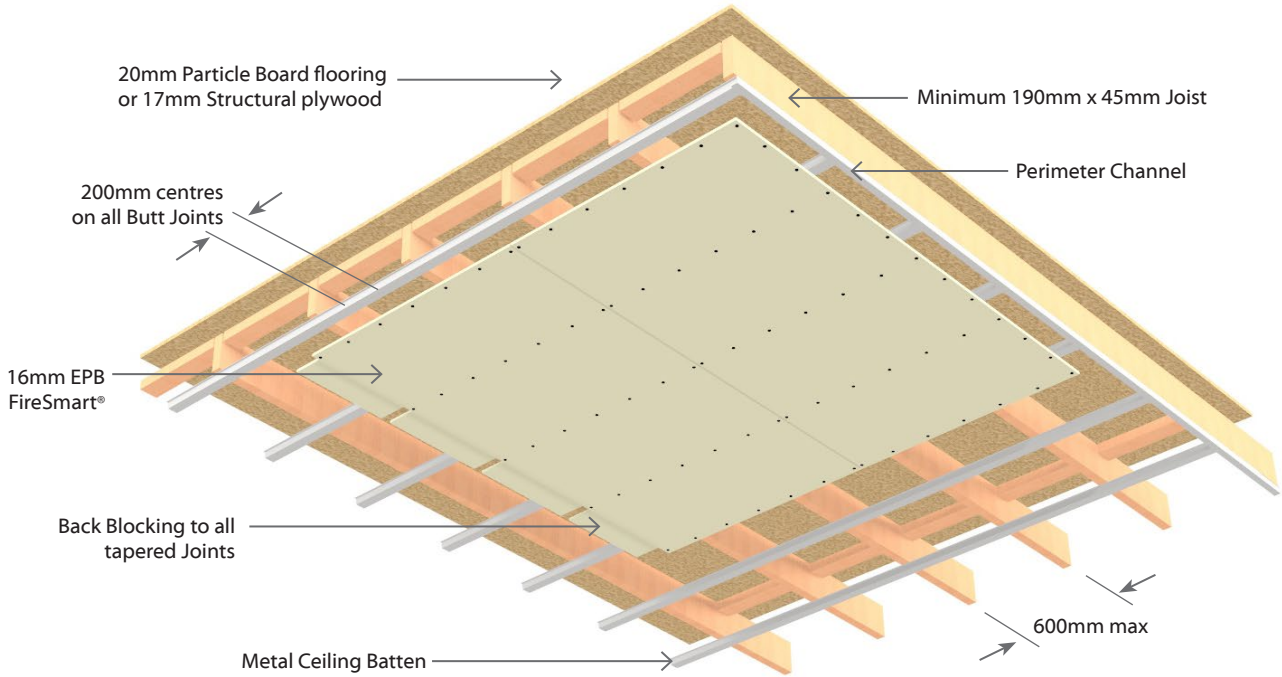

**Face Paper**  
**Product Identification Code**  
 16mm EPB FireSmart® | **F16**



**E1DF45**

**Direct Fix Clip Floor/Ceiling**

**Load Bearing**

**1 Layer: 1 Layer of Plasterboard to underside side of frame**

System Number	Lining Suffix	Fire Rating	Load Bearing Ability	Noise Control			Lining Requirement
				STC	Rw	IIC	
<b>E1DF45</b>	<b>-F13</b>	45/45/45	LB	49	48	42	1 x 13mm EPB FireSmart® (back blocked)

**Floor Framing**

Timber floor joists shall comply with NZS3604 with a minimum depth of 190mm x 45mm and spaced at no more than 600mm centres. Solid strutting is required in accordance with NZS 3604.

Nogs fixed on the flat to receive the ends of flooring material shall be 90mm x 45mm minimum.

Alternatively, a proprietary I-joist system may be used subject to specific structural design and approved by the normal building consent process. Consult the joist manufacturer regarding construction of the solid blocking contained in the floor/ceiling to wall junctions.

**Flooring**

Flooring shall be 20mm thick particle board or 17mm thick structural ply, fixed to the joists as per manufacturer's instructions.

Flooring sheet joints must either be formed over framing or have a polypropylene tongue and groove jointer.

**Clip and Battens**

Ceiling battens to be fixed across the joists at 600mm centres maximum. Ceiling perimeter must be fully supported by framing.

The Clip shall be fastened to the joists at 1200mm centres maximum (and no less than 900mm centres) to support the metal ceiling battens. They are spaced at 600mm centres maximum. Use 3 x 32mm x 8g Wafer Head screws. Insert first screw into the middle slot. Adjust clip to correct height. Then insert remaining two screws.

Perimeter channels are required to receive the ends of the metal ceiling battens.

Wall angles or perimeter channels required at wall/ceiling junctions parallel to the metal ceiling battens.

**Plasterboard Lining**

**NB:** The installer must look for the Product Identification Code on the face paper to ensure the correct board type is installed. Refer to the Face Paper Product Identification Code table on this page.

One layer of 13mm EPB FireSmart® fixed at right angles to the metal ceiling battens. All sheet end butt joints shall occur on the battens. Joints formed by sheet edges shall be back blocked between furring channels with strips of plasterboard equivalent to the lining thickness used and with a minimum width 300mm. They shall be adhered with a cove or cornice bond adhesive. Sheets shall be touch fitted.

**Fixing the Lining**

**Fasteners**

System Number	Single Layer
	Self-Tapping Drywall Screws
<b>E1DF45-F13</b>	13mm
	25 x 6g

**Fastening Centres**

Ceiling sheets shall be fixed at 200mm centres along each metal ceiling batten and around ceiling perimeter.

Fix butt ends at 100mm centres.

Place fasteners no closer than 12mm from sheet edges.

Place fasteners no closer than 18mm from sheet ends. However this can be reduced to 12mm if sheet ends occur on metal ceiling battens.

**Wall/Ceiling Junction**

The internal angle between the ceilings and walls must be protected by Cornice or square stopped corners, taped and filled in accordance with EPB® Plasterboard Installation Guide.

**Jointing**

All fastener heads stopped and all sheet joints reinforced with paper jointing tape and stopped in accordance with the publication entitled EPB® Plasterboard Installation Guide.

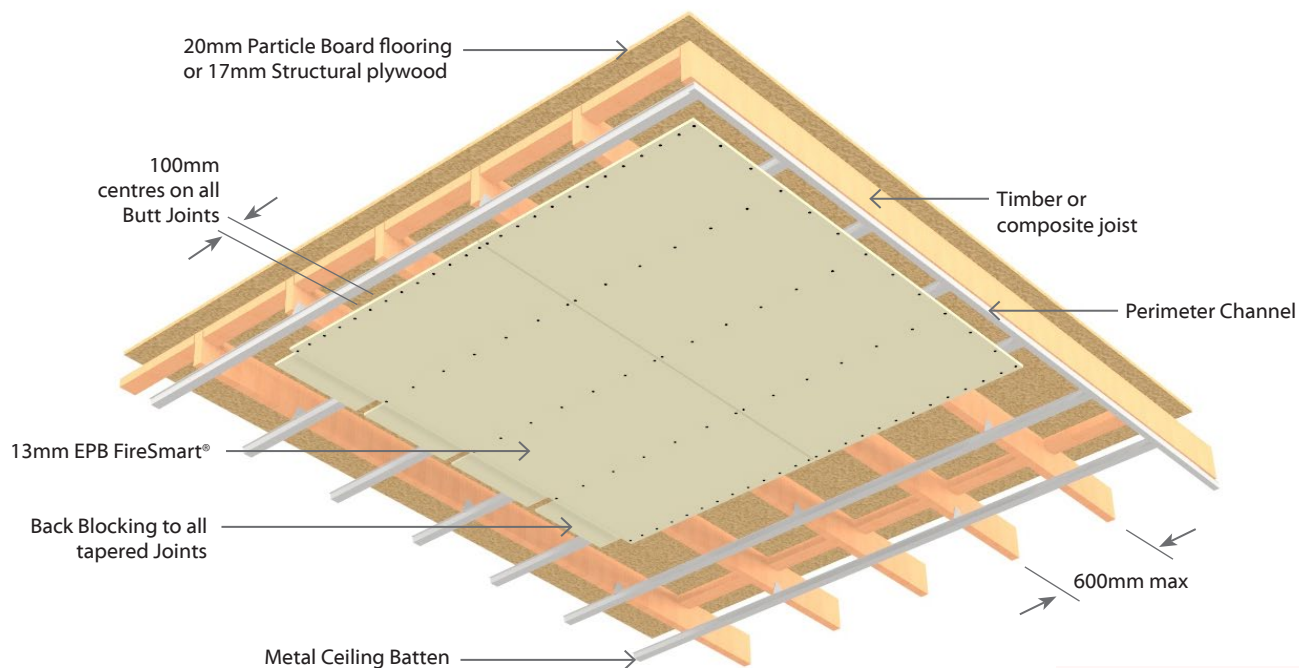

Face Paper	Product Identification Code
13mm EPB FireSmart®	<b>F13</b>



**E1DF60**

**Direct Fix Clip Floor/Ceiling**

**Load Bearing**

**1 Layer: 1 Layer of Plasterboard to underside side of frame**

System Number	Lining Suffix	Fire Rating	Load Bearing Ability	Noise Control			Lining Requirement
				STC	Rw	IIC	
<b>E1DF60</b>	<b>-F16</b>	60/60/60	LB	49	48	43	1 x 16mm EPB FireSmart® (back blocked)

**Floor Framing**

Timber floor joists shall comply with NZS3604 with a minimum depth of 190mm x 45mm and spaced at no more than 600mm centres. Solid strutting is required in accordance with NZS 3604.

Nogs fixed on the flat to receive the ends of flooring material shall be 90mm x 45mm minimum.

Alternatively, a proprietary I-joist system may be used subject to specific structural design and approved by the normal building consent process. Consult the joist manufacturer regarding construction of the solid blocking contained in the floor/ceiling to wall junctions.

**Flooring**

Flooring shall be 20mm thick particle board or 17mm thick structural ply, fixed to the joists as per manufacturer's instructions.

Flooring sheet joints must either be formed over framing or have a polypropylene tongue and groove jointer.

**Clip and Battens**

Ceiling battens to be fixed across the joists at 600mm centres maximum. Ceiling perimeter must be fully supported by framing.

The Clip shall be fastened to the joists at 1200mm centres maximum (and no less than 900mm centres) to support the metal ceiling battens. They are spaced at 600mm centres maximum. Use 3 x 32mm x 8g Wafer Head screws. Insert first screw into the middle slot. Adjust clip to correct height. Then insert remaining two screws.

Perimeter channels are required to receive the ends of the metal ceiling battens.

Wall angles or perimeter channels required at wall/ceiling junctions parallel to the metal ceiling battens.

**Plasterboard Lining**

**NB:** The installer must look for the Product Identification Code on the face paper to ensure the correct board type is installed. Refer to the Face Paper Product Identification Code table on this page.

One layer of 16mm EPB FireSmart® fixed at right angles to the metal ceiling battens. All sheet end butt joints shall occur on the battens. Joints formed by sheet edges shall be back blocked between furring channels with strips of plasterboard equivalent to the lining thickness used and with a minimum width 300mm. They shall be adhered with a cove or cornice bond adhesive. Sheets shall be touch fitted.

**Fixing the Lining**

**Fasteners**

System Number	Single Layer
	Self-Tapping Drywall Screws
<b>E1DF60-F16</b>	16mm
	32 x 6g

**Fastening Centres**

Ceiling sheets shall be fixed at 200mm centres along each metal ceiling batten and around ceiling perimeter.

Fix butt ends at 100mm centres.

Place fasteners no closer than 12mm from sheet edges.

Place fasteners no closer than 18mm from sheet ends. However this can be reduced to 12mm if sheet ends occur on metal ceiling battens

**Wall/Ceiling Junction**

The internal angle between the ceilings and walls must be protected by Cornice or square stopped corners, taped and filled in accordance with EPB® Plasterboard Installation Guide.

**Jointing**

All fastener heads stopped and all sheet joints reinforced with paper jointing tape and stopped in accordance with the publication entitled EPB® Plasterboard Installation Guide.

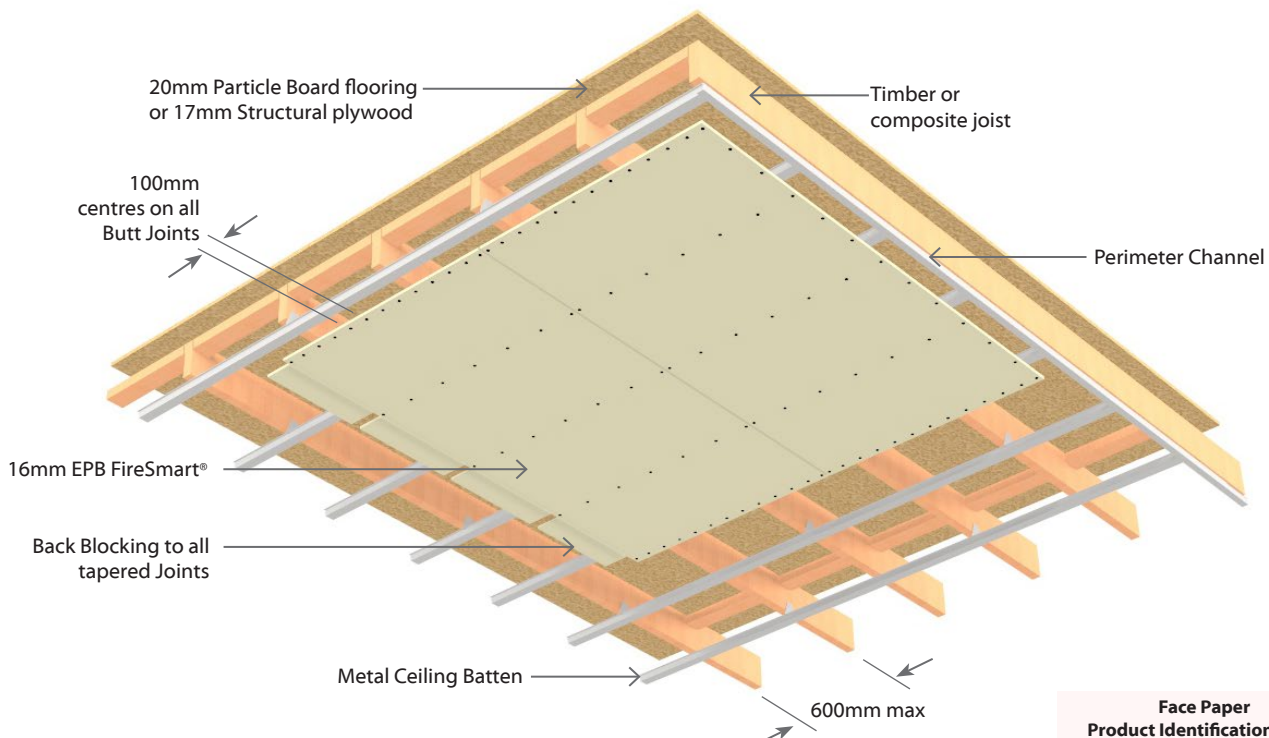

Face Paper Product Identification Code
16mm EPB FireSmart®   <b>F16</b>



**E2DF60**

**Direct Fix Clip Floor/Ceiling**

**Load Bearing**

**2 Layers: 2 Layers of Plasterboard to underside side of frame**

System Number	Lining Suffix	Fire Rating	Load Bearing Ability	Noise Control			Lining Requirement
				STC	Rw	IIC	
<b>E2DF60</b>	<b>-FS26</b>	60/60/60	LB	49	48	43	1 x 13mm EPB FireSmart® and 1 x 13mm EPB® Standard
	<b>-F26</b>	60/60/60	LB	52	51	43	2 x 13mm EPB FireSmart®

**Floor Framing**

Timber floor joists shall comply with NZS3604 with a minimum depth of 190mm x 45mm and spaced at no more than 600mm centres. Solid strutting is required in accordance with NZS 3604.

Nogs fixed on the flat to receive the ends of flooring material shall be 90mm x 45mm minimum.

Alternatively, a proprietary I-joist system may be used subject to specific structural design and approved by the normal building consent process. Consult the joist manufacturer regarding construction of the solid blocking contained in the floor/ceiling to wall junctions.

**Flooring**

Flooring shall be 20mm thick particle board or 17mm thick structural ply, fixed to the joists as per manufacturer's instructions.

Flooring sheet joints must either be formed over framing or have a polypropylene tongue and groove jointer.

**Clip and Battens**

The Clip shall be fastened to the joists at 1200mm centres maximum (and no less than 900mm centres) to support the metal ceiling battens. They are spaced at 600mm centres maximum. Use 3 x 32mm x 8g Wafer Head screws. Insert first screw into the middle slot. Adjust clip to correct height. Then insert remaining two screws.

Perimeter channels are required to receive the ends of the metal ceiling battens.

Wall angles or perimeter channels required at wall/ceiling junctions parallel to the metal ceiling battens.

**Plasterboard Lining**

**NB:** The installer must look for the Product Identification Code on the face paper to ensure the correct board type is installed. Refer to the Face Paper Product Identification Code table on this page.

Two layers of 13mm EPB® Plasterboard as per specified system above fixed at right angles to the metal ceiling battens. All sheet end butt joints shall occur on the battens. Offset the outer layer by 600mm from the inner layer. Sheet joints shall be touch fitted.

**Fixing the Lining**

**Fasteners**

System Number	1 <sup>st</sup> Layer	2 <sup>nd</sup> Layer
	Self-Tapping Drywall Screws	
<b>E2DF60-FS26</b>	13mm	13mm
<b>E2DF60-F26</b>	25 x 6g	41 x 6g

**Fastening Centres**

Ceiling sheets shall be fixed at 200mm centres along each metal ceiling batten and around ceiling perimeter.

Fix butt ends at 100mm centres.

Place fasteners no closer than 12mm from sheet edges.

Place fasteners no closer than 18mm from sheet ends. However this can be reduced to 12mm if sheet ends occur on metal ceiling battens.

Avoid outer layer screws from hitting inner layer screws.

**Wall/Ceiling Junction**

The internal angle between the ceilings and walls must be protected by Cornice or square stopped corners, taped and filled in accordance with EPB® Plasterboard Installation Guide.

**Jointing**

Inner layer: Unstopped.

Outer Layer: All fastener heads stopped and all sheet joints reinforced with paper jointing tape and stopped in accordance with the publication entitled EPB® Plasterboard Installation Guide.

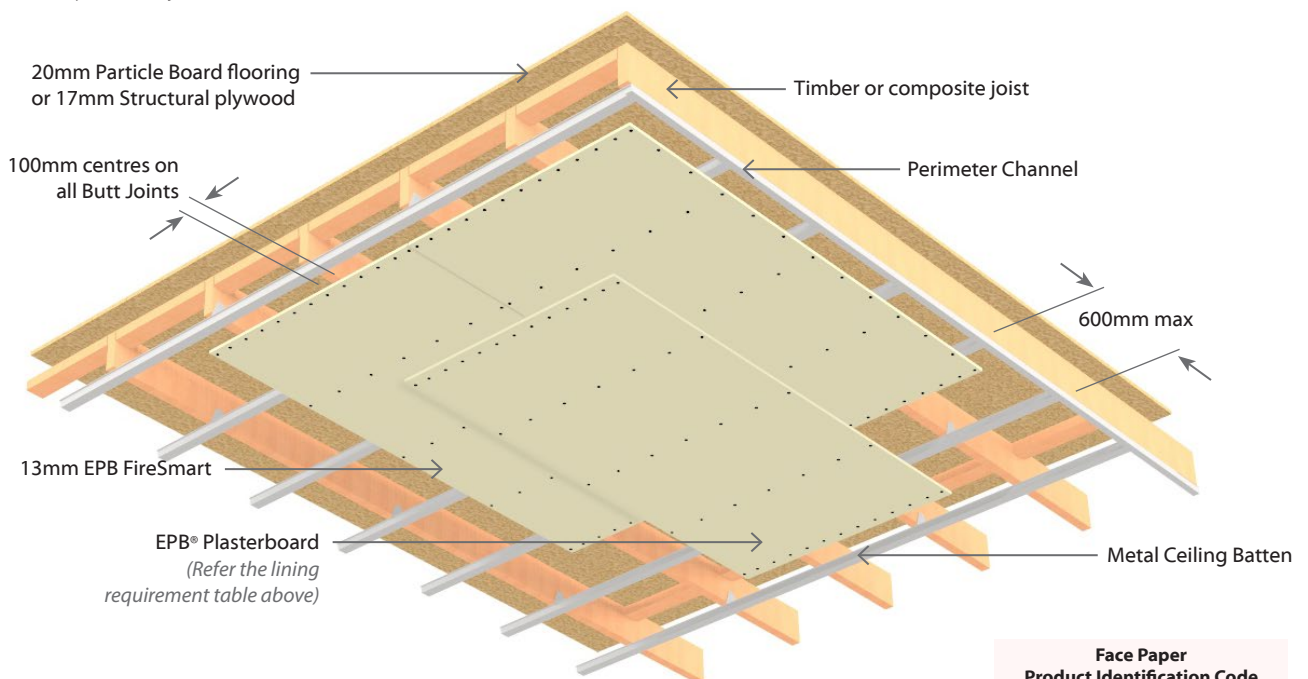

Face Paper Product Identification Code	
13mm EPB® Standard	<b>S13</b>
13mm EPB FireSmart®	<b>F13</b>



**E2DF90**

**Direct Fix Clip Floor/Ceiling**

**Load Bearing**

**2 Layers: 2 Layers of Plasterboard to underside side of frame**

System Number	Lining Suffix	Fire Rating	Load Bearing Ability	Noise Control			Lining Requirement
				STC	Rw	IIC	
<b>E2DF90</b>	<b>-F32</b>	90/90/90	LB	54	53	43	2 x 16mm EPB FireSmart®

**Floor Framing**

Timber floor joists shall comply with NZS3604 with a minimum depth of 190mm x 45mm and spaced at no more than 600mm centres. Solid strutting is required in accordance with NZS 3604.

Nogs fixed on the flat to receive the ends of flooring material shall be 90mm x 45mm minimum.

**Flooring**

Flooring shall be 20mm thick particle board or 17mm thick structural ply, fixed to the joists as per manufacturer's instructions.

Flooring sheet joints must either be formed over framing or have a polypropylene tongue and groove jointer.

**Clip and Battens**

The Clip shall be fastened to the joists at 1200mm centres maximum (and no less than 900mm centres) to support the metal ceiling battens. They are spaced at 600mm centres maximum. Use 3 x 32mm x 8g Wafer Head screws. Insert first screw into the middle slot. Adjust clip to correct height. Then insert remaining two screws.

Perimeter channels are required to receive the ends of the metal ceiling battens.

Wall angles or perimeter channels required at wall/ceiling junctions parallel to the metal ceiling battens.

**Plasterboard Lining**

**NB:** The installer must look for the Product Identification Code on the face paper to ensure the correct board type is installed. Refer to the Face Paper Product Identification Code table on this page.

Two layers of 16mm EPB FireSmart® fixed at right angles to the metal ceiling battens. All sheet end butt joints shall occur on the battens. Offset the outer layer by 600mm from the inner layer. Sheet joints shall be touch fitted.

**Fixing the Lining**

**Fasteners**

System Number	1 <sup>st</sup> Layer	2 <sup>nd</sup> Layer
	Self-Tapping Drywall Screws	
<b>E2DF90-F32</b>	16mm	16mm
	32 x 6g	51 x 7g

**Fastening Centres**

Ceiling sheets shall be fixed at 200mm centres along each metal ceiling batten and around ceiling perimeter.

Fix butt ends at 100mm centres.

Place fasteners no closer than 12mm from sheet edges.

Place fasteners no closer than 18mm from sheet ends. However this can be reduced to 12mm if sheet ends occur on metal ceiling battens.

Avoid outer layer screws from hitting inner layer screws.

**Wall/Ceiling Junction**

The internal angle between the ceilings and walls must be protected by Cornice or square stopped corners, taped and filled in accordance with EPB® Plasterboard Installation Guide.

**Jointing**

Inner layer: Unstopped.

Outer Layer: All fastener heads stopped and all sheet joints reinforced with paper jointing tape and stopped in accordance with the publication entitled EPB® Plasterboard Installation Guide.

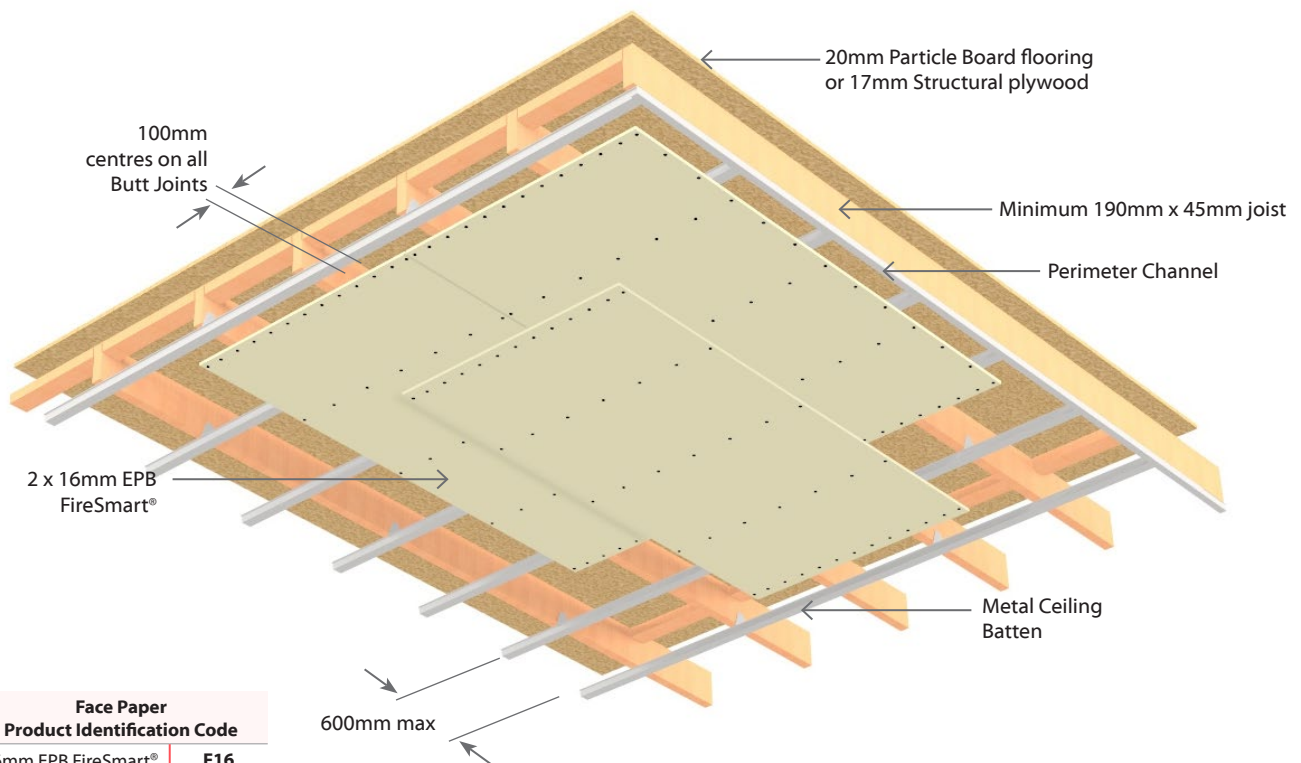

Face Paper Product Identification Code	
16mm EPB FireSmart®	<b>F16</b>



**E2SC30**

**Suspended Grid Floor/Ceiling**

**Load Bearing**

**2 Layers: 2 Layers of Plasterboard to underside side of frame**

System Number	Lining Suffix	Fire Rating	Load Bearing Ability	Noise Control			Lining Requirement
				STC	Rw	IIC	
<b>E2SC30</b>	<b>-S26</b>	30/30/30	LB	50	49	42	2 x 13mm EPB® Standard

**Floor Framing**

Timber floor joists shall comply with NZS3604 and spaced at no more than 600mm centres. Solid strutting is required in accordance with NZS 3604.

Alternatively, a proprietary I-joist system may be used subject to specific structural design and approved by the normal building consent process.

Nogs fixed on the flat to receive the ends of flooring material shall be 90mm x 45mm minimum.

**Flooring**

Flooring shall be 20mm thick particle board or 17mm thick structural ply, fixed to the joists as per manufacturer's instructions.

Flooring sheet joints must either be formed over framing or have a polypropylene tongue and groove jointer.

**Suspension System**

Rondo® KEY-LOCK™ steel frame suspension system comprising 2.5mm wire hangers at 1200mm centres supporting top cross rails (part 128) spaced at a maximum of 1200mm centres and furring channels (part 129) at 600mm centres.

OR

Rondo ScrewFix® steel frame suspension system comprising 2.5mm wire hangers at 1200mm centres supporting F38 strong back channels spaced at a maximum of 1200mm centres and F37 furring channels at 600mm centres.

OR

Alternative suspension systems with equivalent performance characteristics and layout may be used.

Suspended Grid ceiling system to be installed as per manufacturer's specification.

**Plasterboard Lining**

**NB:** The installer must look for the Product Identification Code on the face paper to ensure the correct board type is installed. Refer to the Face Paper Product Identification Code table on this page.

Two layers of 13mm EPB® Standard, fixed perpendicular to the furring channels. Offset the joints of the outer layer by 600mm from those of the inner layer.

All sheet butt joints must occur on the furring channel. Sheet joints shall be touch fitted.

**Fixing of Linings**

**Fasteners (As per Specified System Above)**

System Number	1 <sup>st</sup> Layer	2 <sup>nd</sup> Layer
		Self-Tapping Drywall Screws
<b>E2SC30-S26</b>	13mm	13mm
	25 x 6g	41 x 6g

**Fastener Centres**

Ceiling sheets shall be fixed at 200mm centres along each furring channel, around the ceiling perimeter and at 200mm centres where butt joints occur.

Place fasteners no closer than 12mm from sheet edges.

Place fasteners no closer than 18mm from sheet ends. However this can be reduced to 12mm if sheet ends occur on furring channels.

Avoid outer layer screws from hitting inner layer screws.

**Wall/Ceiling Junction**

The internal angle between the ceilings and walls must be protected by Cornice or square stopped corners, taped and filled in accordance with EPB® Plasterboard Installation Guide.

**Jointing**

Inner layer: Unstopped.

Outer Layer: All fastener heads stopped and all sheet joints reinforced with paper jointing tape and stopped in accordance with the publication entitled EPB® Plasterboard Installation Guide.

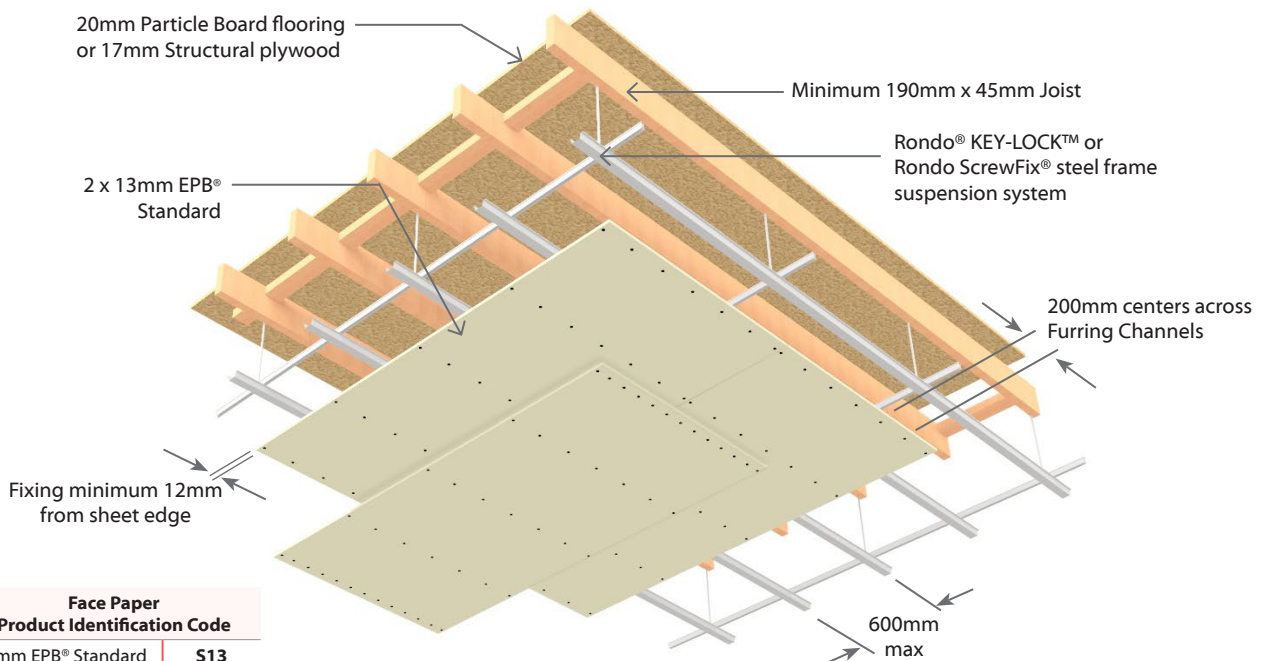

Face Paper Product Identification Code	
13mm EPB® Standard	<b>S13</b>



**E1SC45**

**Suspended Grid Floor/Ceiling**

**Load Bearing**

**1 Layer: 1 Layer of Plasterboard to underside side of frame**

System Number	Lining Suffix	Fire Rating	Load Bearing Ability	Noise Control			Lining Requirement
				STC	Rw	IIC	
<b>E1SC45</b>	<b>-F13</b>	45/45/45	LB	48	47	42	1 x 13mm EPB FireSmart® (back blocked)

**Floor Framing**

Timber floor joists shall comply with NZS3604 and spaced at no more than 600mm centres. Solid strutting is required in accordance with NZS 3604.

Alternatively, a proprietary I-joint system may be used subject to specific structural design and approved by the normal building consent process.

Nogs fixed on the flat to receive the ends of flooring material shall be 90mm x 45mm minimum.

**Flooring**

Flooring shall be 20mm thick particle board or 17mm thick structural ply, fixed to the joists as per manufacturer's instructions.

Flooring sheet joints must either be formed over framing or have a polypropylene tongue and groove jointer.

**Suspension System**

Rondo® KEY-LOCK™ steel frame suspension system comprising 2.5mm wire hangers at 1200mm centres supporting top cross rails (part 128) spaced at a maximum of 1200mm centres and (part 129) furring channels at 600mm centres.

OR

Rondo ScrewFix® steel frame suspension system comprising 2.5mm wire hangers at 1200mm centres supporting F38 strong back channels spaced at a maximum of 1200mm centres and F37 furring channels at 600mm centres.

OR

Alternative suspension systems with equivalent performance characteristics and layout may be used.

Suspended Grid ceiling system to be installed as per manufacturer's specification.

**Plasterboard Lining**

**NB:** The installer must look for the Product Identification Code on the face paper to ensure the correct board type is installed. Refer to the Face Paper Product Identification Code table on this page.

One layer of 13mm EPB FireSmart® fixed at right angles to the furring channels. All sheet butt joints must occur on the furring channel. Joints formed by sheet edges shall be back blocked between furring channels with strips of plasterboard equivalent to the lining thickness used and with a minimum width 300mm. They shall be adhered with a cove or cornice bond adhesive.

Sheet joints shall be touch fitted.

**Fixing the Lining**

**Fasteners**

System Number	Single Layer
	Self-Tapping Drywall Screw
<b>E1SC45-F13</b>	13mm
	25 x 6g

**Fastening Centres**

Ceiling sheets shall be fixed at 200mm centres along each furring channel, around the ceiling perimeter and at 200mm centres where butt joints occur.

Place fasteners no closer than 12mm from sheet edges.

Place fasteners no closer than 18mm from sheet ends. However this can be reduced to 12mm if sheet ends occur on furring channels.

**Wall/Ceiling Junction**

The internal angle between the ceilings and walls must be protected by Cornice or square stopped corners, taped and filled in accordance with EPB® Plasterboard Installation Guide.

**Jointing**

All fastener heads stopped and all sheet joints reinforced with paper jointing tape and stopped in accordance with the publication entitled EPB® Plasterboard Installation Guide.

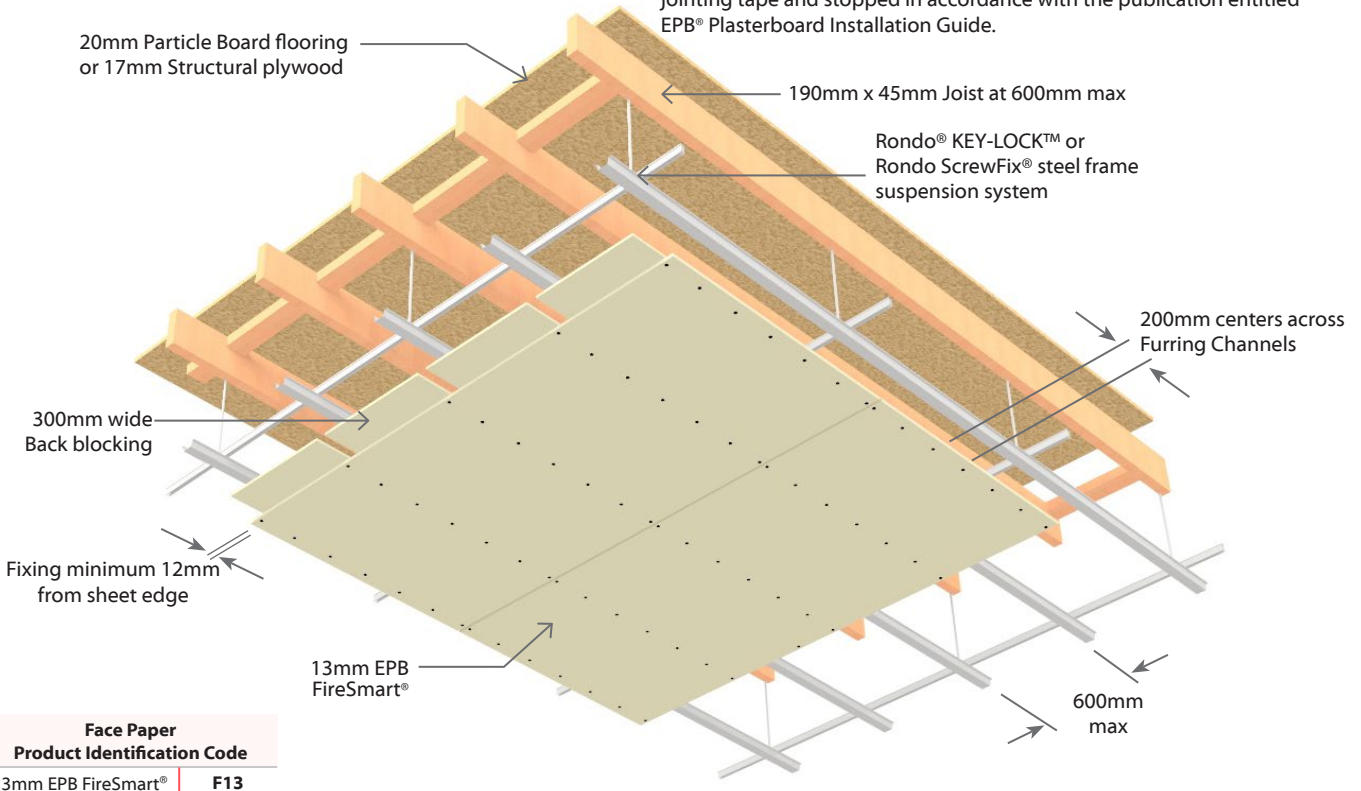

**E1SC60**

**Suspended Grid Floor/Ceiling**

**Load Bearing**

**1 Layer: 1 Layer of Plasterboard to underside side of frame**

System Number	Lining Suffix	Fire Rating	Load Bearing Ability	Noise Control			Lining Requirement
				STC	Rw	IIC	
<b>E1SC60</b>	<b>-F16</b>	60/60/60	LB	48	47	43	1 x 16mm EPB FireSmart® (back blocked)

**Floor Framing**

Timber floor joists shall comply with NZS3604 and spaced at no more than 600mm centres. Solid strutting is required in accordance with NZS 3604.

Alternatively, a proprietary I-joist system may be used subject to specific structural design and approved by the normal building consent process.

Nogs fixed on the flat to receive the ends of flooring material shall be 90mm x 45mm minimum.

**Flooring**

Flooring shall be 20mm thick particle board or 17mm thick structural ply, fixed to the joists as per manufacturer's instructions.

Flooring sheet joints must either be formed over framing or have a polypropylene tongue and groove jointer.

**Suspension System**

Rondo® KEY-LOCK™ steel frame suspension system comprising 2.5mm wire hangers at 1200mm centres supporting top cross rails (part 128) spaced at a maximum of 1200mm centres and furring channels (part 129) at 600mm centres.

OR

Rondo ScrewFix® steel frame suspension system comprising 2.5mm wire hangers at 1200mm centres supporting F38 strong back channels spaced at a maximum of 1200mm centres and F37 furring channels at 600mm centres.

OR

Alternative suspension systems with equivalent performance characteristics and layout may be used.

Suspended Grid ceiling system to be installed as per manufacturer's specification.

**Plasterboard Lining**

**NB:** The installer must look for the Product Identification Code on the face paper to ensure the correct board type is installed. Refer to the Face Paper Product Identification Code table on this page.

One layer of 16mm EPB FireSmart® fixed at right angles to the furring channels. All sheet butt joints must occur on the furring channel.

Joints formed by sheet edges shall be back blocked between furring channels with strips of plasterboard equivalent to the lining thickness used and with a minimum width 300mm. They shall be adhered with a cove or cornice bond adhesive.

Sheet joints shall be touch fitted.

**Fixing the Lining**

**Fasteners**

System Number	Single Layer
	Self-Tapping Drywall Screw
<b>E1SC60-F16</b>	16mm
	32 x 6g

**Fastening Centres**

Ceiling sheets shall be fixed at 200mm centres along each furring channel, around the ceiling perimeter and at 150mm centres where butt joints occur.

Place fasteners no closer than 12mm from sheet edges.

Place fasteners no closer than 18mm from sheet ends. However this can be reduced to 12mm if sheet ends occur on furring channels.

**Wall/Ceiling Junction**

The internal angle between the ceilings and walls must be protected by Cornice or square stopped corners, taped and filled in accordance with EPB® Plasterboard Installation Guide.

**Jointing**

All fastener heads stopped and all sheet joints reinforced with paper jointing tape and stopped in accordance with the publication entitled EPB® Plasterboard Installation Guide.

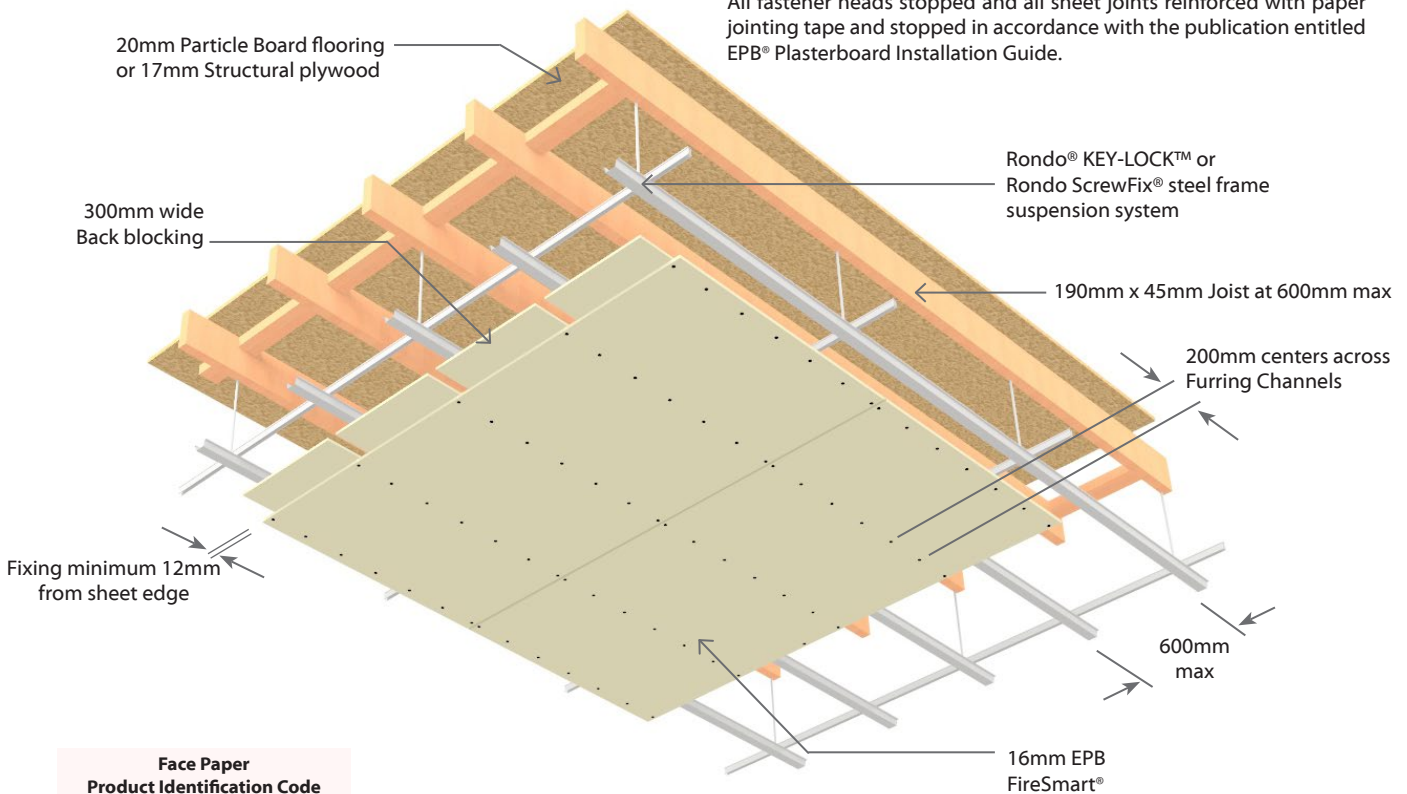

**E1XC60**

Suspended Rondo Express® Grid Ceiling System

Load Bearing

**1 Layer:** 1 Layer of Plasterboard to underside side of frame

System Number	Lining Suffix	Fire Rating	Load Bearing Ability	Noise Control			Lining Requirement
				STC	Rw	IIC	
<b>E1XC60</b>	<b>-F16</b>	60/60/60	LB	48	47	43	1 x 16mm EPB FireSmart®

**Floor Framing**

Timber floor joists shall comply with NZS3604 and spaced at no more than 600mm centres. Solid strutting is required in accordance with NZS 3604.

Alternatively, a proprietary I-joist system may be used subject to specific structural design and approved by the normal building consent process.

Nogs fixed on the flat to receive the ends of flooring material shall be 90mm x 45mm minimum.

**Flooring**

Flooring shall be 20mm thick particle board or 17mm thick structural ply, fixed to the joists as per manufacturer's instructions.

Flooring sheet joints must either be formed over framing or have a polypropylene tongue and groove jointer.

**Minimum Cavity Depth**

The system requires a minimum of 450mm cavity depth between the ceiling linings and the underside of the flooring.

**Suspension System**

Rondo Express® Drywall Grid ceiling system comprising 2.5mm wire hangers or Rondo XD50 wall angles at 1200mm centres maximum, supporting Rondo XD1 main tee spaced at a maximum of 1200mm centres and Rondo XD2-1200 cross tee installed at 600mm centres. Install Rondo XD2-600 cross tees at 1200mm centres, parallel to the main tee.

Rondo Express® Drywall Grid ceiling system to be installed as per manufacturer's specification.

**Plasterboard Lining**

**NB:** The installer must look for the Product Identification Code on the face paper to ensure the correct board type is installed. Refer to the Face Paper Product Identification Code table on this page.

One layer of 16mm EPB FireSmart® fixed parallel to the main tees. All taper edges must be located on cross tees. All sheet butt joints must occur on the suspension system.

Sheet joints shall be touch fitted.

**Fixing the Lining**

**Fasteners**

System Number	Single Layer
	Self-Tapping Drywall Screw
<b>E1XC60-F16</b>	16mm
	32 x 6g

**Fastening Centres**

Ceiling sheets shall be fixed at 150mm centres around each sheet perimeter and 200mm centres to intermediate framing. Place fasteners no closer than 12mm from sheet edges.

Place fasteners no closer than 18mm from sheet ends. However this can be reduced to 12mm if sheet ends occur on cross tees.

**Wall/Ceiling Junction**

The internal angle between the ceilings and walls must be protected by Cornice or square stopped corners, taped and filled in accordance with EPB® Plasterboard Installation Guide.

**Jointing**

All fastener heads stopped and all sheet joints reinforced with paper jointing tape and stopped in accordance with the publication entitled EPB® Plasterboard Installation Guide.

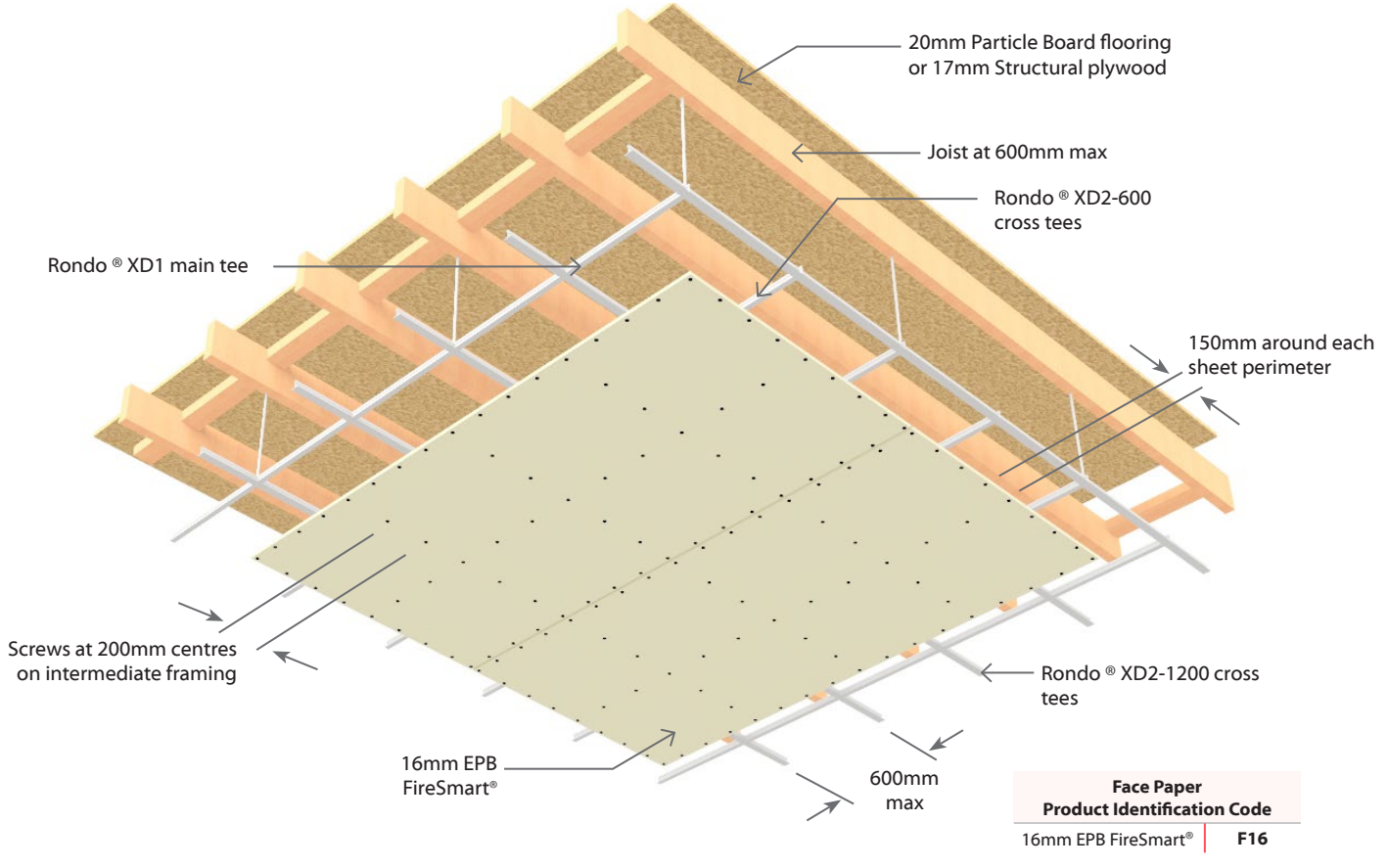

**E2SC60**

**Suspended Grid Floor/Ceiling**

**Load Bearing**

**2** Layers: 2 Layers of Plasterboard to underside side of frame

System Number	Lining Suffix	Fire Rating	Load Bearing Ability	Noise Control			Lining Requirement
				STC	Rw	IIC	
<b>E2SC60</b>	<b>-FS26</b>	60/60/60	LB	48	47	42	1 x 13mm EPB FireSmart® and 1 x 13mm EPB® Standard
	<b>-F26</b>	60/60/60	LB	51	50	42	2 x 13mm EPB FireSmart®

**Floor Framing**

Timber floor joists shall comply with NZS3604 and spaced at no more than 600mm centres. Solid strutting is required in accordance with NZS 3604.

Alternatively, a proprietary I-joist system may be used subject to specific structural design and approved by the normal building consent process.

Nogs fixed on the flat to receive the ends of flooring material shall be 90mm x 45mm minimum.

**Flooring**

Flooring shall be 20mm thick particle board or 17mm thick structural ply, fixed to the joists as per manufacturer's instructions.

Flooring sheet joints must either be formed over framing or have a polypropylene tongue and groove jointer.

**Suspension System**

Rondo® KEY-LOCK™ steel frame suspension system comprising 2.5mm wire hangers at 1200mm centres supporting top cross rails (part 128) spaced at a maximum of 1200mm centres and furring channels (part 129) at 600mm centres.

OR

Rondo ScrewFix® steel frame suspension system comprising 2.5mm wire hangers at 1200mm centres supporting F38 strong back channels spaced at a maximum of 1200mm centres and F37 furring channels at 600mm centres.

OR

Alternative suspension systems with equivalent performance characteristics and layout may be used.

Suspended Grid ceiling system to be installed as per manufacturer's specification.

**Plasterboard Lining**

**NB:** The installer must look for the Product Identification Code on the face paper to ensure the correct board type is installed. Refer to the Face Paper Product Identification Code table on this page.

One layer of 13mm EPB FireSmart® and One layer of 13mm EPB® Standard fixed at right angles to the furring channels. Offset the joints of the outer layer by 600mm from those of the inner layer.

All sheet butt joints must occur on the furring channel. Sheet joints shall be touch fitted.

**Fixing of Linings**

**Fasteners**

System Number	1 <sup>st</sup> Layer	2 <sup>nd</sup> Layer
		Self-Tapping Drywall Screws
<b>E2SC60-FS26</b>	13mm	13mm
<b>E2SC60-F26</b>	25 x 6g	41 x 6g

**Fastener Centres**

Ceiling sheets shall be fixed at 200mm centres along each furring channel and around the ceiling perimeter. Fix at 200mm centres where butt joints occur.

Place fasteners no closer than 12mm from sheet edges. Place fasteners no closer than 18mm from sheet ends. However this can be reduced to 12mm if sheet ends occur on furring channels. Avoid outer layer screws from hitting inner layer screws.

**Wall/Ceiling Junction**

The internal angle between the ceilings and walls must be protected by Cornice or square stopped corners, taped and filled in accordance with EPB® Plasterboard Installation Guide.

**Joining**

Inner layer: Unstopped.

Outer Layer: All fastener heads stopped and all sheet joints reinforced with paper jointing tape and stopped in accordance with the publication entitled EPB® Plasterboard Installation Guide.

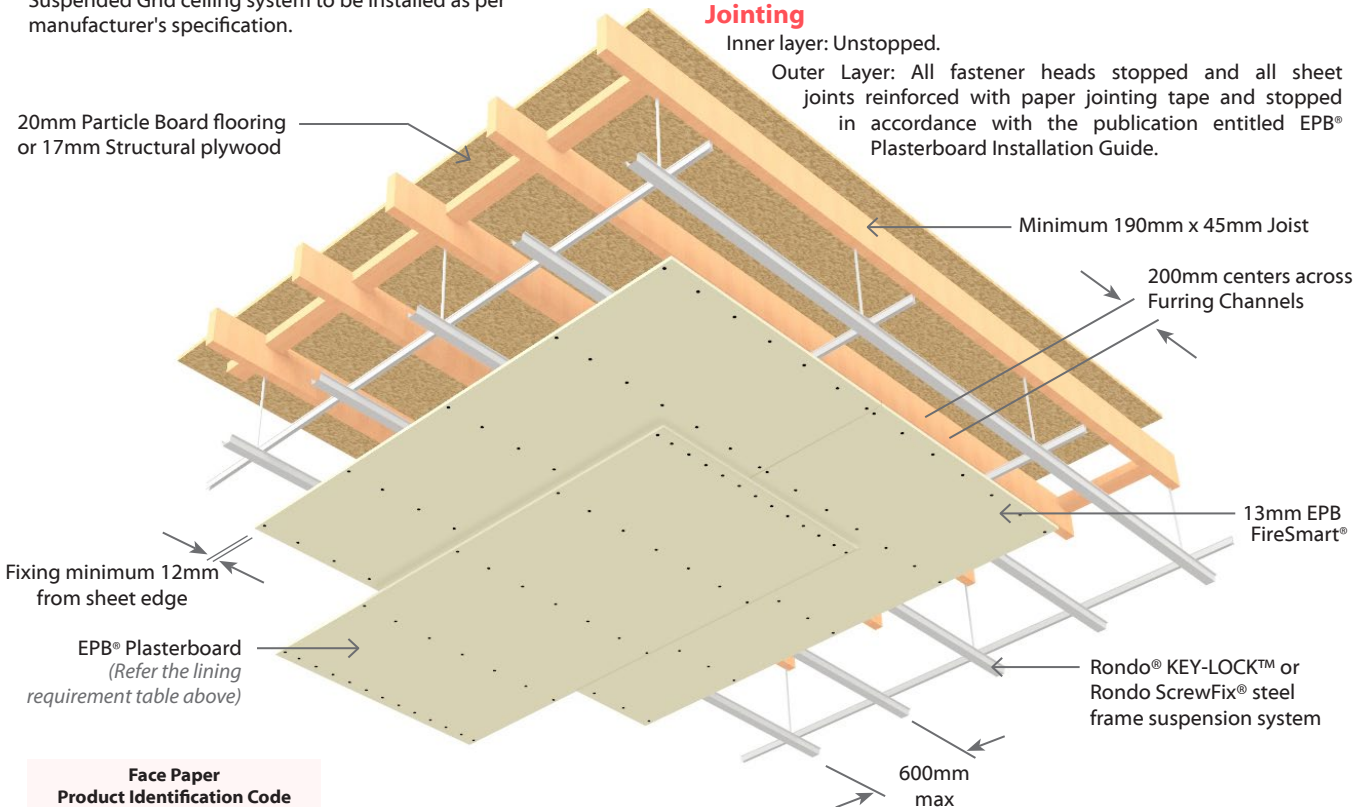

Face Paper Product Identification Code	
13mm EPB® Standard	<b>S13</b>
13mm EPB FireSmart®	<b>F13</b>



**E2SC90**

**Suspended Grid Floor/Ceiling**

**Load Bearing**

**2 Layers: 2 Layers of Plasterboard to underside side of frame**

System Number	Lining Suffix	Fire Rating	Load Bearing Ability	Noise Control			Lining Requirement
				STC	Rw	IIC	
<b>E2SC90</b>	<b>-F32</b>	90/90/90	LB	53	52	43	2 x 16mm EPB FireSmart®

**Floor Framing**

Timber floor joists shall comply with NZS3604 with a minimum depth of 190mm x 45mm and spaced at no more than 600mm centres. Solid strutting is required in accordance with NZS 3604.

Alternatively, a proprietary I-joist system may be used subject to specific structural design and approved by the normal building consent process.

Nogs fixed on the flat to receive the ends of flooring material shall be 90mm x 45mm minimum.

**Flooring**

Flooring shall be 20mm thick particle board or 17mm thick structural ply, fixed to the joists as per manufacturer's instructions.

Flooring sheet joints must either be formed over framing or have a polypropylene tongue and groove jointer.

**Suspension System**

Rondo® KEY-LOCK™ steel frame suspension system comprising 2.5mm wire hangers at 1200mm centres supporting top cross rails (part 128) spaced at a max of 1200mm centres and furring channels (part 129) at 600mm centres.

OR

Rondo ScrewFix® steel frame suspension system comprising 2.5mm wire hangers at 1200mm centres supporting F38 strong back channels spaced at a maximum of 1200mm centres and F37 furring channels at 600mm centres.

OR

Alternative suspension systems with equivalent performance characteristics and layout may be used.

Suspended Grid ceiling system to be installed as per manufacturer's specification.

**Plasterboard Lining**

NB: The installer must look for the Product Identification Code on the face paper to ensure the correct board type is installed. Refer to the Face Paper Product Identification Code table on this page.

Two layers of 16mm EPB FireSmart® fixed at right angles to the furring channels. Offset the joints of the outer layer by 600mm from those of the inner layer.

All sheet butt joints must occur on the furring channel. Sheet joints shall be touch fitted.

**Fixing of Linings**

**Fasteners**

System Number	1 <sup>st</sup> Layer	2 <sup>nd</sup> Layer
		Self-Tapping Drywall Screws
<b>E2SC90-F32</b>	16mm	16mm
	32 x 6g	41 x 6g

**Fastener Centres**

Ceiling sheets shall be fixed at 200mm centres along each furring channel and around the ceiling perimeter. Fix at 150mm centres where butt joints occur.

Place fasteners no closer than 12mm from sheet edges.

Place fasteners no closer than 18mm from sheet ends. However this can be reduced to 12mm if sheet ends occur on furring channels.

Avoid outer layer screws from hitting inner layer screws.

**Wall/Ceiling Junction**

The internal angle between the ceilings and walls must be protected by Cornice or square stopped corners, taped and filled in accordance with EPB® Plasterboard Installation Guide.

**Jointing**

Inner layer: Unstopped.

Outer Layer: All fastener heads stopped and all sheet joints reinforced with paper jointing tape and stopped in accordance with the publication entitled EPB® Plasterboard Installation Guide.

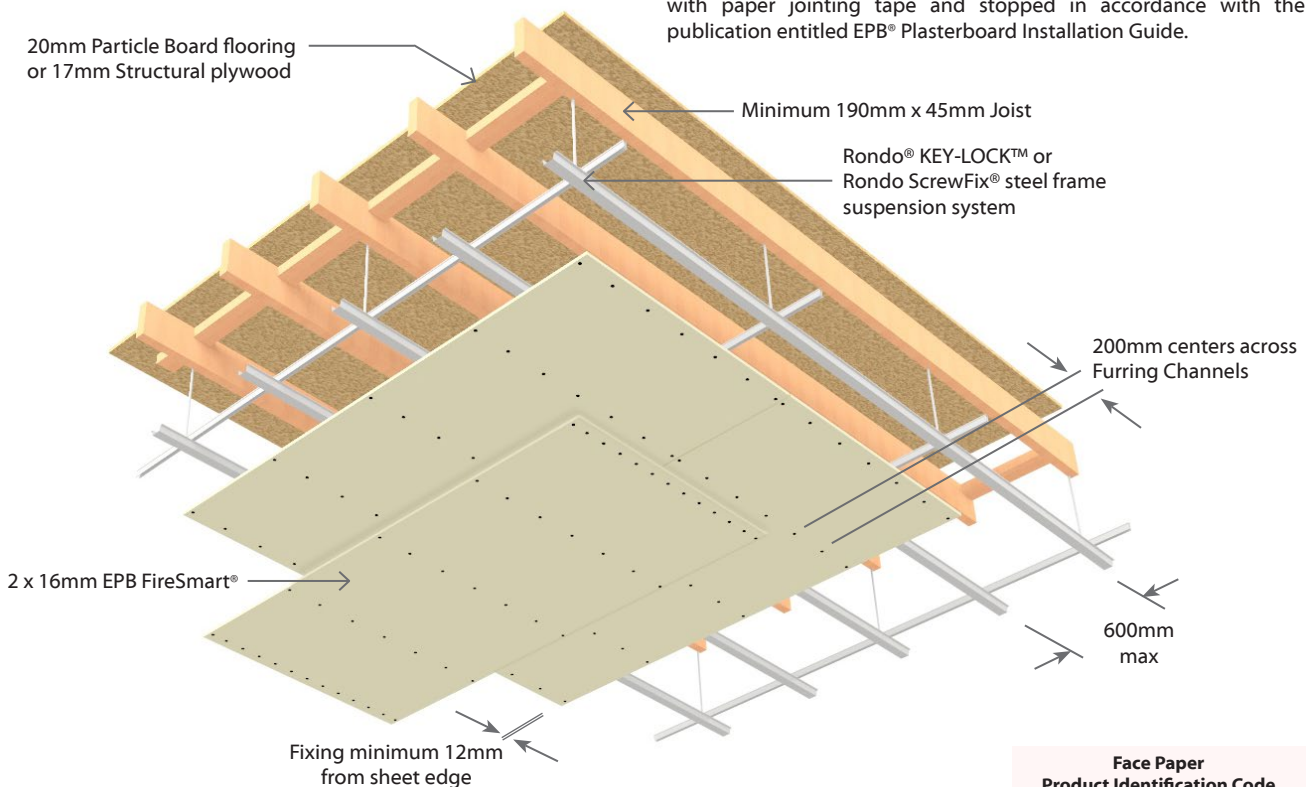

Face Paper Product Identification Code
16mm EPB FireSmart®   <b>F16</b>



2 Layers: 2 Layers of Plasterboard to underside side of frame

System Number	Lining Suffix	Fire Rating	Load Bearing Ability	Noise Control			Lining Requirement
				STC	Rw	IIC	
E2XC90	-F29	90/90/90	LB	48	47	43	1 x 16mm EPB FireSmart® and 1 x 13mm EPB FireSmart®

**Floor Framing**

Timber floor joists shall comply with NZS3604 and spaced at no more than 600mm centres. Solid strutting is required in accordance with NZS 3604.

Alternatively, a proprietary I-joint system may be used subject to specific structural design and approved by the normal building consent process.

Nogs fixed on the flat to receive the ends of flooring material shall be 90mm x 45mm minimum.

**Flooring**

Flooring shall be 20mm thick particle board or 17mm thick structural ply, fixed to the joists as per manufacturer's instructions.

Flooring sheet joints must either be formed over framing or have a polypropylene tongue and groove jointer.

**Minimum Cavity Depth**

The system requires a minimum of 450mm cavity depth between the ceiling linings and the underside of the flooring.

**Suspension System**

Rondo Express® Drywall Grid ceiling system comprising 2.5mm wire hangers or Rondo XD50 wall angles at 1200mm centres maximum, supporting Rondo XD1 main tee spaced at a maximum of 1200mm centres and Rondo XD2-1200 cross tee installed at 600mm centres. Install Rondo XD2-600 cross tees at 1200mm centres, parallel to the main tee.

Rondo Express® Drywall Grid ceiling system to be installed as per manufacturer's specification.

**Plasterboard Lining**

**NB:** The installer must look for the Product Identification Code on the face paper to ensure the correct board type is installed. Refer to the Face Paper Product Identification Code table on this page.

One layer of 16mm EPB FireSmart® and One layer of 13mm EPB FireSmart® fixed at right angles to the furring channels. The inner layer to be fixed parallel to the main tees with taper edges located on main tees.

The outer layer to be fixed parallel to the main tees and offset by 600mm from those of the inner layer in both direction.

All sheet butt joints must occur on the cross tees.

They shall be adhered with a cove or cornice bond adhesive.

Sheet joints shall be touch fitted.

**Fixing the Lining**

**Fasteners**

System Number	1 <sup>st</sup> Layer	2 <sup>nd</sup> Layer
	Self-Tapping Drywall Screws	
E2XC90-F29	16mm	13mm
	32 x 6g	41 x 6g

**Fastening Centres**

Ceiling sheets shall be fixed at 150mm centres around each sheet perimeter and 200mm centres to intermediate framing.

Place fasteners no closer than 12mm from sheet edges.

Place fasteners no closer than 18mm from sheet ends. However this can be reduced to 12mm if sheet ends occur on cross tees.

**Wall/Ceiling Junction**

The internal angle between the ceilings and walls must be protected by Cornice or square stopped corners, taped and filled in accordance with EPB® Plasterboard Installation Guide.

**Jointing**

Inner layer: Unstopped.

Outer Layer: All fastener heads stopped and all sheet joints reinforced with paper jointing tape and stopped in accordance with the publication entitled EPB® Plasterboard Installation Guide.

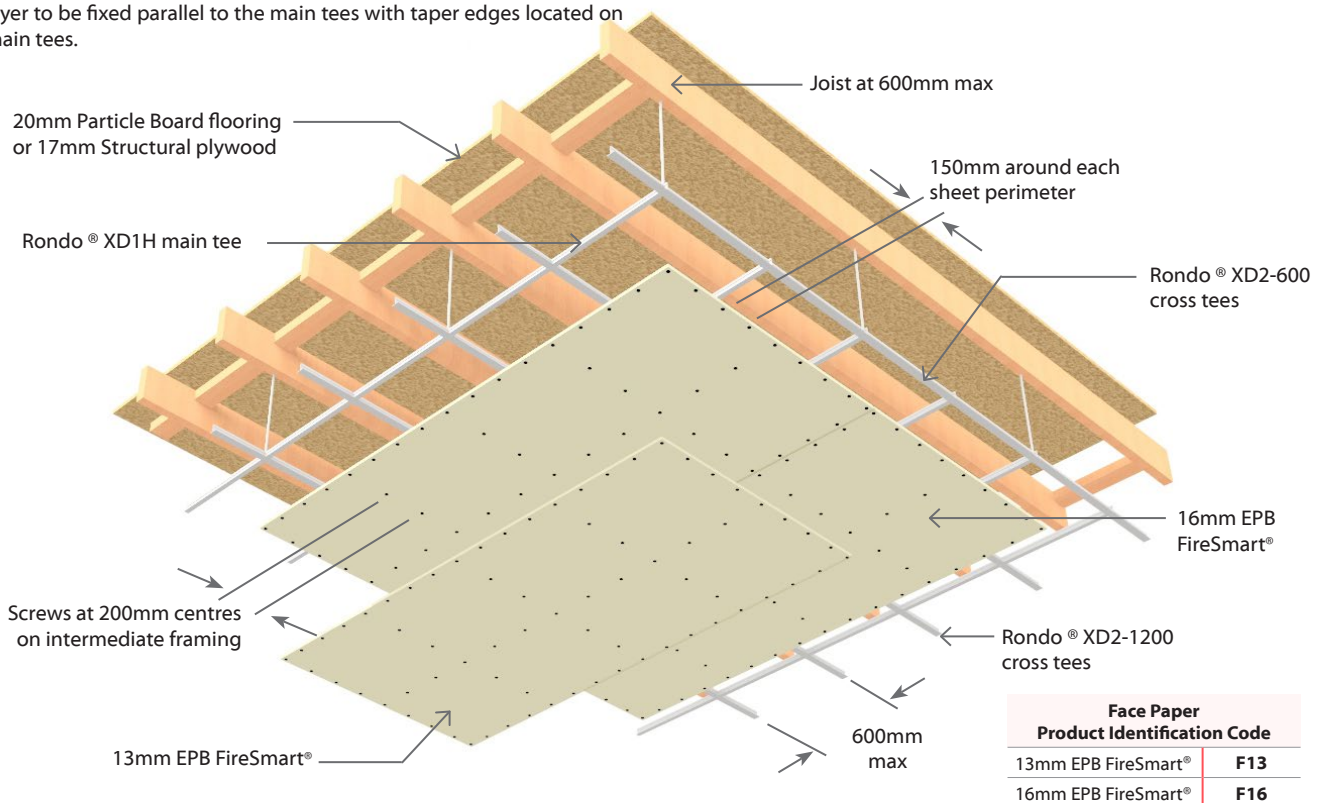



# Fire Rated Universal Ceilings

**E1UC15**

**Universal Ceiling - Timber or Steel Frame**

Load Bearing

One Way FRR

**1 Layer: 1 Layer of Plasterboard to underside side of frame**

System Number	Lining Suffix	Fire Rating	Load Bearing Ability	Noise Control		Lining Requirement
				STC	IIC	
<b>E1UC15</b>	<b>-F13</b>	15/15/15	LB	N/A	N/A	1 x 13mm EPB FireSmart®

**Floor Framing**

Timber or steel roof or floor/ceiling framing designed to meet structural criteria for strength and serviceability under dead and live loads.

The separation between the ceiling lining and any flooring or roofing material shall be 90mm minimum. Linings to be supported by framing members spaced at no more than 600mm centres and with a minimum width of 35mm.

Solid nogs shall be provided at 1200mm centres maximum (to provide solid noggings for the sheet edges) and to the perimeter of the ceiling. For timber construction, the nogs shall be 75mm x 40mm minimum.

**Plasterboard Lining**

**NB:** The installer must look for the Product Identification Code on the face paper to ensure the correct board type is installed. Refer to the Face Paper Product Identification Code table on this page.

One layer of 13mm EPB FireSmart® fixed at right angles directly to the underside of the framing above.

All tapered edged and sheet end butt joints must form on solid framing.

Alternatively the tapered edges can be back blocked using 300mm wide strips of 13mm EPB FireSmart®. Use Cornice adhesive to adhere the back blocking pieces as per the EPB® Installation Guide.

Sheets to be touch fitted.

**Fixing of Linings**

**Fasteners**

System Number	Timber Frame	Steel Frame
	High Thread Drywall Screws	Self-Tapping Drywall Screws
<b>E1UC15-F13</b>	13mm	13mm
	41 x 6g	25 x 6g

**Fastener Centres**

Ceiling sheets shall be screw fixed at 200mm centres around the perimeter of the ceiling, along each framing member and where sheet end butt joints occur.

Place fasteners no closer than 12mm from sheet edges.

Place fasteners no closer than 18mm from sheet ends. However this can be reduced to 12mm if sheet ends occur on furring channels or metal ceiling battens.

**Wall/Ceiling Junction**

The internal angle between the ceilings and walls must be protected by Cornice, adhered with cornice adhesive or square stopped corners taped and filled in accordance with EPB® Plasterboard Installation Guide.

**Jointing**

All fastener heads stopped and all sheet joints reinforced with paper jointing tape and stopped in accordance with the publication entitled EPB® Plasterboard Installation Guide.

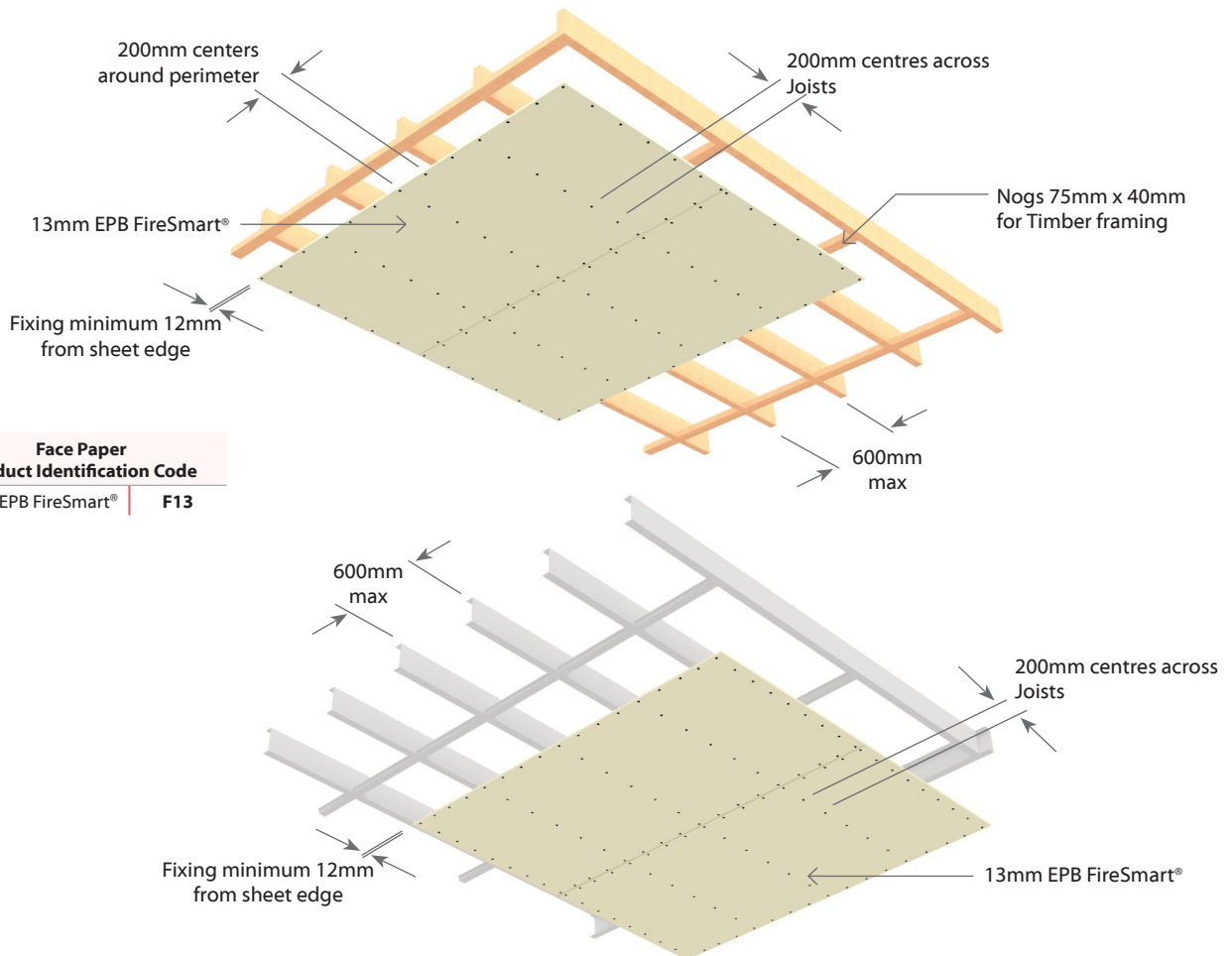

Face Paper Product Identification Code	
13mm EPB FireSmart®	<b>F13</b>



**1 Layer: 1 Layer of Plasterboard to underside side of frame**

System Number	Lining Suffix	Fire Rating	Load Bearing Ability	Noise Control		Lining Requirement	Flooring or Roofing Material
				STC	IIC		
<b>E1UC30</b>	<b>-F16a</b>	30/30/30**	LB	N/A	N/A	1 x 16mm EPB FireSmart®	NO Polymeric foam

\*\* N.B. System E1UC30-F16a achieves the stated fire rating with flooring or roofing materials that do not incorporate polymeric foam

**Floor Framing**

Timber or steel roof or floor/ceiling framing designed to meet structural criteria for strength and serviceability under dead and live loads.

The separation between the ceiling lining and any flooring or roofing material shall be 90mm minimum. Linings to be supported by framing members spaced at no more than 600mm centres and with a minimum width of 35mm.

Solid nogs shall be provided at 1200mm centres maximum (to provide solid nogg for the sheet edges) and to the perimeter of the ceiling. For timber construction, the nogs shall be 75mm x 40mm minimum.

**Plasterboard Lining**

**NB:** The installer must look for the Product Identification Code on the face paper to ensure the correct board type is installed. Refer to the Face Paper Product Identification Code table on this page.

One layer of 16mm EPB FireSmart® fixed at right angles directly to the underside of the framing above.

All tapered edged and sheet end butt joints must form on solid framing.

Alternatively the tapered edges can be back blocked using 300mm wide strips of 16mm EPB FireSmart. Use Cornice adhesive to adhere the back blocking pieces as per the EPB® Plasterboard Installation Guide. Sheets to be touch fitted.

**Fixing of Linings Fasteners**

System Number	Timber Frame	Steel Frame
	High Thread Drywall Screws	Self-Tapping Drywall Screws
<b>E1UC30-F16a</b>	16mm	16mm
	41 x 6g	32 x 6g

**Fastener Centres**

Ceiling sheets shall be screw fixed at 200mm centres around the perimeter of the ceiling, along each framing member and where sheet end butt joints occur.

Place fasteners no closer than 12mm from sheet edges.

Place fasteners no closer than 18mm from sheet ends. However this can be reduced to 12mm if sheet ends occur on furring channels or metal ceiling battens.

**Wall/Ceiling Junction**

The internal angle between the ceilings and walls must be protected by Cornice, adhered with Cornice adhesive or square stopped corners taped and filled in accordance with EPB® Plasterboard Installation Guide.

**Jointing**

All fastener heads stopped and all sheet joints reinforced with paper jointing tape and stopped in accordance with the publication entitled EPB® Plasterboard Installation Guide.

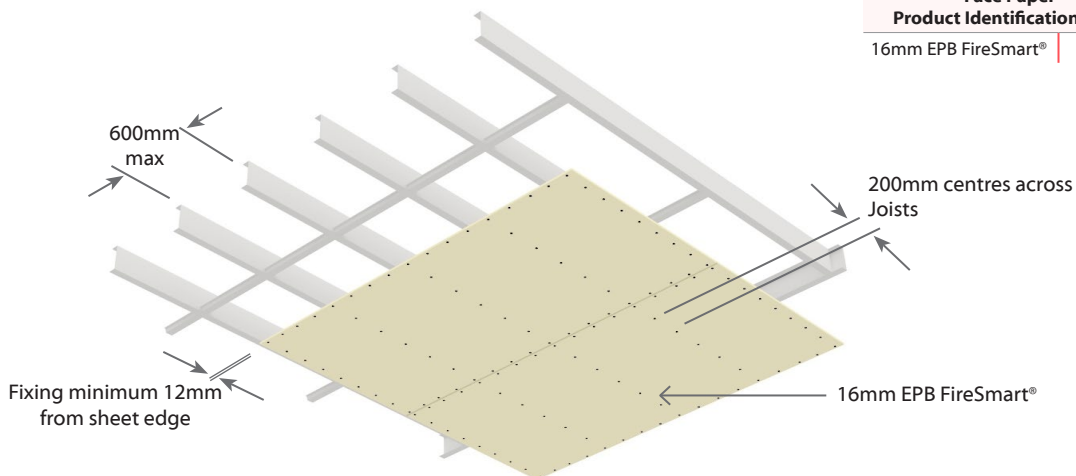
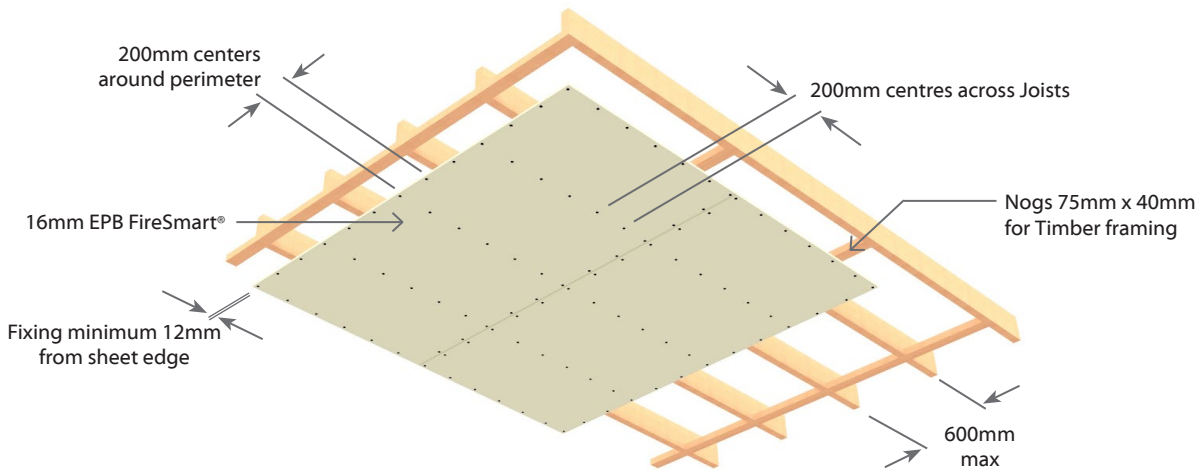

Face Paper Product Identification Code	
16mm EPB FireSmart®	<b>F16</b>



**E2UC60**

**Universal Ceiling - Timber or Steel Frame**

**Load Bearing**

**One Way FRR**

**2 Layers:** 2 Layers of Plasterboard to underside side of frame

System Number	Lining Suffix	Fire Rating	Load Bearing Ability	Noise Control		Lining Requirement	Flooring or Roofing Material
				STC	IIC		
<b>E2UC60</b>	<b>-F26a</b>	60/60/60**	LB	N/A	N/A	2 x 13mm EPB FireSmart®	NO Polymeric foam
	<b>-F29</b>	60/60/60	LB	N/A	N/A	1 x 16mm EPB FireSmart® and 1 x 13mm EPB FireSmart®	Any Material

\*\* N.B. System E2UC60-F26a achieves the stated fire rating with flooring or roofing materials that do not incorporate polymeric foam

**Floor Framing**

Timber or steel roof or floor/ceiling framing designed to meet structural criteria for strength and serviceability under dead and live loads.

The separation between the ceiling lining and any flooring or roofing material shall be 90mm minimum. Linings to be supported by framing members spaced at no more than 600mm centres and with a minimum width of 35mm.

Solid nogs shall be provided at the perimeter of the ceiling.

For timber construction, the nogs shall be 75mm x 40mm minimum.

**Plasterboard Lining**

**NB:** The installer must look for the Product Identification Code on the face paper to ensure the correct board type is installed. Refer to the Face Paper Product Identification Code table on this page.

Two layers of EPB® Plasterboard as per specified system above fixed at right angles directly to the underside of the framing above.

All sheet end butt joints must form on solid framing.

The joints of the second layer should be offset 600mm from those of the first layer.

Sheets to be touch fitted.

**Fixing of Linings**

**Fasteners**

System Number	Timber Frame		Steel Frame	
	1 <sup>st</sup> Layer	2 <sup>nd</sup> Layer	1 <sup>st</sup> Layer	2 <sup>nd</sup> Layer
	High Thread Drywall Screws		Self-Tapping Drywall Screws	
<b>E2UC60-F26a</b>	13mm	13mm	13mm	13mm
	41 x 6g	51 x 7g	25 x 6g	41 x 6g
<b>E2UC60-F29</b>	16mm	13mm	16mm	13mm
	41 x 6g	51 x 7g	32 x 6g	41 x 6g

**Fastener Centres**

For both layers, Ceiling sheets shall be screw fixed at 200mm centres around the perimeter of the ceiling, along each framing member and where sheet end butt joints occur.

Place fasteners no closer than 12mm from sheet edges.

Place fasteners no closer than 18mm from sheet ends. However this can be reduced to 12mm if sheet ends occur on furring channels or metal ceiling battens. Avoid outer layer screws from hitting inner layer screws.

**Wall/Ceiling Junction**

The internal angle between the ceilings and walls must be protected by Cornice, adhered using cornice adhesive or square stopped corners taped and filled in accordance with EPB® Plasterboard Installation Guide.

**Jointing**

Inner Layer: Unstopped.

Outer Layer: All fastener heads stopped and all sheet joints reinforced with paper jointing tape and stopped in accordance with the publication entitled EPB® Plasterboard Installation Guide.

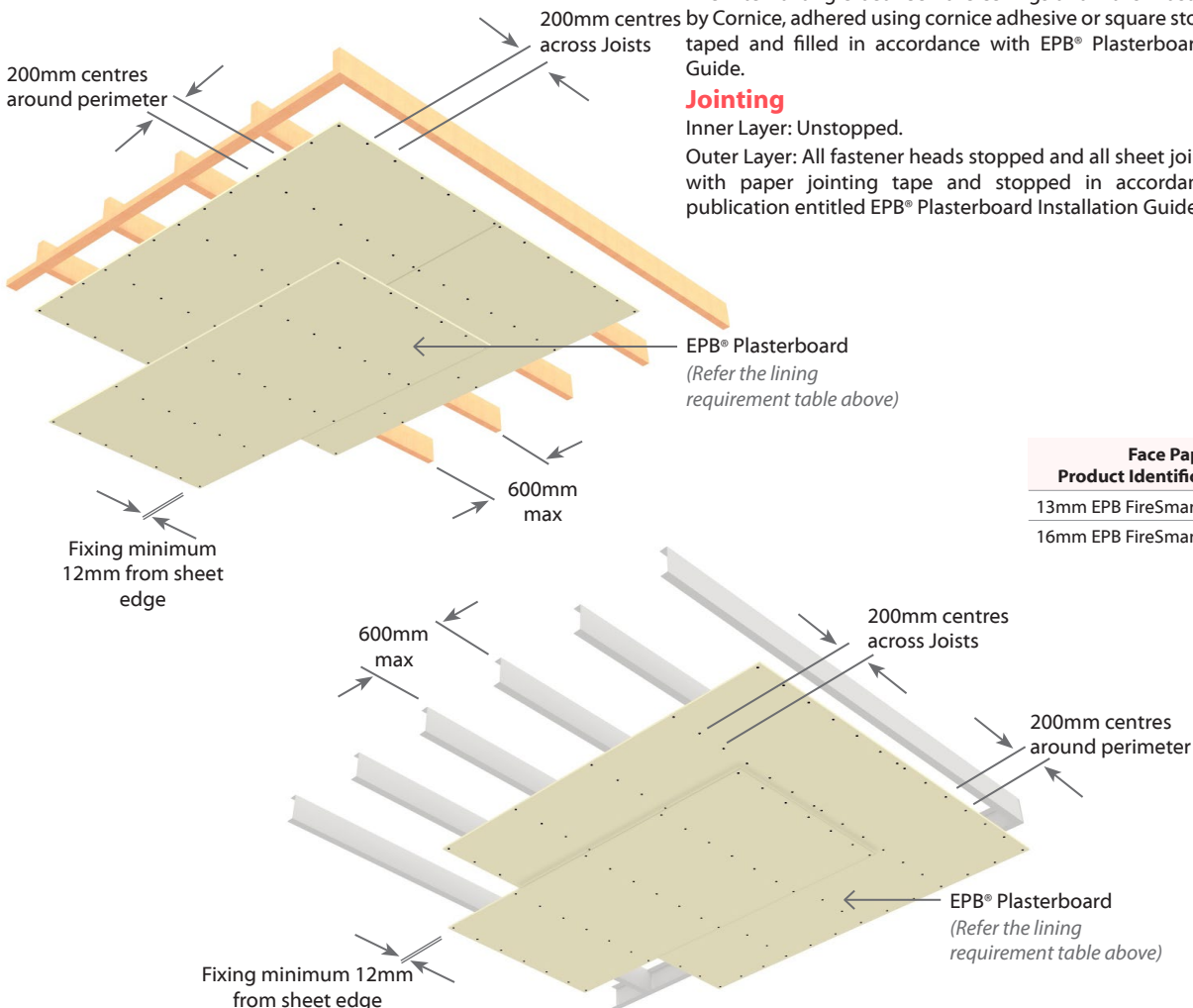

Face Paper Product Identification Code	
13mm EPB FireSmart®	<b>F13</b>
16mm EPB FireSmart®	<b>F16</b>



**E3UC90**

**Universal Ceiling - Timber or Steel Frame**

Load Bearing

One Way FRR

**3 Layers: 3 Layers of Plasterboard to underside side of frame**

System Number	Lining Suffix	Fire Rating	Load Bearing Ability	Noise Control		Lining Requirement	Flooring or Roofing Material
				STC	IIC		
<b>E3UC90</b>	<b>-F39a</b>	90/90/90**	LB	N/A	N/A	3 x 13mm EPB FireSmart®	NO Polymeric foam
	<b>-F42</b>	90/90/90	LB	N/A	N/A	1 x 16mm EPB FireSmart® and 2 x 13mm EPB FireSmart®	Any Material

\*\* N.B. System E3UC90-M39a achieves the stated fire rating with flooring or roofing materials that do not incorporate polymeric foam

**Floor Framing**

Timber or steel roof or floor/ceiling framing designed to meet structural criteria for strength and serviceability under dead and live loads.

The separation between the ceiling lining and any flooring or roofing material shall be 90mm minimum. Linings to be supported by framing members spaced at no more than 600mm centres and with a minimum width of 35mm.

Solid nogs shall be provided at the perimeter of the ceiling.

For timber construction, the nogs shall be 75mm x 40mm minimum.

**Plasterboard Lining**

**NB:** The installer must look for the Product Identification Code on the face paper to ensure the correct board type is installed. Refer to the Face Paper Product Identification Code table on this page.

Three layers of EPB® Plasterboard as per specified system above fixed at right angles directly to the underside of the framing above.

All sheet end butt joints must form on solid framing.

The joints of the each consecutive layer should be offset minimum of 300mm from those of the previous layer.

Sheets to be touch fitted.

**Fixing of Linings**

**Fasteners**

System Number	Timber Frame			Steel Frame		
	1 <sup>st</sup> Layer	2 <sup>nd</sup> Layer	3rd Layer	1 <sup>st</sup> Layer	2 <sup>nd</sup> Layer	3rd Layer
	High Thread Drywall Screws			Self-Tapping Drywall Screws		
<b>E3UC90-F39a</b>	13mm	13mm	13mm	13mm	13mm	13mm
	41 x 6g	51 x 7g	63 x 8g	25 x6g	41 x 6g	51 x 7g
<b>E3UC90-F42</b>	16mm	13mm	13mm	16mm	13mm	13mm
	41 x 6g	51 x 7g	63 x 8g	32 x6g	41 x 6g	63 x 8g

**Fastener Centres**

For all layers, ceiling sheets shall be screw fixed at 150mm centres around ceiling perimeter, and at each sheet end butt joint. Fix at 200mm centres along each framing member.

Fasteners to be placed no closer than 12mm from sheet edge.

Place fasteners no closer than 18mm from sheet ends. However this can be reduced to 12mm if sheet ends occur on furring channels or metal ceiling battens.

Avoid outer layer screws from hitting inner layer screws.

**Wall/Ceiling Junction**

The internal angle between the ceilings and walls must be protected by Cornice, adhered using cornice adhesive or square stopped corners taped and filled in accordance with EPB® Plasterboard Installation Guide.

**Jointing**

Inner Layers: Unstopped.

Outer Layer: All fastener heads stopped and all sheet joints reinforced with paper jointing tape and stopped in accordance with the publication entitled EPB® Plasterboard Installation Guide.

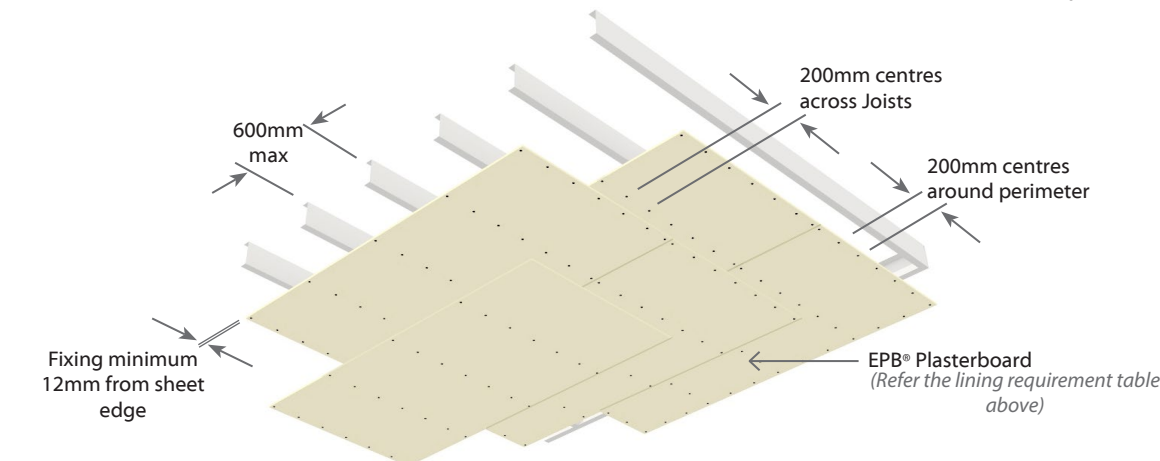
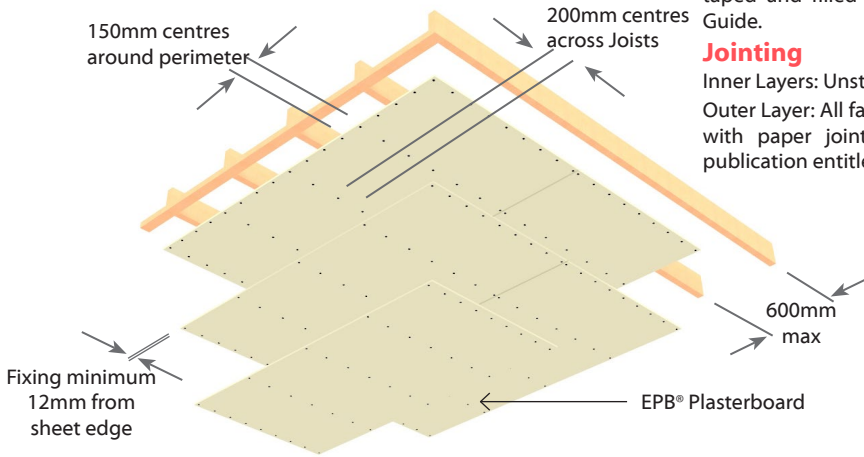

Face Paper	Product Identification Code
13mm EPB FireSmart®	<b>F13</b>
16mm EPB FireSmart®	<b>F16</b>







# Fire Rated Speciality Systems

EPB® Shaft Panels using any selected EPB® Plasterboard Fire or Noise Control System

EPB® Shaft Panel systems outlined in this manual are when construction can only be done from one side. Ideal for lift and service shaft enclosures.

Any conventional steel or timber framing EPB® Plasterboard System within this manual or EPB Noise Control Manual can be referred to in terms of lining and FRR. For installation and fixing details, look at the selected EPB system's technical specification

**Framing Construction**

Construct the framing by friction fitting steel or timber studs into the top and bottom steel channels. Cut the studs minimum 15mm less than the full height between the top and bottom channel to allow an expansion gap. The channels are not continuous.

**Packers**

Place strips of plasterboard packers on each side of the end studs and at the head of the panel. The packer thickness on the head of the panel depends on the floor deflection required.

**Shaft Side Lining**

EPB® Plasterboard as per the specified system to be screw fixed to the framing on the shaft side of the panel. Fixing to bottom channels is optional. Do not fix to top channels.

**Panel Installation Procedure**

**Erecting the panel**

Move and fix the panels into positions by screwing the top channel into to the above structure and the bottom channel to the floor. Allow for the required deflection gap and make sure the plasterboard lining overlaps by 6mm above the head packers.

Construct the next panels in the similar way, move them into position and secure them in place and against the previous panel by screwing through the end stud plasterboard packers.

Once all panels have been installed, and the shaft is enclosed, fill any minor gaps with Flexible Fire rated sealant of the same FRR as required before lining the landing side.

When connecting to structural steel, install the channels before fireproofing spray application.

**Landing Side Lining**

Fix EPB Plasterboard as per the specified system vertically to each stud and hard to the floor. Use full height sheets where possible. Staggered joints are required for systems with more than one layer of plasterboard. The top gaps are to be filled with Flexible Fire rated sealant of the same FRR as required. All sheets shall be formed over framing and sheet end butt joints must be formed over nogs.

For detailed instructions on fixings, refer to the relevant technical page of the chosen EPB® Plasterboard system.

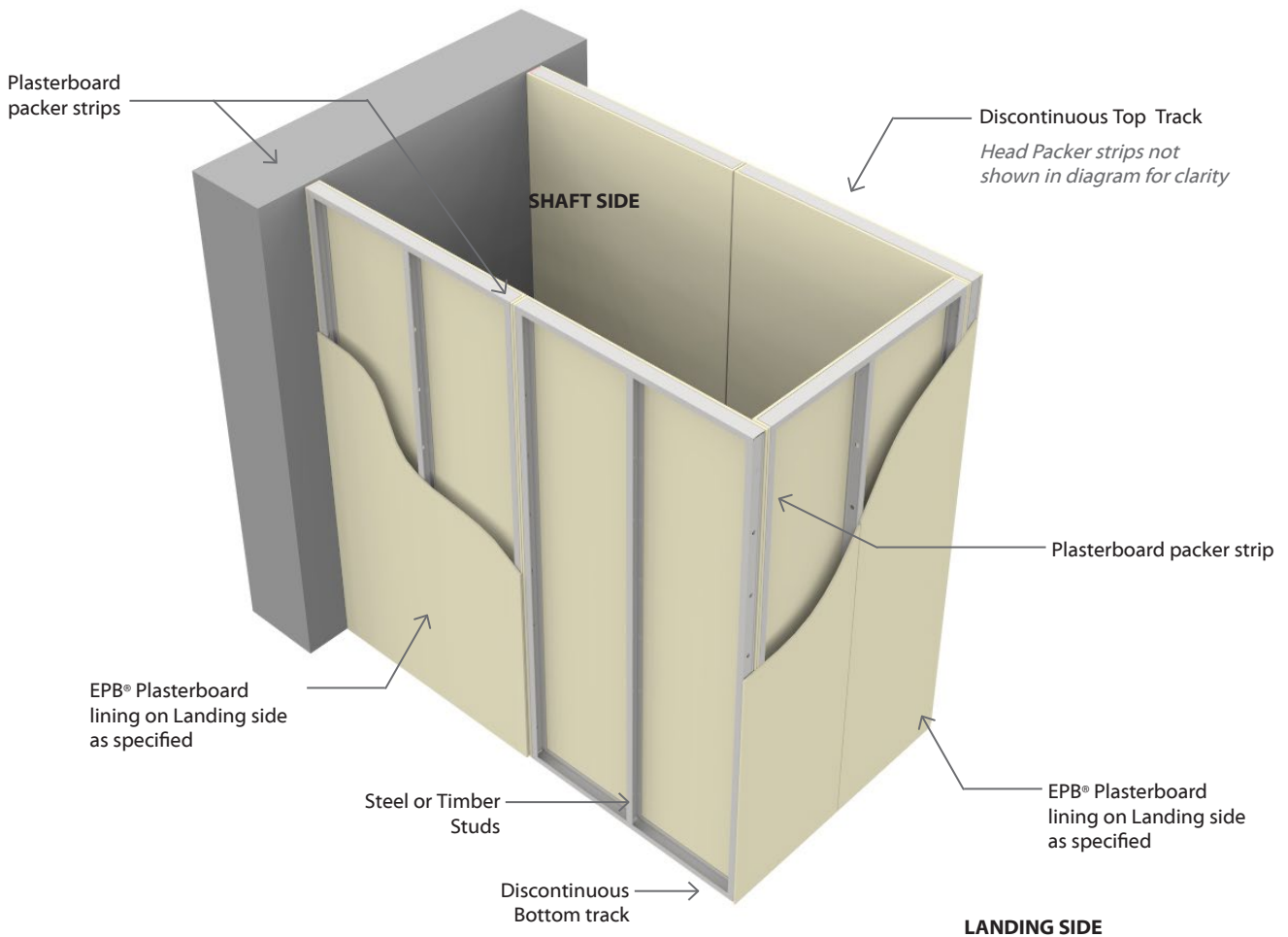

EPB® Shaft Panels using any selected EPB® Plasterboard Fire or Noise Control System

PLAN

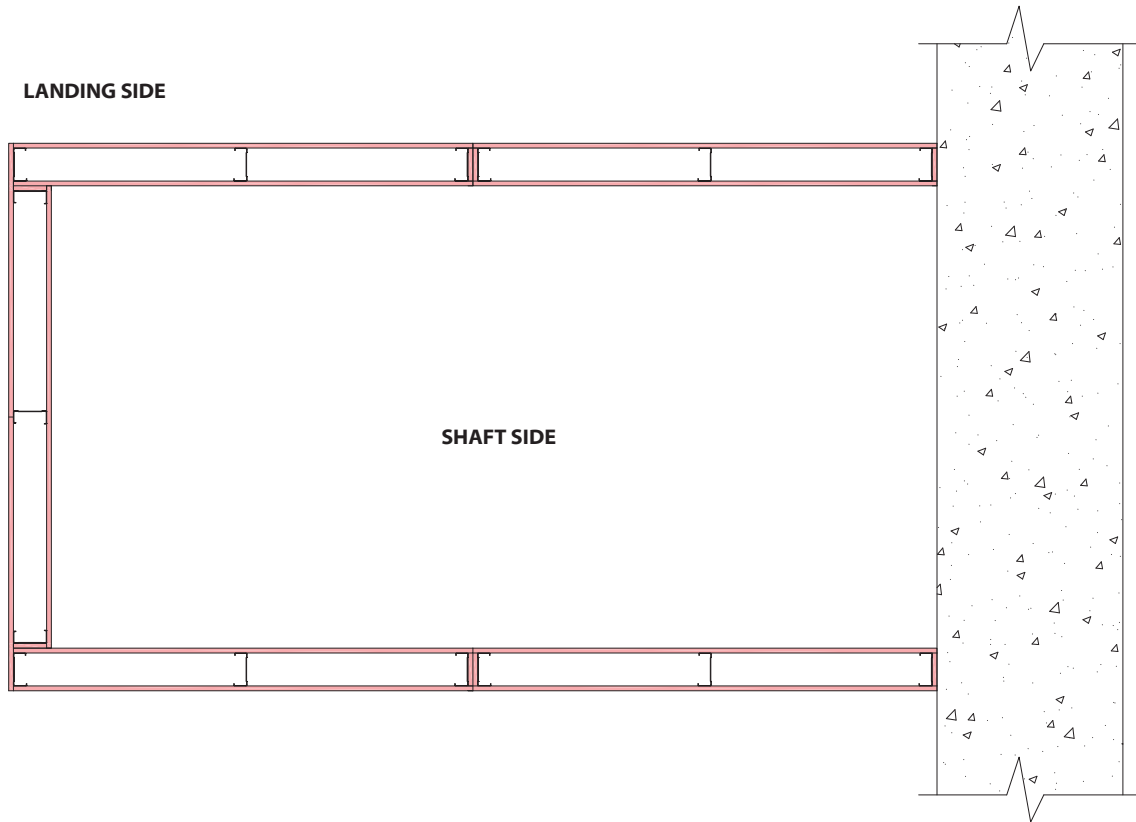

EFS-317

SECTION

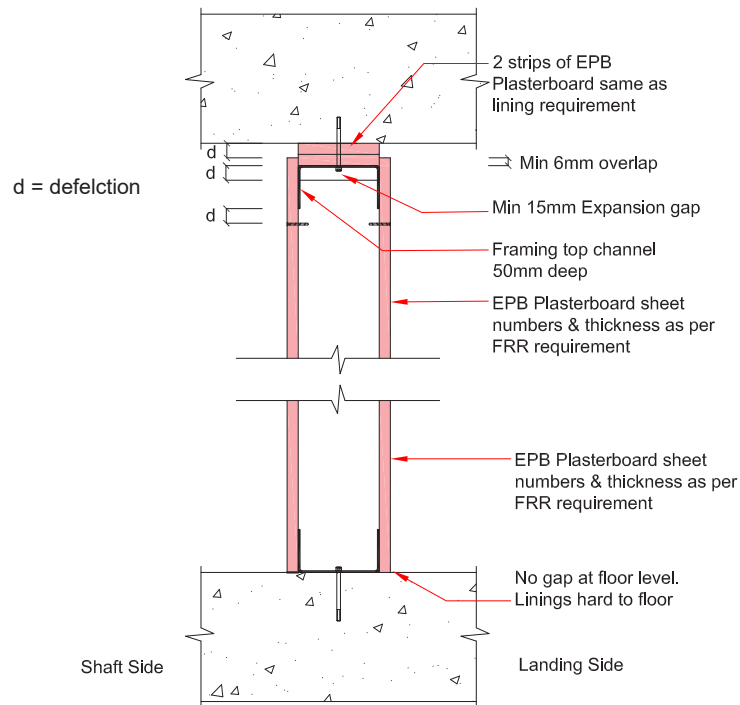

EFS-318



**E1SWS, E2SWS**

**Shaftwall - Fire Rated from Shaft side**

**One Way FRR**

**E1SWE, E2SWE, E3SWE**

**Shaftwall - Fire Rated from Either side**

**Two Way FRR**

**1, 2 or 3** Layers: No. of Layers of Plasterboard to one side of frame (Fire side)

System Number	Lining Suffix	Fire Rating	Fire Rated Side	Noise Control				Landing Side Lining Requirement
				STC				
				64mm stud		102mm stud		
				No fill	Fill	No fill	Fill	
E1SWS60	-F13	-/60/60	Shaft Side	39	45	42	46	1 x 13mm EPB FireSmart®
E2SWS90	-F26	-/90/90		43	49	46	50	2 x 13mm EPB FireSmart®
E2SWS120	-F29	-/120/120		44	50	46	51	1 x 16mm EPB FireSmart® and 1 x 13mm EPB FireSmart®
E1SWE30	-F13	-/30/30	Either Side	39	45	42	46	1 x 13mm EPB FireSmart®
E2SWE60	-F26	-/60/60		43	49	46	50	2 x 13mm EPB FireSmart®
E2SWE90	-F29	-/90/90		44	50	46	51	1 x 16mm EPB FireSmart® and 1 x 13mm EPB FireSmart®
E3SWE120	-F42	-/120/120		46	51	48	52	1 x 16mm EPB FireSmart® and 2 x 13mm EPB FireSmart®

EPB® Shaftwall systems outlined in this manual are when construction can only be done from one side. Ideal for lift and service shaft enclosures. All EPB® Shaftwall systems are non-load bearing.

**Framing**

EPB® Shaftwall systems utilises Rondo® E-Stud, CH-Stud and J-Track. Fix the Rondo® J-Tracks as the top and bottom channels. The vertical framing begins with the E-Stud, followed by CH-Studs and ends with the J-Stud. See construction sequence over page.

When connecting to structural steel, install the framing before fireproofing spray application.

**Wall heights**

Maximum Stud heights				
System Number	Stud Size	BMT	Pressure	
			0.25 kPa	0.35 kPa
			E1SWE30-F13 E1SWS60-F13	64
0.90	3460	3090		
E2SWE60-F26 E2SWS90-F26 E2SWE90-F29 E2SWS120-F29 E3SWE120-F42	64	0.55	3730	2660
		0.90	4380	3890
	102	0.55	4250	3080
		0.90	5510	4190

**Framing & Lining Installation Procedure**

**Top and Bottom Tracks**

Mechanically fix the Rondo® J-Track as the top and bottom channels at 600mm centres max and 100mm max from each end. Position the J-Track with short leg facing towards the landing side of the wall. When connecting to structural steel, install the Rondo® J-Track before fireproofing spray application.

**End Studs**

Cut the Rondo® E-Studs 15mm less than the full height between the top and bottom J-Track to allow an expansion gap. Fix the Rondo® E-Stud at 600mm centres max to the structure. Fix a Rondo® J-Stud on the opposite end of the wall using the same procedure, positioning the short leg of the J-Track towards the landing side and long leg towards the shaft side. When connecting to structural steel, install the Rondo® E-Stud and Rondo® J-Stud before fireproofing spray application.

**EPB Plasterboard Linings-Shaft Side**

Note the product identification code on the face paper to ensure the correct board type is installed. Refer to the Face Paper Product Identification Code table

Two layers of 13mm EPB FireSmart® on the shaft side.

Cut the 13mm EPB FireSmart® lengthwise in half, leaving two 600mm wide panels and place them between the Rondo® E-Stud and Rondo® CH-Stud on the side closest to the shaft. Position the cut lining back to back with tapered edge at each side. Fix the panels hard to the floor leaving a 15mm expansion gap at the top of the frame. Fill this gap and other gaps with Flexible Fire rated sealant of the same FRR as required before lining the landing side. Use full height sheets where possible. Where sheet end butt joints are unavoidable they should be tight fitted and staggered by 300mm.

**CH-Studs**

Cut the Rondo® CH-Studs 15mm less than the full height between the top and bottom J-Track to allow an expansion gap. Friction fit the Rondo® CH-Studs vertically into the J-Track at 600mm centres max with the C profile of the CH-Stud facing towards the landing side and H profile towards the shaft side. Position the stud such that the shaft side panels slip into the H profile of the CH-Stud. This process is repeated further until the final gap is 600mm or less.

**End Lining Panel - Fixing & Fastening**

Cut the final lining panel to such a size that it fits into the already installed J-Stud. To fit the final end panel into the bottom J-Track, cut the flange of the J-Track and bend it down to fit the panel in and then return it back to vertical. Screw fix these panels to the long leg side of the Rondo® J-Stud using 41mm x 6g Self Tapping Drywall screws at 300mm centres. Fill the 15mm gap between the boards and the top J-Track and the gap between the J-Stud and the board with Flexible Fire rated sealant of the same FRR as required before lining the landing side.

**Landing Side Lining**

Note the product identification code on the face paper to ensure the correct board type is installed. Refer to the Face Paper Product Identification Code table

Fix EPB® plasterboard as per specified system vertically to each stud at 300mm centres and hard to the floor. Use full height sheets where possible. Do not fix the sheets to the top and bottom Rondo® J-Tracks. Staggered joints are required for systems with more than one layer of plasterboard. The top gaps are to be filled with Flexible Fire rated sealant of the same FRR as required. All sheets shall be formed over framing and sheet end butt joints must be formed over nogs.



<b>E1SWS, E2SWS</b>	<b>Shaftwall - Fire Rated from Shaft side</b>	<b>One Way FRR</b>
---------------------	---	--------------------

<b>E1SWE, E2SWE, E3SWE</b>	<b>Shaftwall - Fire Rated from Either side</b>	<b>Two Way FRR</b>
----------------------------	--	--------------------

**Fixing of Landing side Linings**

**Fasteners (As per Specified System Above)**

System Number	1 <sup>st</sup> Layer	2 <sup>nd</sup> Layer	3 <sup>rd</sup> Layer
	Self-Tapping Drywall Screws		
<b>E1SWS60-F13</b>	13mm	—	—
<b>E1SWE30-F13</b>	32 x 6g	—	—
<b>E2SWS90-F26</b>	13mm	13mm	—
<b>E2SWE60-F26</b>	32 x 6g	41 x 6g	—
<b>E2SWS120-F29</b>	16mm	13mm	—
<b>E2SWE90-F29</b>	32 x 6g	41 x 6g	—
<b>E3SWE120-F42</b>	16mm	13mm	13mm
	32 x 6g	41 x 6g	63 x 8g

**Fastener centres**

For both layers, sheets shall be screw fixed at 300mm centres along each framing member. Fasteners to be placed no closer than 12mm from sheet edge.

**Jointing**

**Shaft side:** Unstopped

**Landing Side**

Inner Layer: Unstopped.

Single or Outer Layer: All fastener heads stopped and all sheet joints reinforced with paper jointing tape and stopped in accordance with the publication entitled EPB® Plasterboard Installation Guide.

**Shaftwall Framing Components**

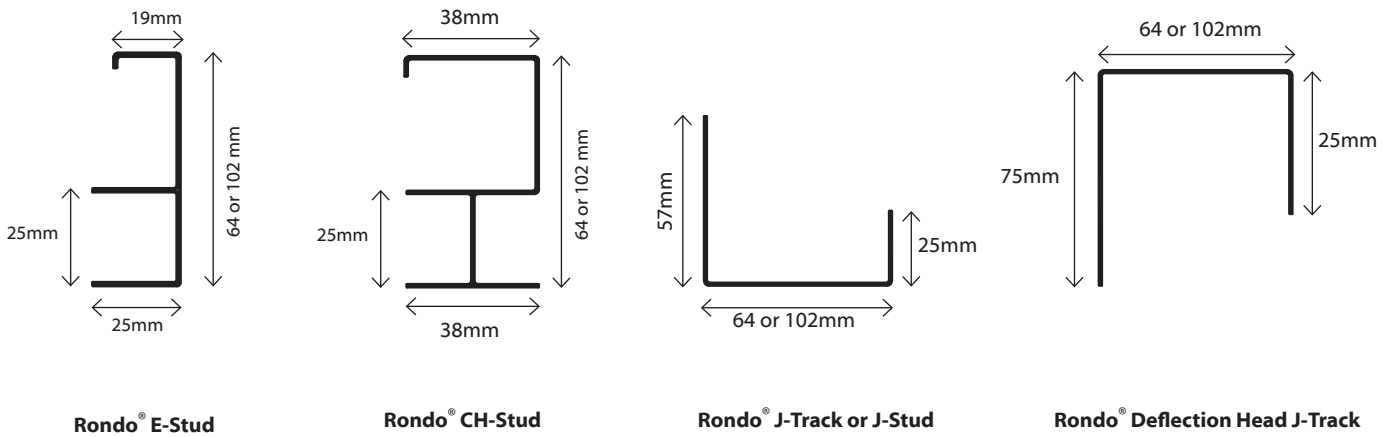

**Construction Sequence**

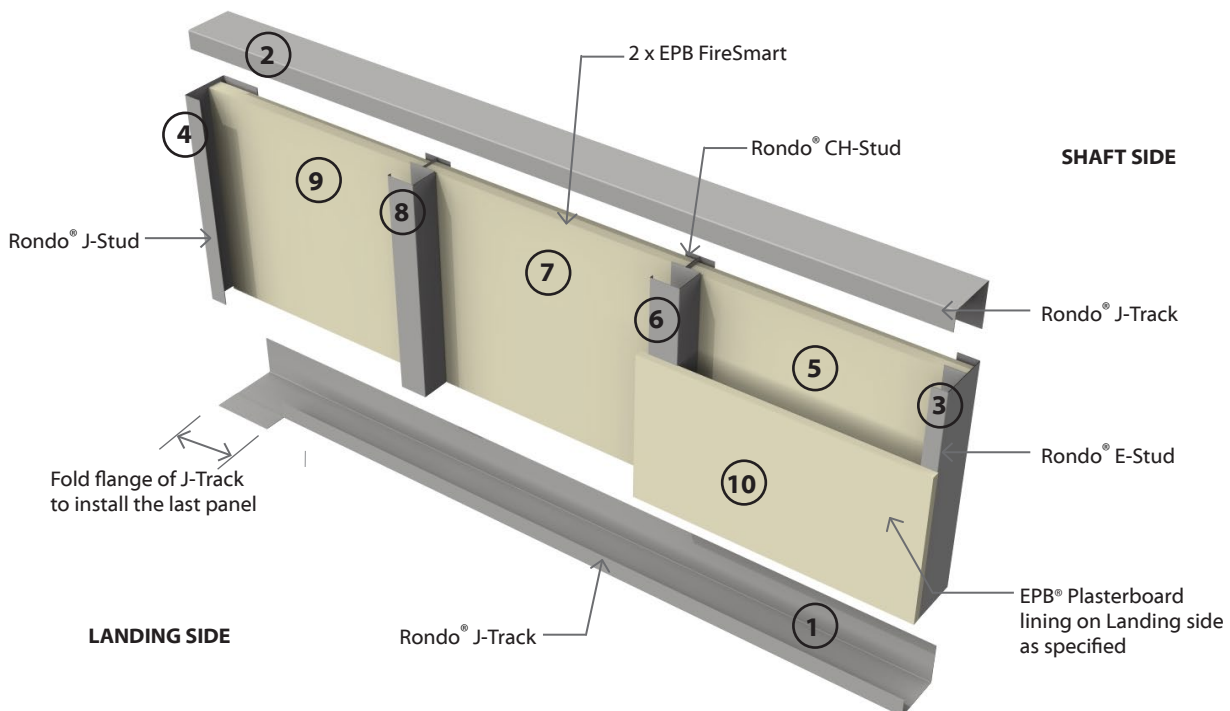

**E1CBT, E2CBT, E3CBT** Steel Column & Beam - Timber Strapped One Way FRR

**1, 2 or 3** Layers: Number of Layers of Plasterboard to one side of frame (Fire side)

System Number	Lining Suffix	Fire Rating	Load Bearing Ability	Noise Control		Lining Requirement
				STC	Rw	
<b>E1CBT15</b>	<b>-S13</b>	15/-/-	LB	N/A	N/A	1 x 13mm EPB® Standard
<b>E1CBT30</b>	<b>-F16</b>	30/-/-	LB	N/A	N/A	1 x 16mm EPB FireSmart®
<b>E2CBT30</b>	<b>-F20</b>	30/-/-	LB	N/A	N/A	2 x 10mm EPB FireSmart®
<b>E2CBT60</b>	<b>-F26</b>	60/-/-	LB	N/A	N/A	2 x 13mm EPB FireSmart®
<b>E2CBT90</b>	<b>-F32</b>	90/-/-	LB	N/A	N/A	2 x 16mm EPB FireSmart®
<b>E3CBT120</b>	<b>-F45</b>	120/-/-	LB	N/A	N/A	1 x 13mm EPB FireSmart® and 2 x 16mm EPB FireSmart®

**Scope**

The system options provided in the table above are a quick reference solution for fire protection of structural steel columns and beams. Specific Fire engineering designs are required for specific column and beam sizes and loading conditions.

**Strapping**

The Columns or Beams are to be strapped with a nominal 50mm x 50mm timber. The linings must be supported by framing members spaced at 600mm centres maximum. No air gap is required as long as support is provided to the protective linings at 600mm centres max on each side of the structural member.

**Plasterboard Lining (Fire Side)**

One, two or three layers of EPB® Plasterboard lining as per specified system above. All joints /edges for the first, second and third layers must be formed over the framing. The joints between subsequent layers must be offset by at least 300mm.

**Fixing of Linings**

**Fasteners (As per Specified System Above)**

System Number	Lining Suffix	Single Layer	2 <sup>nd</sup> Layer	3 <sup>rd</sup> Layer
		High Thread Drywall Screws	Self-Tapping	Self-Tapping
<b>E1CBT15-S13</b>	<b>S13</b>	13mm	—	—
		41 x 6g	—	—
<b>E1CBT30-F16</b>	<b>F16</b>	16mm	—	—
		41 x 6g	—	—
<b>E2CBT30-F20</b>	<b>F20</b>	10mm	10mm	—
		32 x 6g	41 x 6g	—
<b>E2CBT60-M26</b>	<b>F26</b>	13mm	13mm	—
		41 x 6g	51 x 7g	—
<b>E2CBT90-F32</b>	<b>F32</b>	16mm	16mm	—
		41 x 6g	57 x 7g	—
<b>E3CBT120-MF45</b>	<b>F45</b>	13mm	16mm	16mm
		41 x 6g	51 x 7g	63 x 8g

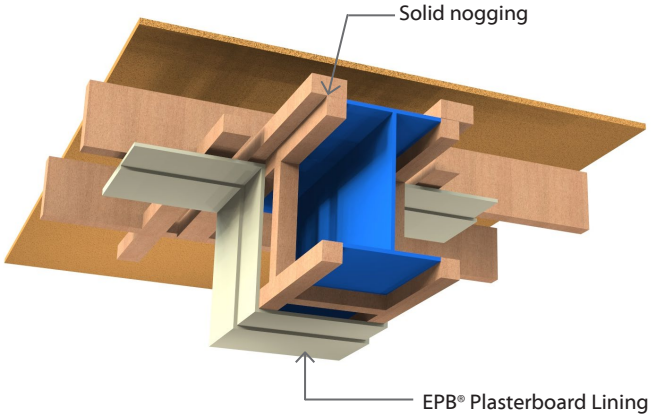

**Fastener Centres**

Fix each layer at 300mm centres maximum to framing. Place fasteners minimum 12mm from the sheet edge.

**Corner Protection**

If required, external corners to be reinforced with external corner beads.

**Jointing**

Inner Layer: Unstopped  
Outer Layer: All fastener heads stopped and all sheet joints reinforced with paper jointing tape and stopped. All in accordance with EPB® Plasterboard Installation Guide.

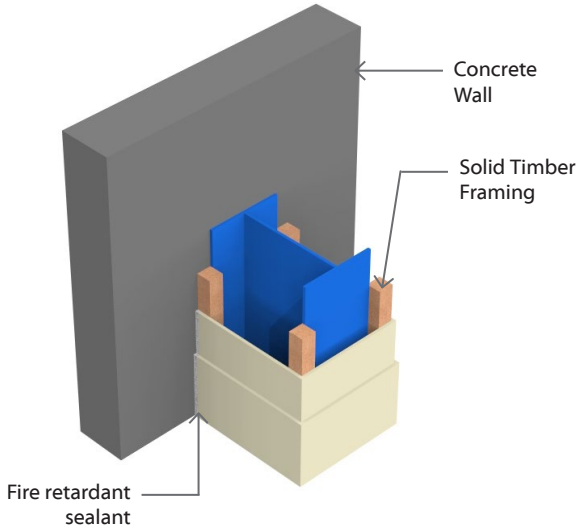
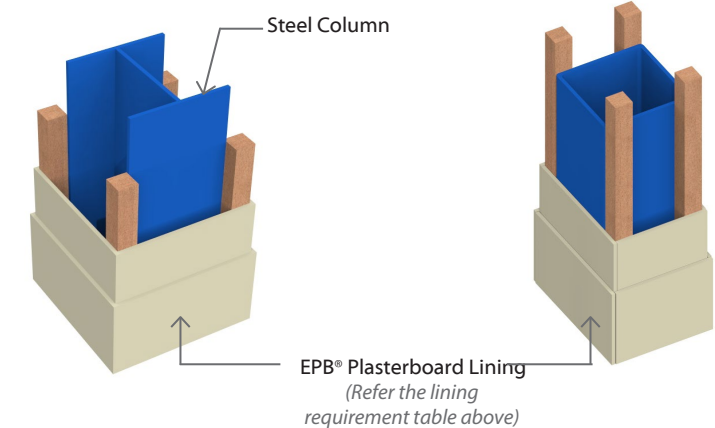

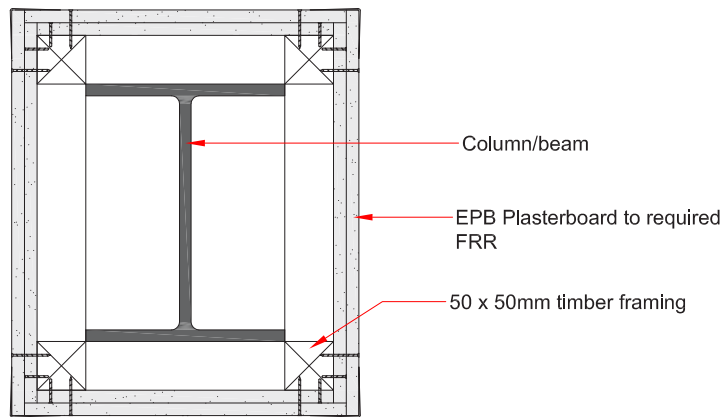

EFS-314

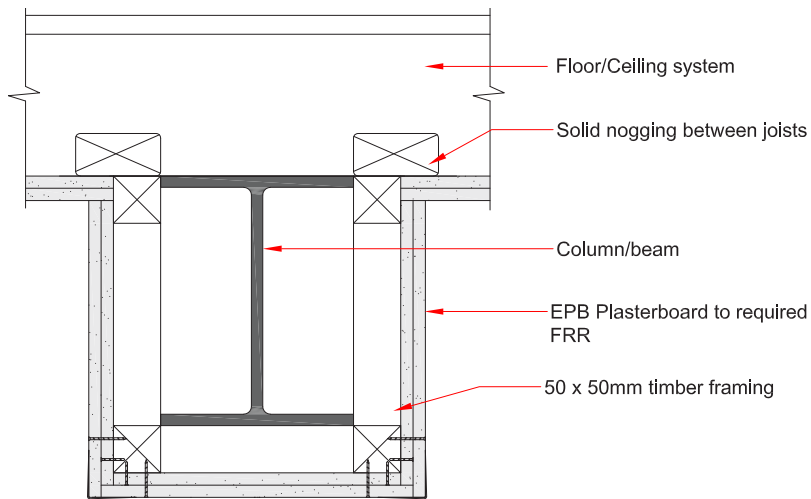

EFS-315

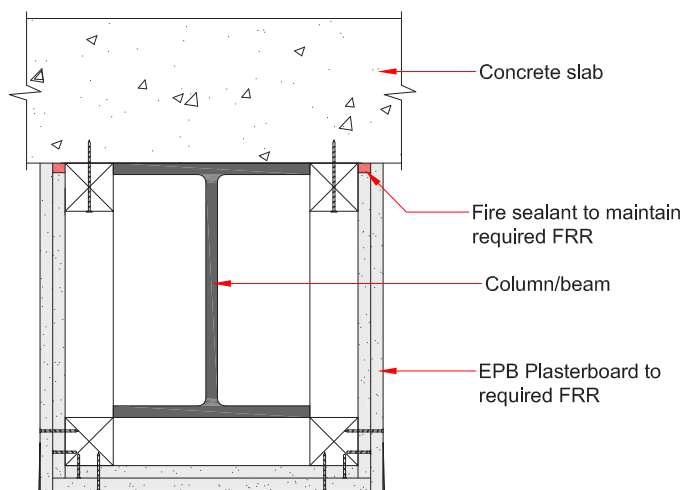

EFS-316



1, 2 or 3 Layers: Number of Layers of Plasterboard to one side of frame (Fire side)

System Number	Lining Suffix	Fire Rating	Load Bearing Ability	Noise Control		Lining Requirement
				STC	Rw	
E1CBS15	-S13	15/-/-	LB	N/A	N/A	1 x 13mm EPB® Standard
E1CBS30	-F16	30/-/-	LB	N/A	N/A	1 x 16mm EPB FireSmart®
E2CBS30	-F20	30/-/-	LB	N/A	N/A	2 x 10mm EPB FireSmart®
E2CBS60	-F26	60/-/-	LB	N/A	N/A	2 x 13mm EPB FireSmart®
E2CBS90	-F32	90/-/-	LB	N/A	N/A	2 x 16mm EPB FireSmart®
E3CBS120	-F45	120/-/-	LB	N/A	N/A	1 x 13mm EPB FireSmart® and 2 x 16mm EPB FireSmart®

**Scope**

The system options provided in the table above are a quick reference solution for fire protection of structural steel columns and beams. Specific Fire engineering designs are required for specific column and beam sizes and loading conditions.

**Steel Clip and Channel**

Attach the Rondo® Beam or Encasement Clip to column or beams at 600mm centres max. Then insert the Rondo® Furring Channel Track (Part 140) into the clips.

Framing members spaced at 600mm centres max to support the linings.

For columns or beams that are exposed on 3 sides use the Rondo® Perimeter Angle (Part NZ18) to allow for the fixing of the plasterboard. The perimeter angle is to be fixed to the wall or underside of floor at maximum 600mm centres with first fixing no more than 100mm from the ends.

**Plasterboard Lining (Fire Side)**

One, two or three layers of EPB® Plasterboard lining as per specified system above. All joints /edges for the first, second and third layers must be formed over the framing. The joints between subsequent layers must be offset by at least 300mm.

**Fixing of Linings**

**Fasteners**

System Number	Lining Suffix	Single Layer	2 <sup>nd</sup> Layer	3 <sup>rd</sup> Layer
		Self-Tapping Drywall Screws		
E1CBS15-S13	S13	13mm		—
		25 x 6g		
E1CBS30-F16	F16	16mm		—
		32 x 6g		
E2CBS30-F20	F20	10mm	10mm	—
		25 x 6g	32 x 6g	
E2CBS60-F26	M26	13mm	13mm	—
		25 x 6g	41 x 6g	
E2CBS90-F32	F32	16mm	16mm	—
		32 x 6g	51 x 7g	
E3CBS120-F45	MF45	13mm	16mm	16mm
		25 x 6g	41 x 6g	63 x 8g

**Fastener Centres**

Fix each layer at 300mm centres maximum to framing. Place fasteners minimum 12mm from the sheet edge.

**Corner Protection**

If required, external corners to be reinforced with external corner beads.

**Jointing**

Inner Layers: Unstopped

Outer Layer: All fastener heads stopped and all sheet joints reinforced with paper jointing tape and stopped. All in accordance with EPB® Plasterboard Installation Guide.

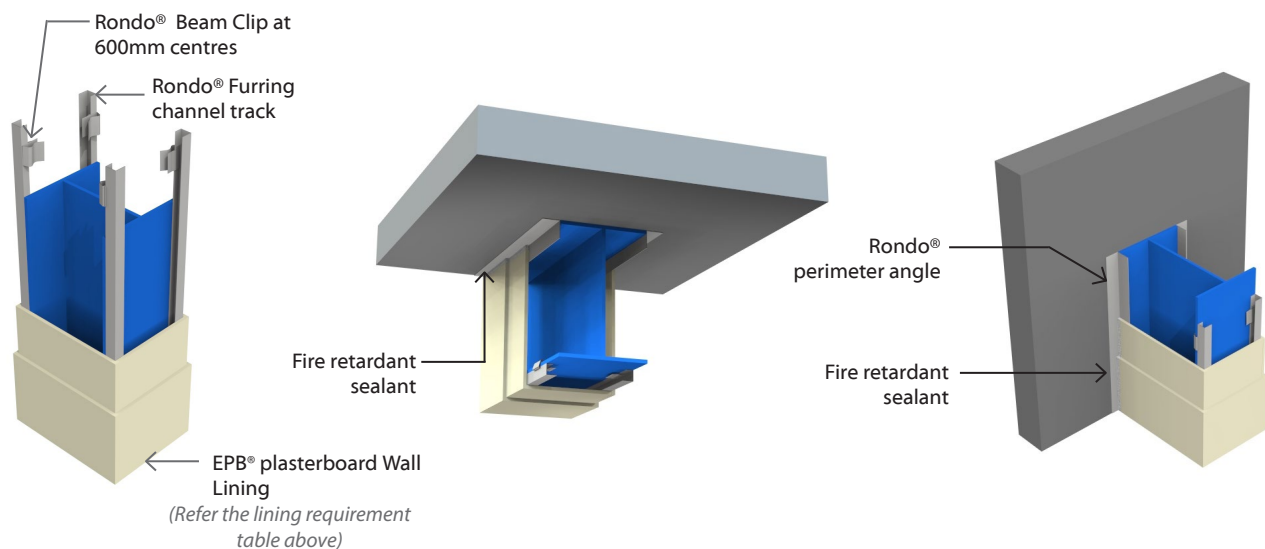

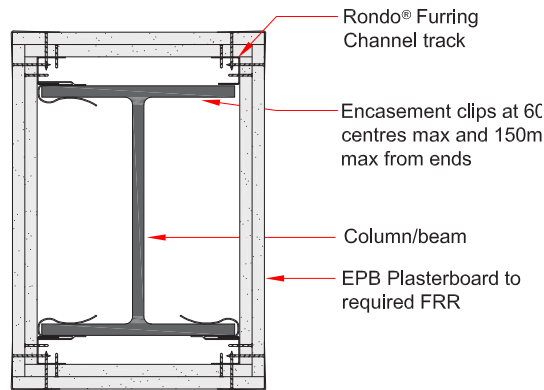

EFS-311

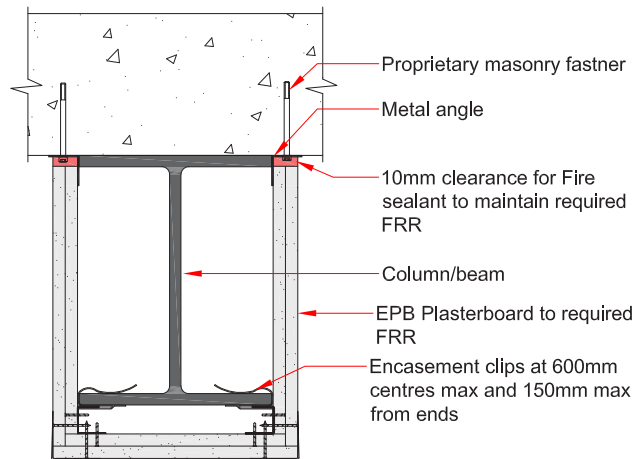

EFS-312

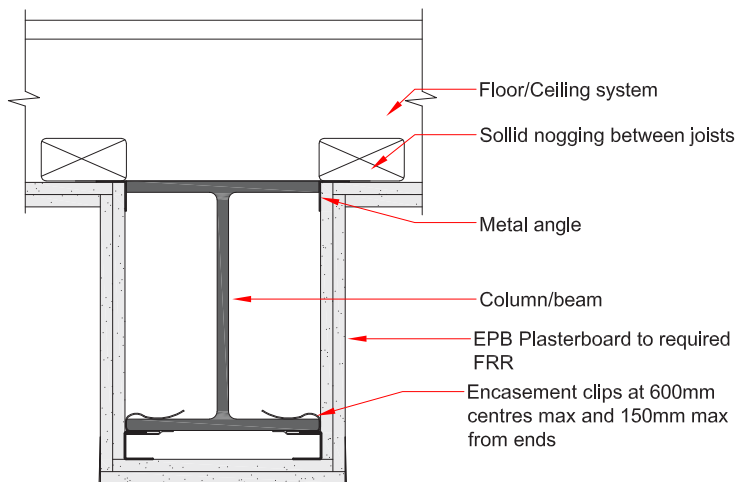

EFS-313





# Construction Details

Control Joints

EFS-057

Steel Frame FRR Wall

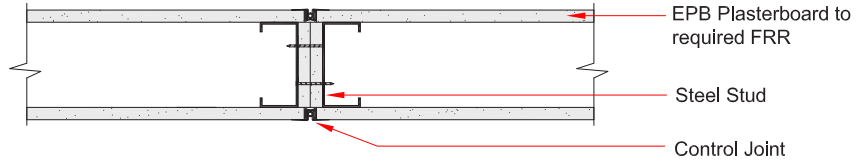

EFS-005

Timber Frame FRR Wall

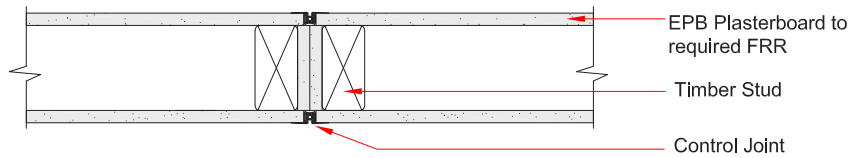

EFS-006

FRR Floor Ceiling

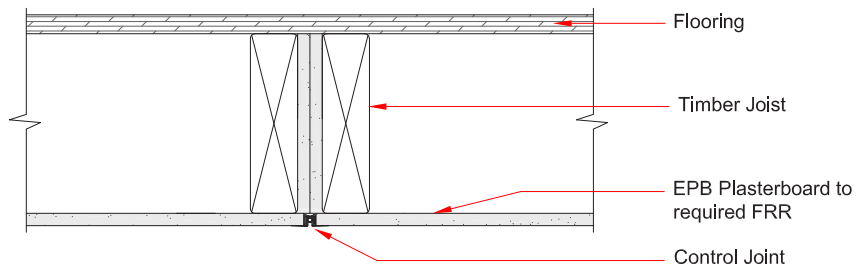

EFS-007

FRR Floor Ceiling

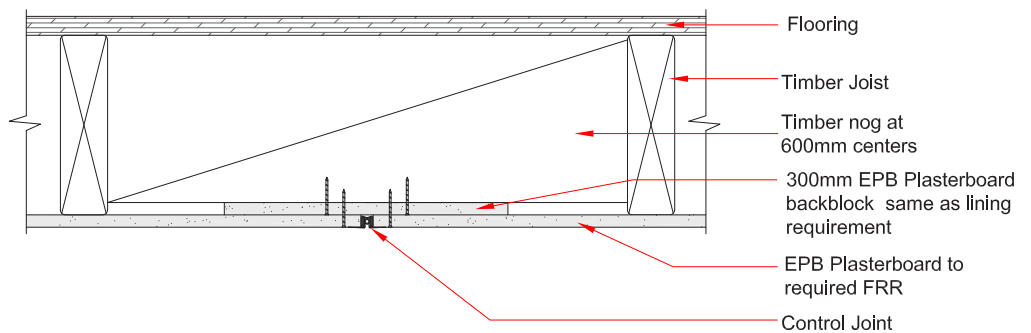

T Junctions & Corner Junction Two Way FRR Systems

EFS-001

Single Timber Frame Wall to Single Timber Frame Wall

For Systems where the difference in FRR between Wall 1 & 2 is 30 minutes or less

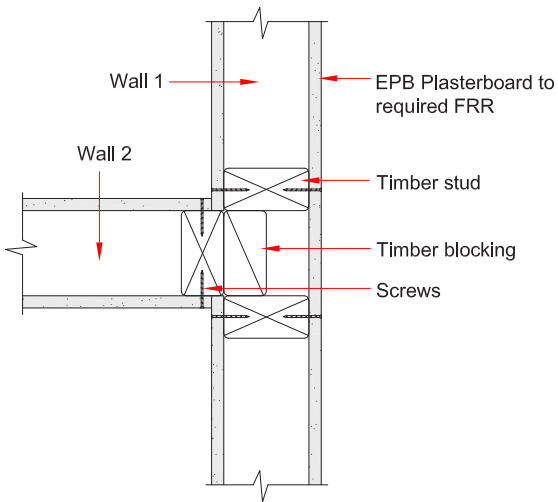

EFS-002

Single Timber Frame Wall to Single Timber Frame Wall

For Systems where the difference in FRR between Wall 1 & 2 is higher than 30 minutes, the lining of wall with higher FRR is continuous. (Wall 1 in this example)

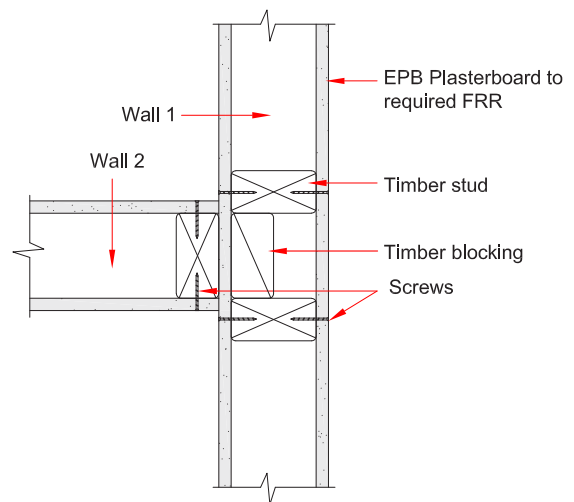

EFS-003

Single Timber Frame Wall to Single Timber Frame Wall - Corner Junction

For Systems where FRR of Wall 1 & 2 are equal

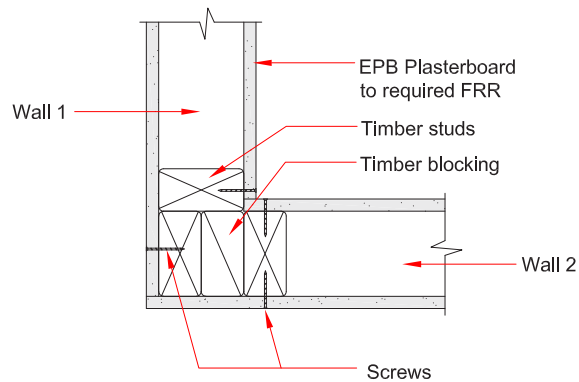

T Junctions & Corner Junction Two Way FRR Systems

EFS-053	Single Steel Frame Wall to Single Steel Frame Wall	EFS-051	Single Steel Frame Wall to Single Steel Frame Wall
---------	--	---------	--

For Systems where FRR of Wall 1 & 2 are equal

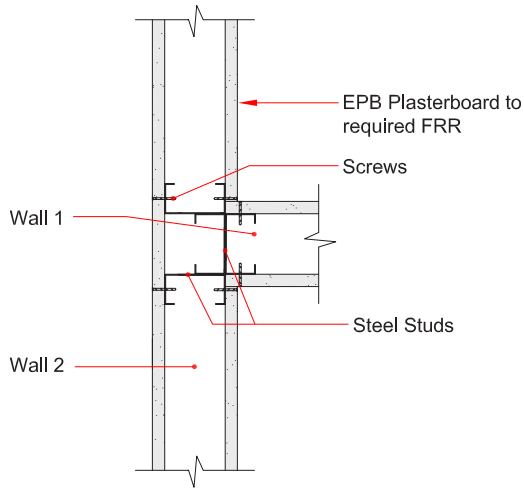

For Systems with Wall 1 & 2 of different FRR, the lining of wall with higher FRR is continuous (Wall 2 in this example)

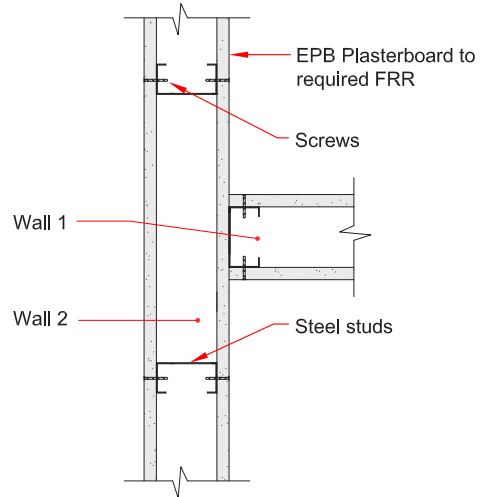

EFS-054	Single Steel Frame Wall to Single Steel Frame Wall - Corner Junction
---------	--

For Systems where FRR of Wall 1 & 2 are equal

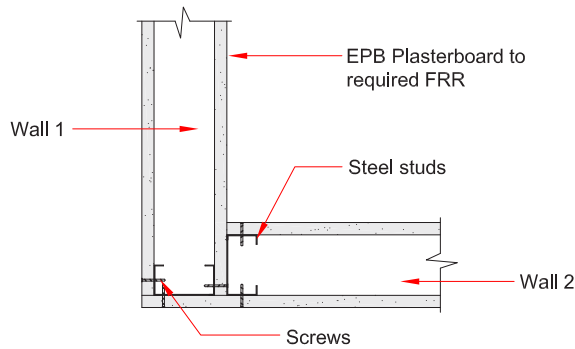

Wall & Floor/Ceiling Junctions

EF5-208

Junction with FRR of Wall being continuous

- If FRR of the wall is greater than the Floor/ceiling by 30 minutes or less
- If Both have the same FRR
- If FRR of the wall is 60 minutes or less
- FRR of the wall is greater than 60 minutes and the FRR of floor/ceiling is 60 minutes less than the wall

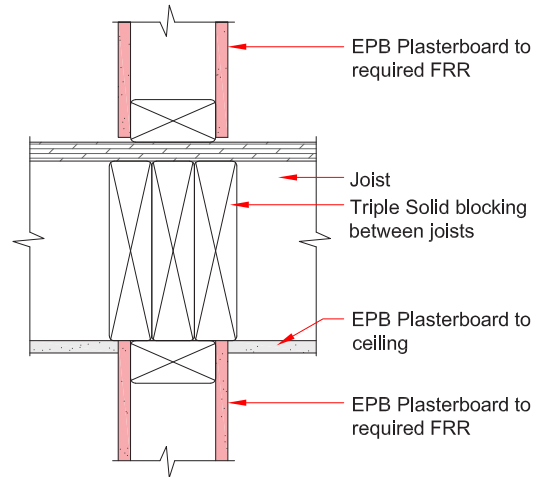
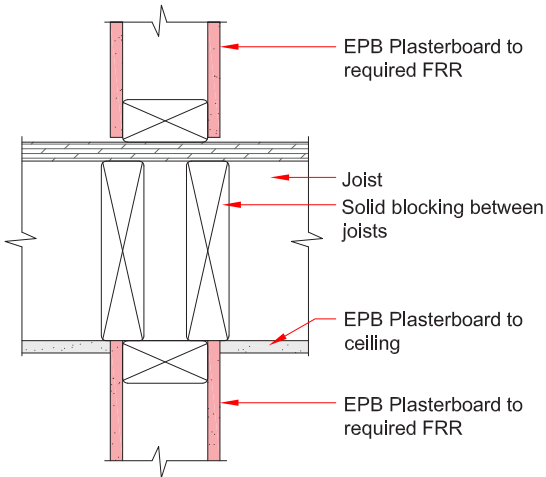

EF5-206

Junction with no Ceiling Lining

- In absence of Ceiling lining, timber double blocking between wall top plate & underside of flooring is required to fill the void.
- Plasterboard must be carried up to the underside of flooring

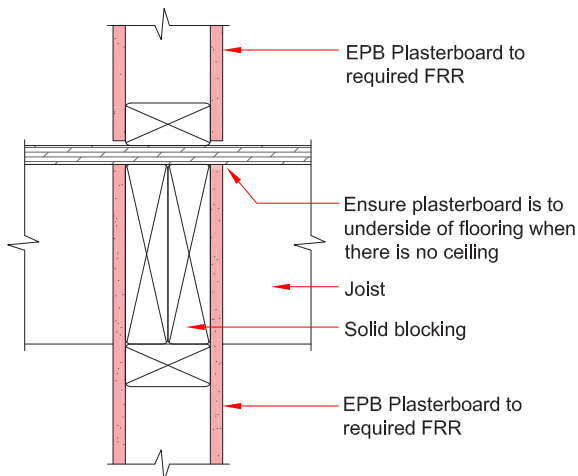

EF5-209

Fire Rated wall and Fire Rated Ceiling Junction

- Load or Non-load bearing Wall
- In case of load bearing wall and it is within the same fire cell, then it should be made a Universal wall in order to maintain structural stability.

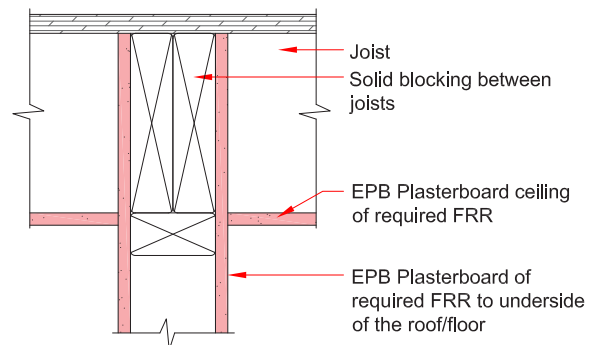

Wall & Floor/Ceiling Junctions

EFB-204

Junction with FRR of Floor/Ceiling being continuous

- FRR of floor/ceiling is higher than the wall
- Difference in FRR is 30 minutes or less
- Non-load bearing wall
- FRR of floor/ceiling is higher than the wall
- Difference in FRR is greater than 30 minutes
- Non-load bearing wall

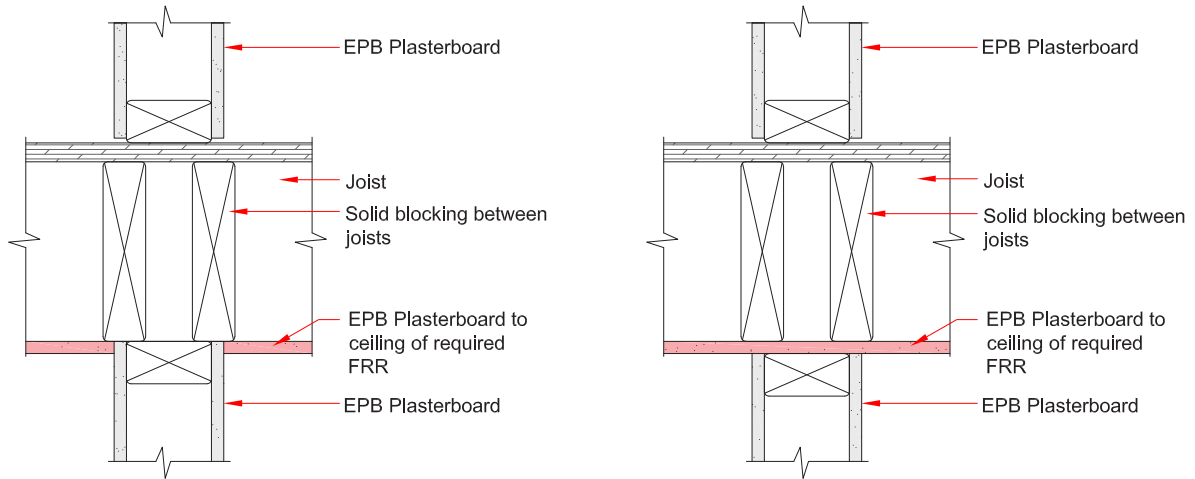

EFB-205

Junction with FRR of Wall & Floor/Ceiling being same

- FRR of floor/ceiling & the wall are the same
- Load or Non-load bearing Wall
- In case of load bearing wall and it not being a fire cell, then it should be made a Universal wall in order to maintain structural stability.

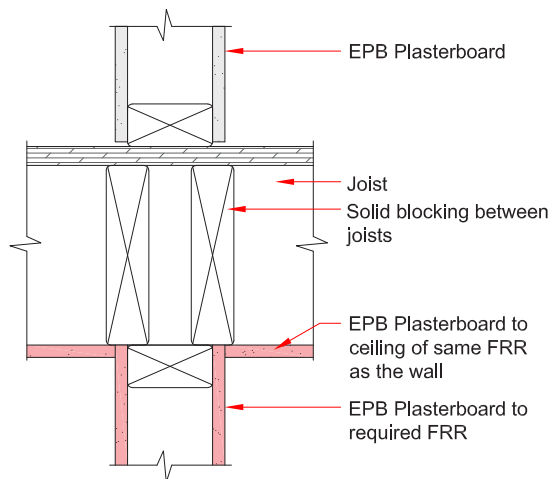

Wall & Floor/Ceiling Junctions

EFS-210

Junction of ceiling sheets Direct fixed to Timber Joist

- FRR of floor/ceiling is higher than the wall
- Difference in FRR is 30 minutes or less
- Non-load bearing wall

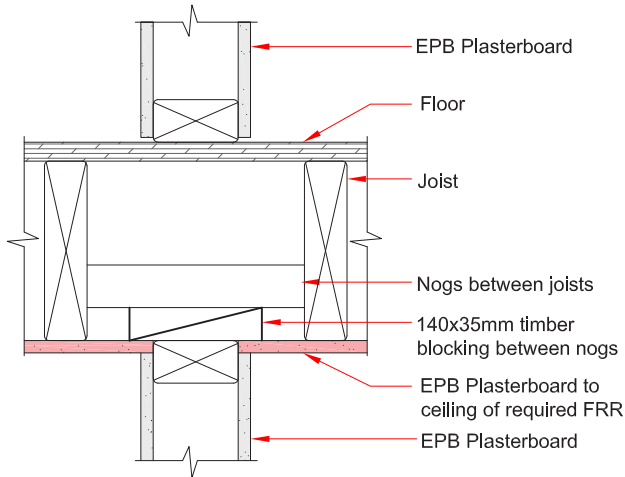

- FRR of floor/ceiling is higher than the wall
- Difference in FRR is 30 minutes or less
- Non-load bearing wall

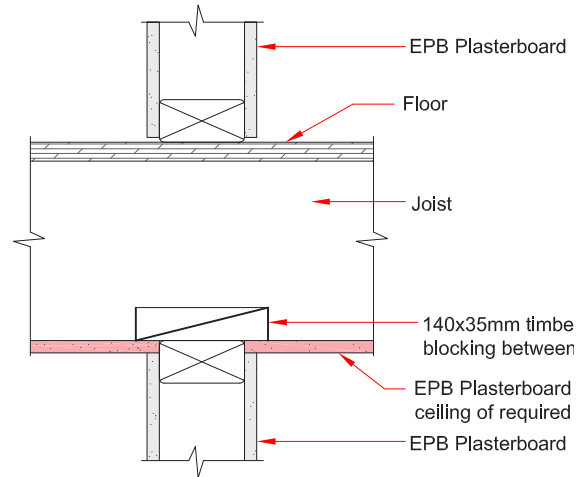

EFS-211

Junction of ceiling sheets Direct fixed to Timber Joist

- FRR of floor/ceiling is higher than the wall
- Difference in FRR is greater than 30 minutes
- Non-load bearing wall

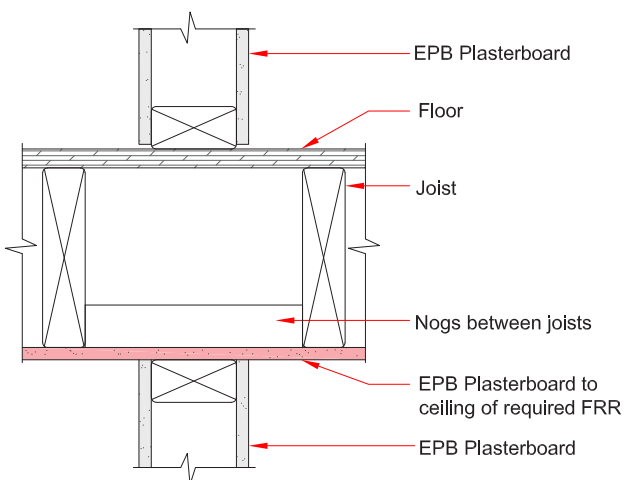

- FRR of floor/ceiling is higher than the wall
- Difference in FRR is greater than 30 minutes
- Non-load bearing wall

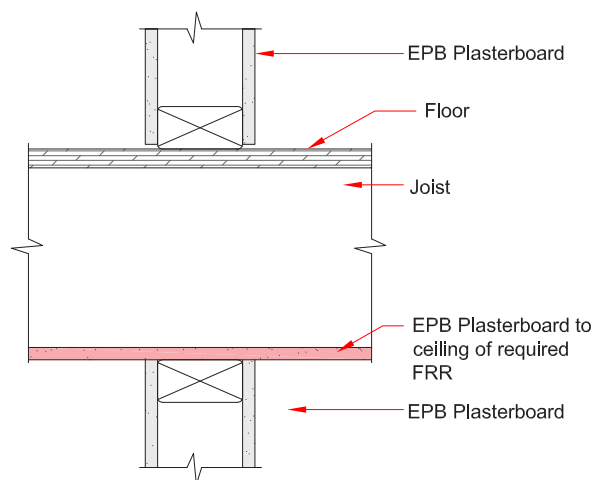

### Wall & Floor/Ceiling Junctions

EFS-212

#### Direct fix clip Floor/Ceiling Junction

- FRR of floor/ceiling & the wall are the same
- Load or Non-load bearing Wall
- In case of load bearing wall and it not being a fire cell, then it should be made a Universal wall in order to maintain structural stability.

- FRR of floor/ceiling & the wall are the same
- Load or Non-load bearing Wall
- In case of load bearing wall and it not being a fire cell, then it should be made a Universal wall in order to maintain structural stability.

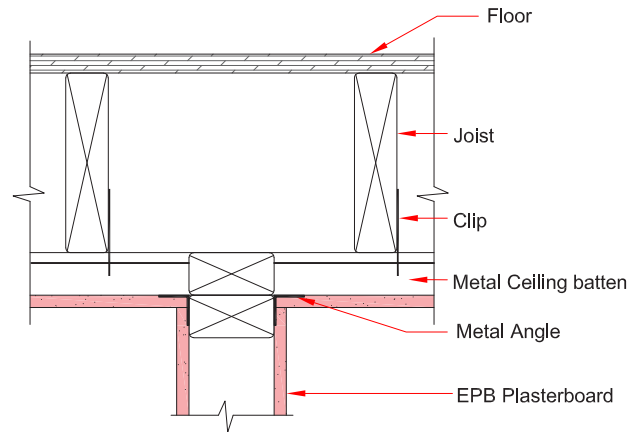
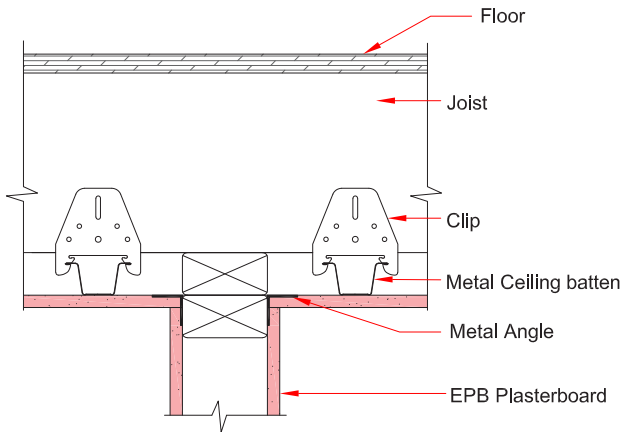

EFS-213

#### Direct fix clip Floor/Ceiling Junction

- FRR of floor/ceiling & the wall are the same
- Load or Non-load bearing Wall
- In case of load bearing wall and it not being a fire cell, then it should be made a Universal wall in order to maintain structural stability.

- FRR of floor/ceiling & the wall are the same
- Load or Non-load bearing Wall
- In case of load bearing wall and it not being a fire cell, then it should be made a Universal wall in order to maintain structural stability.

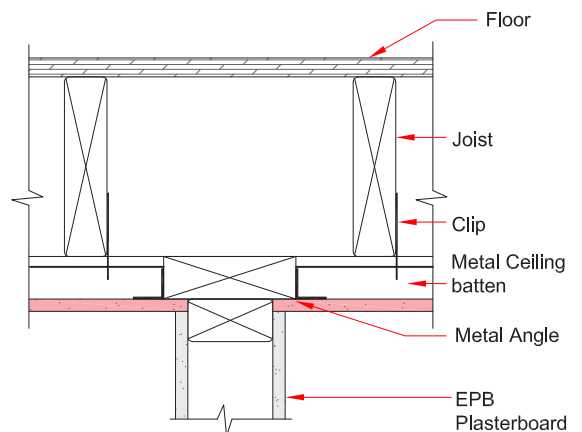
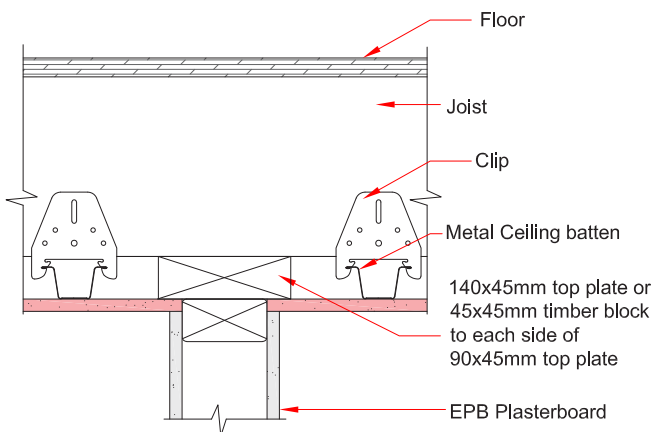

Wall & Floor/Ceiling Junctions

EFS-214

Direct fix clip Floor/Ceiling Junction

- FRR of floor/ceiling is higher than the wall
- Non-load bearing Wall

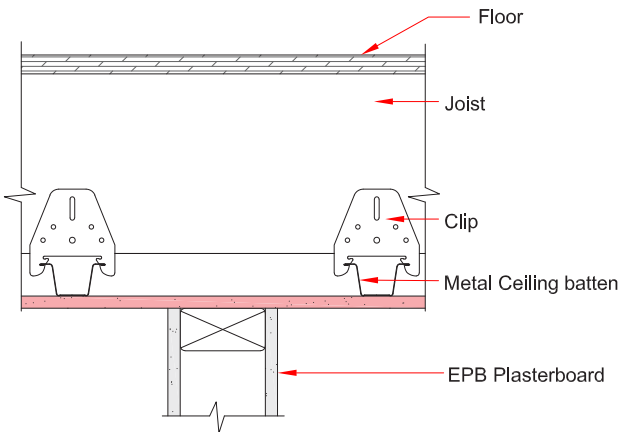

- FRR of floor/ceiling is higher than the wall
- Non-load bearing Wall

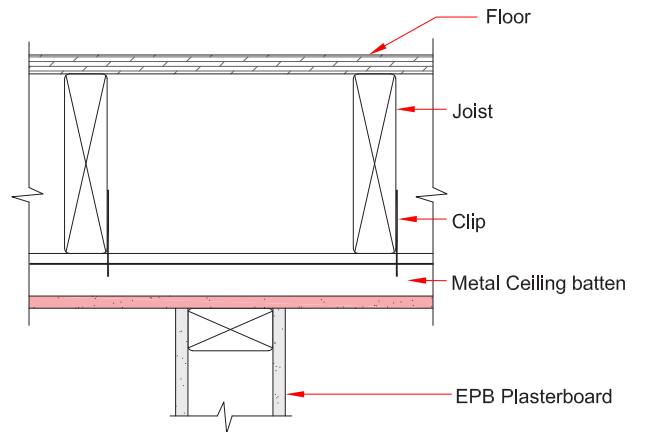

EFS-215

Direct fix clip Floor/Ceiling Junction

- FRR of floor/ceiling is higher than the wall
- Non-load bearing Wall

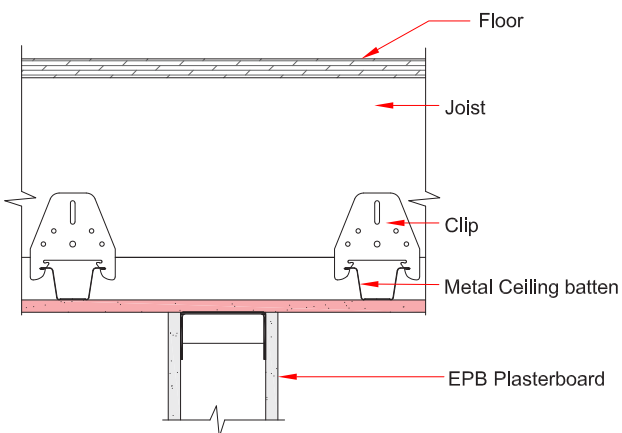

- FRR of floor/ceiling is higher than the wall
- Non-load bearing Wall

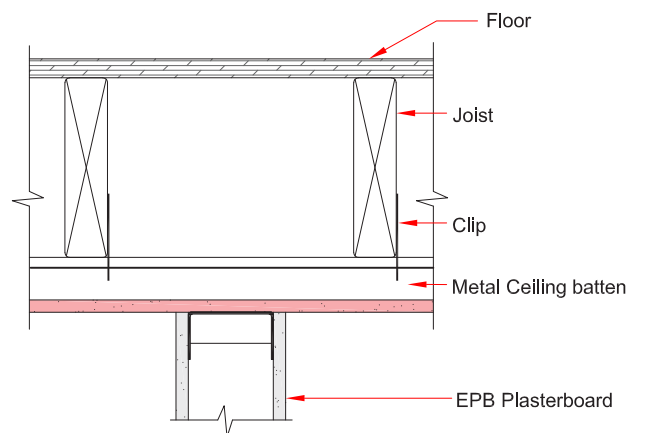

Head Details with Negligible Deflections

EFS-014

Head Detail for Steel or Timber Stud with Metal Top Track

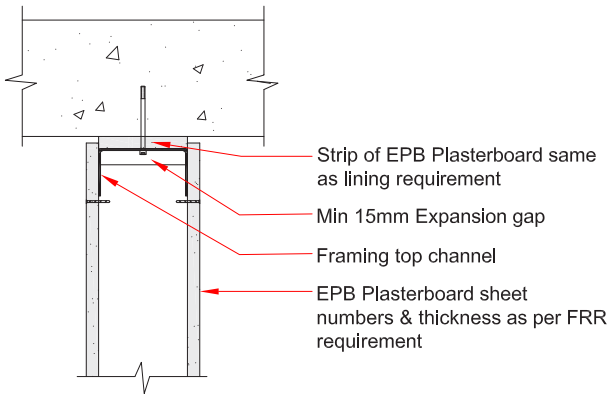

EFS-015

Head Detail for Steel or Timber Stud with Metal Top Track

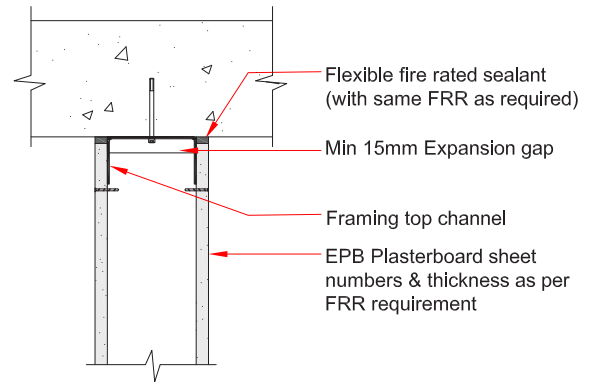

Note: Do not screw the wall lining into the top track

EFS-016

Head Detail for Full Timber frame - Type 1

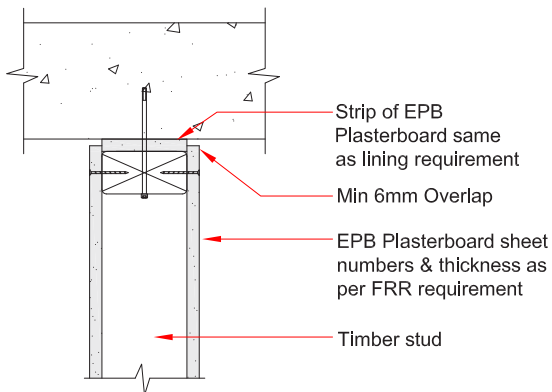

EFS-017

Head Detail for Full Timber frame - Type 2

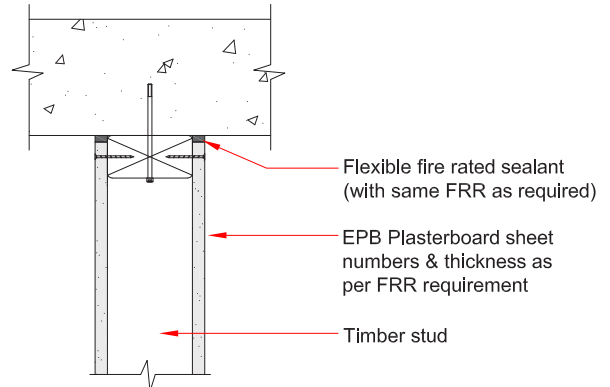

Base Details

EFS-058	Steel Frame	EFS-018	Timber Frame
---------	-------------	---------	--------------

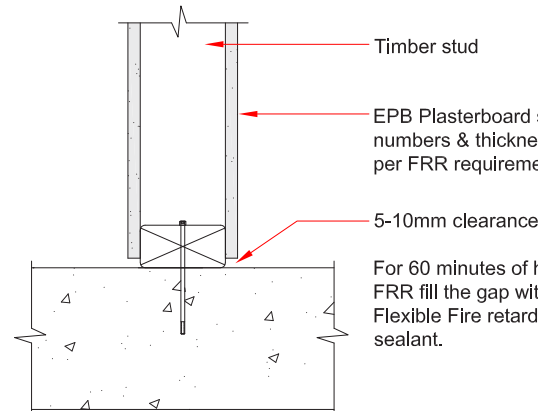
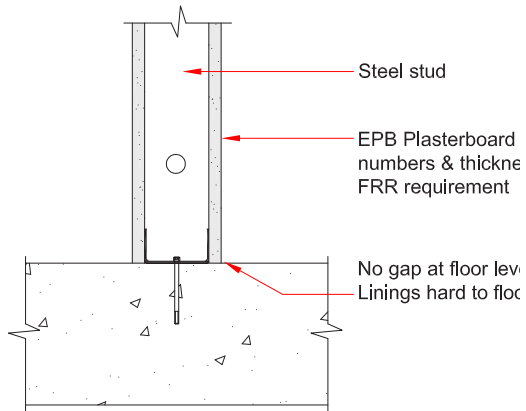

Rigid Junctions

EFS-004

Timber Stud Drywall to Masonry

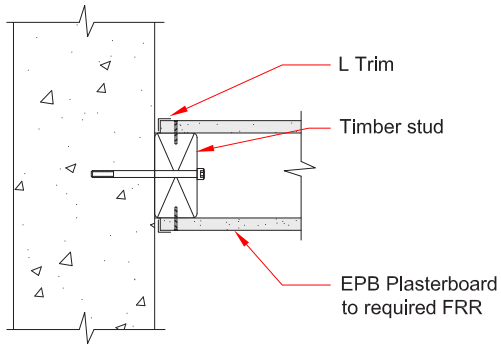

EFS-055

Steel Stud Drywall to Masonry

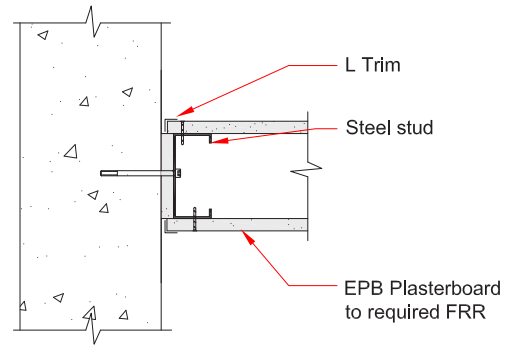

EFS-056

Steel Stud Drywall with FRR Wool Lining to Masonry

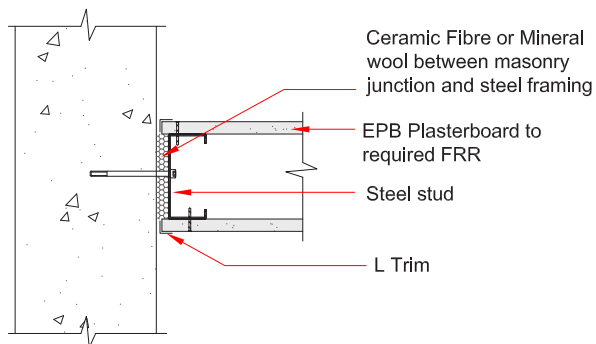

Deflection Head Details

EFS-008

Timber or Steel stud with Metal Top Track

Deflection (d) less than 20mm

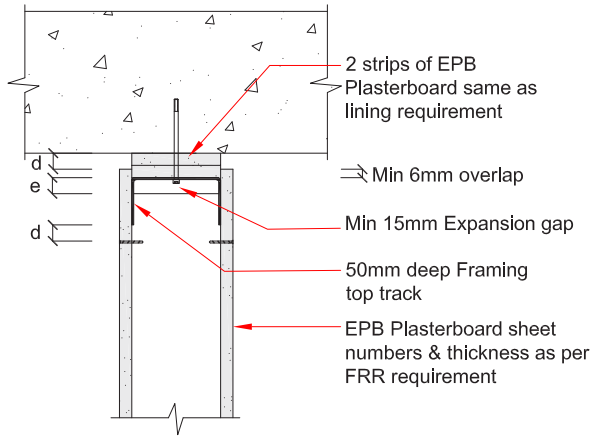

d = deflection  
e = expansion gap is the greater of 15mm or d

EFS-011

Timber or Steel stud with Metal Top Track

Deflection (d) less than 20mm with Fibre Cement or Timber block

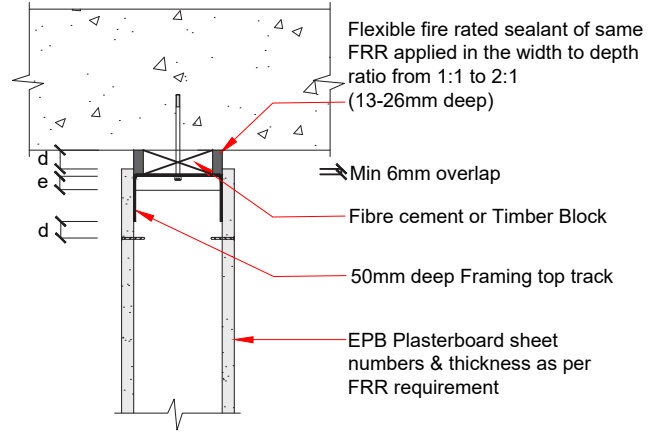

d = deflection  
e = expansion gap is the greater of 15mm or d

Note: If Plasterboard is cantilevered 75mm or more past the top screw then a cover strip must be added

EFS-009

Timber or Steel stud with Metal Top Track

Deflection (d) 20mm or greater

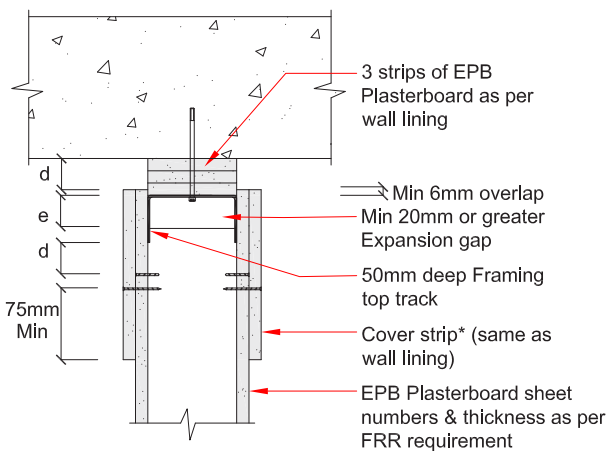

d = deflection  
e = expansion gap is the greater of 15mm or d

\*Note: If plasterboard is cantilevered 75mm or more past the top screw, then a cover strip must be added

EFS-010

Timber or Steel stud with Metal Top Track

Deflection (d) 20mm or greater with Fibre Cement or Timber block

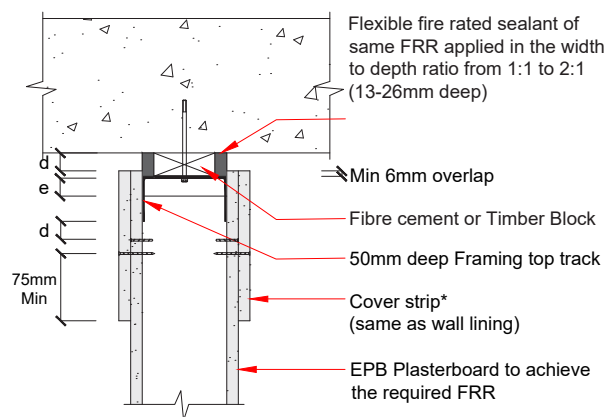

d = deflection  
e = expansion gap is the greater of 15mm or d

Note: If plasterboard is cantilevered 75mm or more past the top screw, then a cover strip must be added



Deflection Head Details

EFS-012

Full Timber Frame with Metal Top Track -Type 1

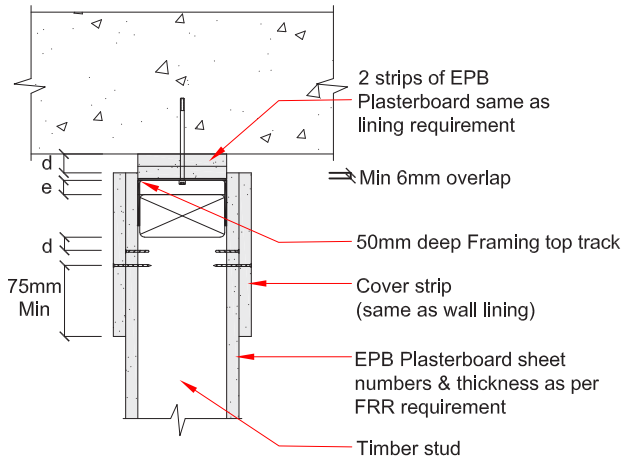

d = deflection  
 e = expansion gap is the greater of 15mm or d  
 \*Note: If Plasterboard is cantilevered 75mm or more past the top screw use additional cover strip

EFS-013

Full Timber Frame with Metal Top Track -Type 2

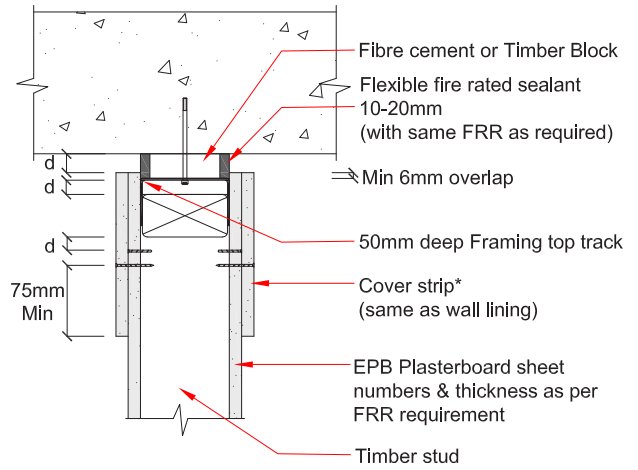

d = deflection  
 e = expansion gap is the greater of 15mm or d  
 \*Note: If Plasterboard is cantilevered 75mm or more past the top screw use additional cover strip



Composite Floor Deflection Head Details

EF5-251

ComFlor® Detail for Wall Perpendicular to Profile Junction

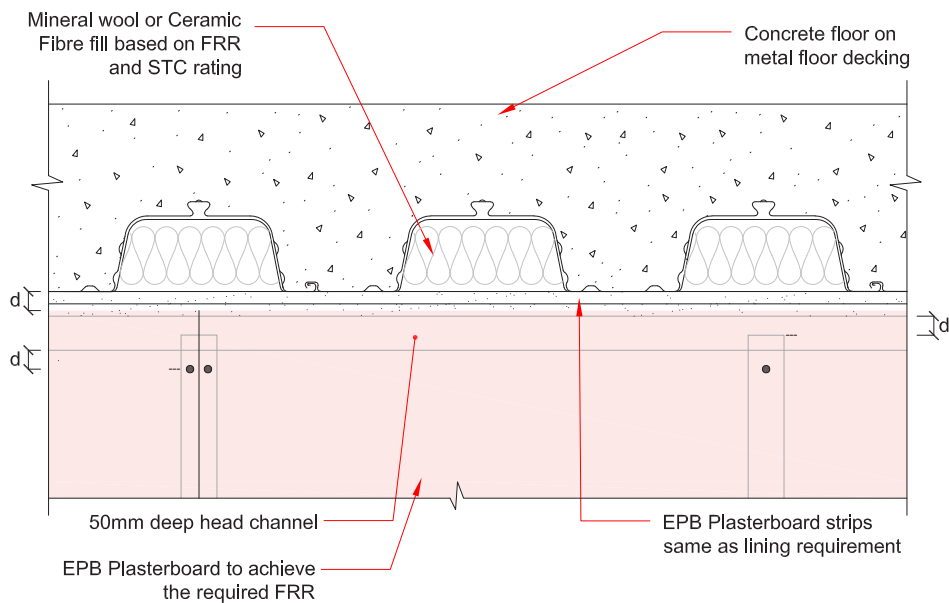

d = Deflection

Note: If Plasterboard is cantilevered 75mm or more past the top screw then wall lining must be double layer

**NOTE:** Maximum 60 mins Fire system only. For higher fire rating requirements, contact Elephant Plasterboard (NZ) Ltd at 0800 353 742

EF5-254

ComFlor® Detail for Wall to Profile Junction

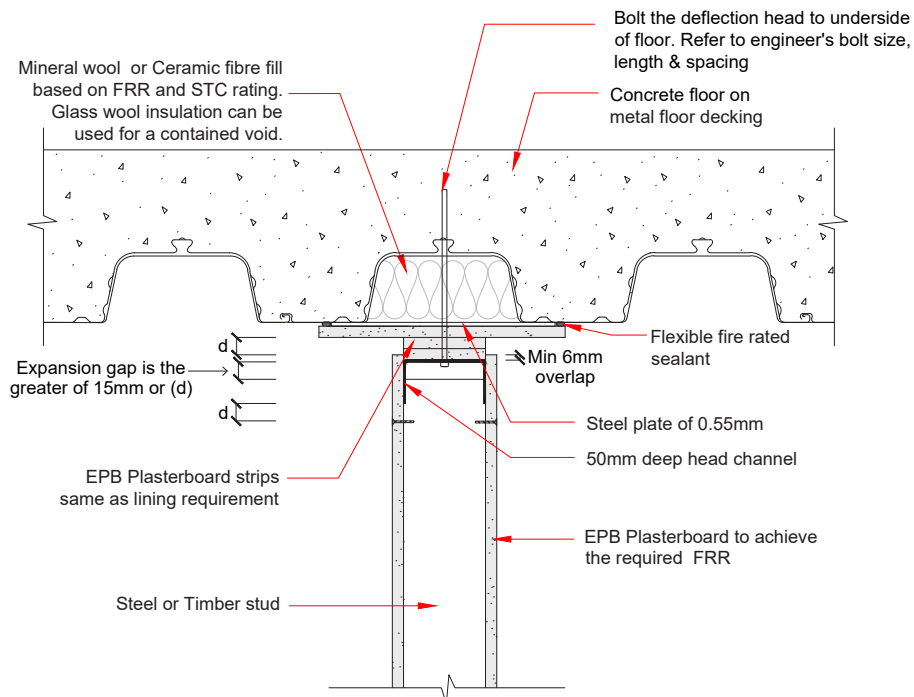

d = Deflection

Note: If Plasterboard is cantilevered 75mm or more past the top screw then wall lining must be double layer

**NOTE:** Maximum 60 mins Fire system only. For higher fire rating requirements, contact Elephant Plasterboard (NZ) Ltd at 0800 353 742



Composite Floor Deflection Head Details

EFS-263

ComFlor® Detail for Wall to Profile Junction with Timber packer

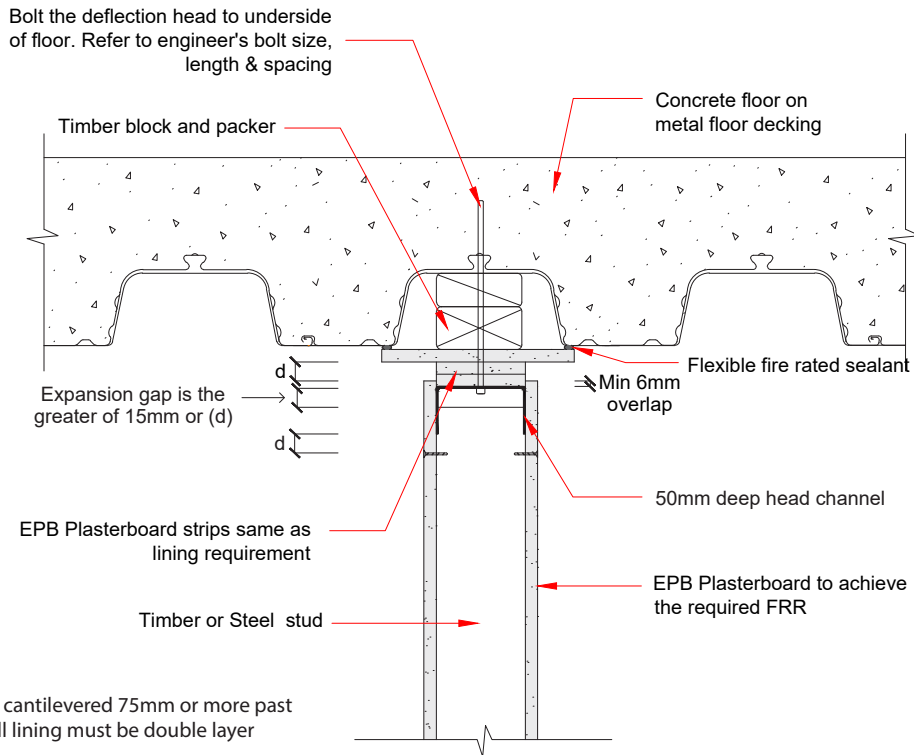

**NOTE:** Maximum 60 mins Fire system only. For higher fire rating requirements, contact Elephant Plasterboard (NZ) Ltd at 0800 353 742

EFS-257

ComFlor® Detail for Wall to Profile Junction

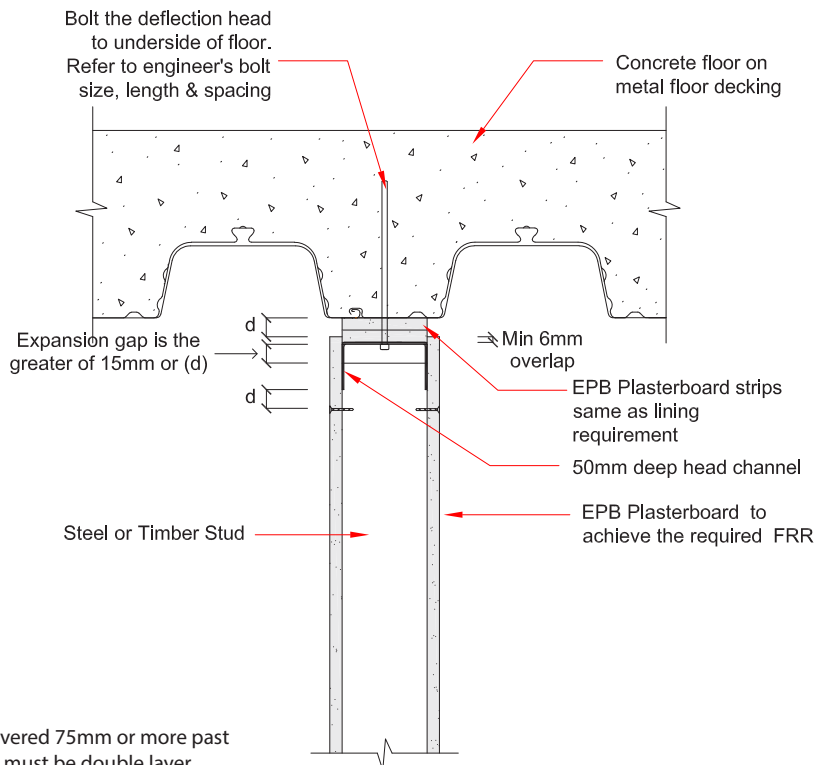

**NOTE:** Maximum 60 mins Fire system only. For higher fire rating requirements, contact Elephant Plasterboard (NZ) Ltd at 0800 353 742



Composite Floor Deflection Head Details

EF5-261

ComFlor® Detail for Wall to Profile Junction

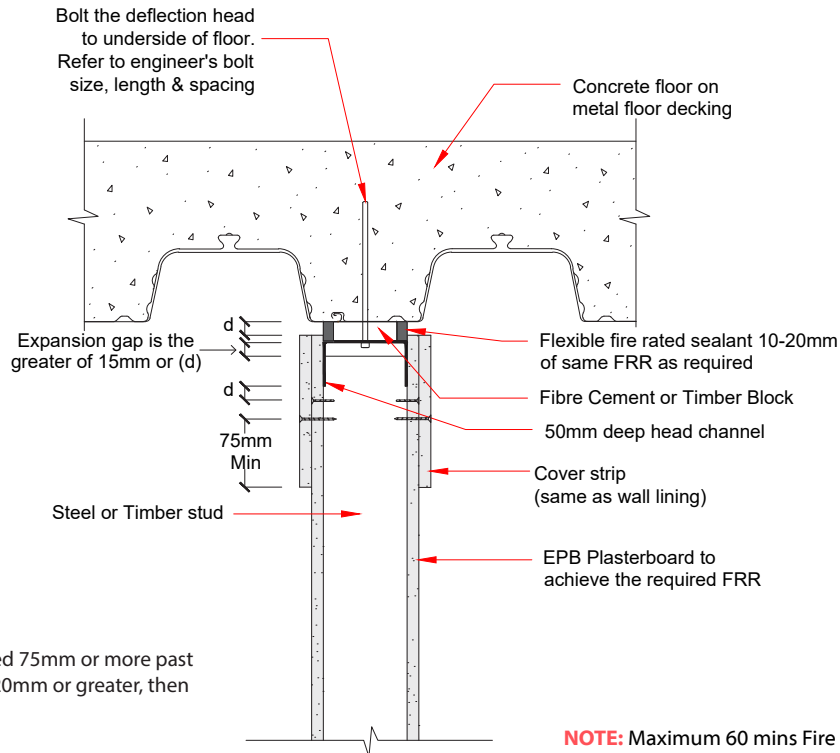

d = Deflection

Note: If Plasterboard is cantilevered 75mm or more past the top screw or deflection (d) is 20mm or greater, then cover strip must be added

**NOTE:** Maximum 60 mins Fire system only. For higher fire rating requirements, contact Elephant Plasterboard (NZ) Ltd at 0800 353 742

EF5-256

ComFlor® Detail for Wall Perpendicular to Profile Junction - For Negligible Deflection

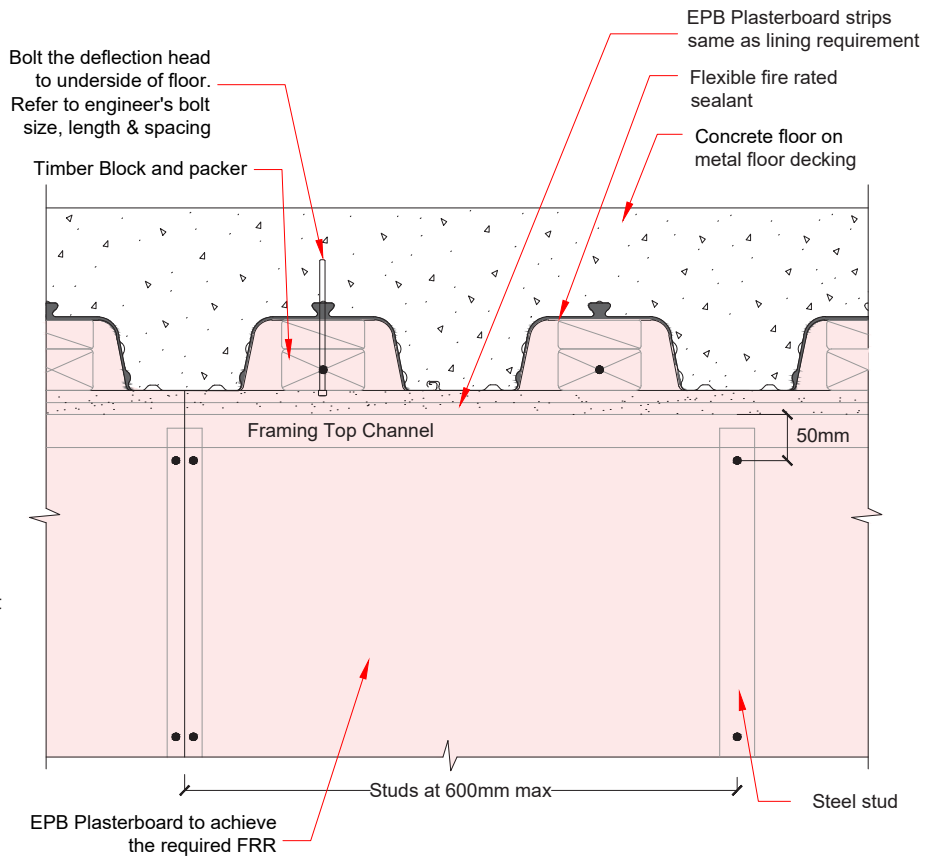

Note: If Plasterboard is cantilevered 75mm or more past the top screw or deflection (d) is 20mm or greater, then cover strip must be added

**NOTE:** Maximum 60 mins Fire system only. For higher fire rating requirements, contact Elephant Plasterboard (NZ) Ltd at 0800 353 742



Roof Details

EF5-203

Intersection Roof Details

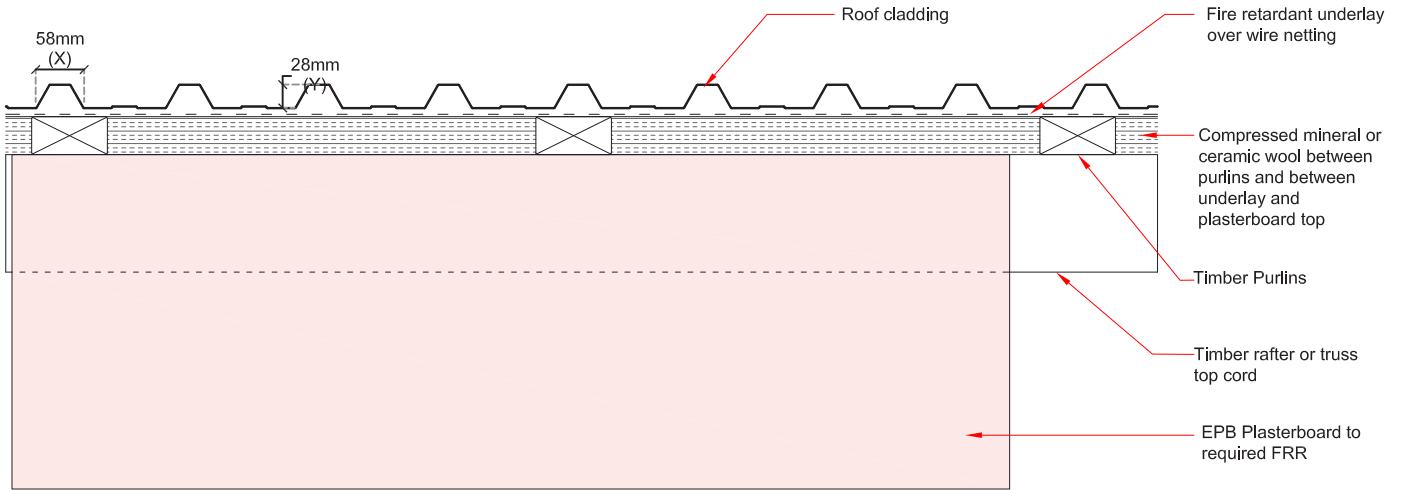

**Intersection Roof Detail**  
 (with plasterboard running parallel to  
 timber rafters/roof battens)

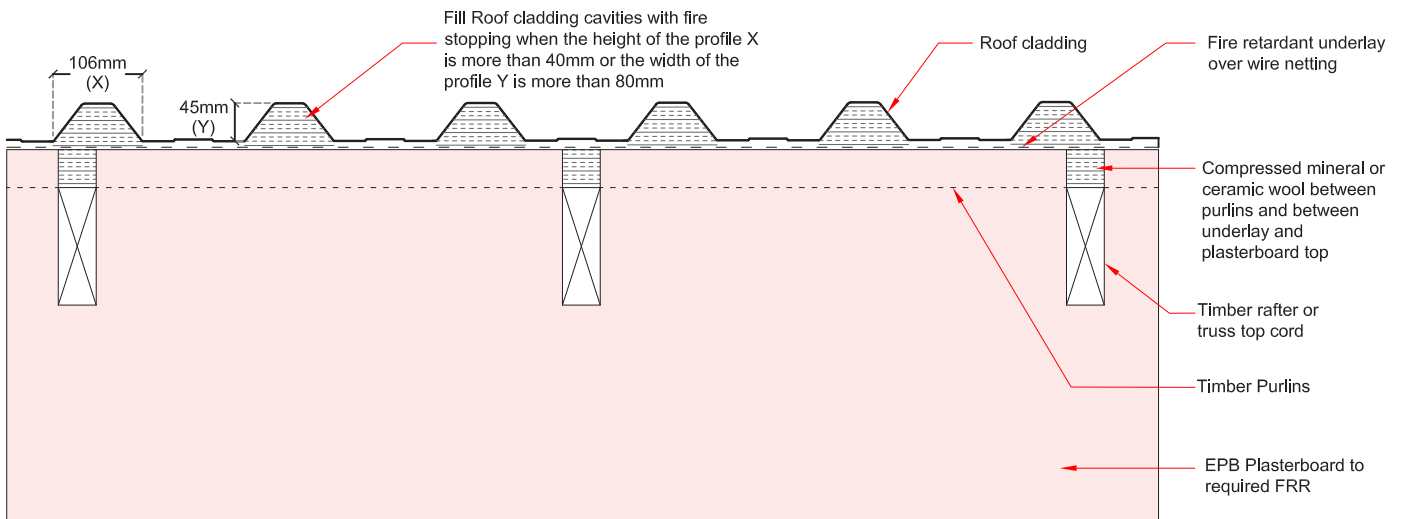

**Intersection Roof Detail**  
 (with plasterboard running perpendicular to  
 timber rafters/roof battens)



## Penetrations

Penetrations in Fire Rated Walls is a potential hazard of flame and smoke spreading from one fire cell to other in building occupancies. Ensuring the right penetration seals will help in maintaining the FRR of the Fire system and thereby maintaining the health and security of the occupants.

### Generic Penetration Details

This section contains the general principle of penetrations and the most common installation details of one-sided penetrations on EPB Plasterboard Fire Rated systems.

### Proprietary Penetration Seals

Fire rated penetration details using proprietary penetrations seals and products (such as GPO's with intumescent pads, fire collars, dampers etc) must be installed in accordance with requirements from particular product manufacturers, and are not shown in this manual.

Installation instructions and product performance specifications must be verified with the relevant penetration seal manufacturer. It is the responsibility of the component manufacturer to ensure that the fire rating performance of the system is not affected.

EFS-158

### Cable Penetration for Surface Mounted Electrical Fixtures

Plan View

Ceiling Section

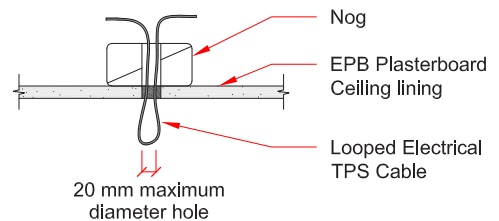
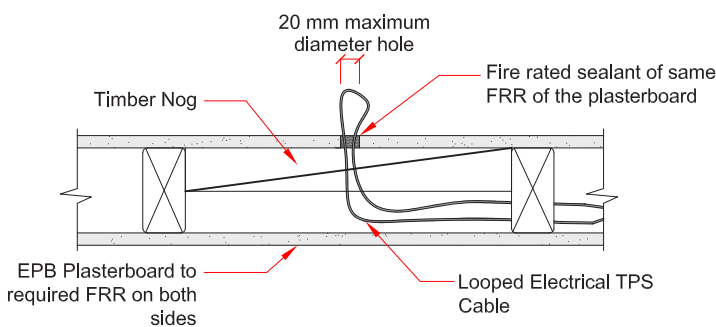
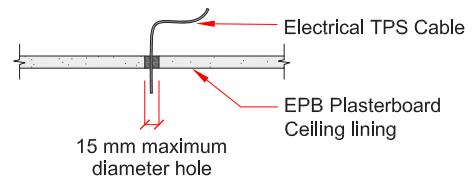
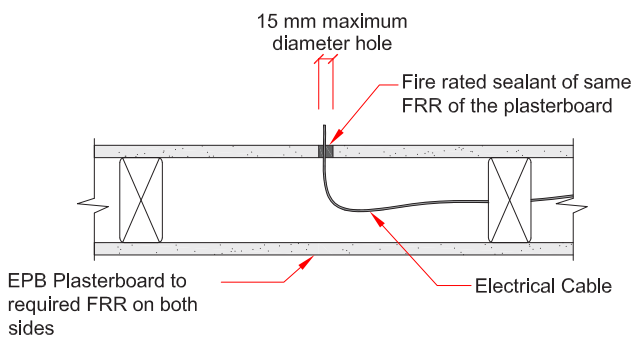

*Note: Refer proprietary products & penetration seal manufacturer's specifications & limitations for larger holes*



Penetrations

EF5-155

Metal Pipe on Steel Frame Wall

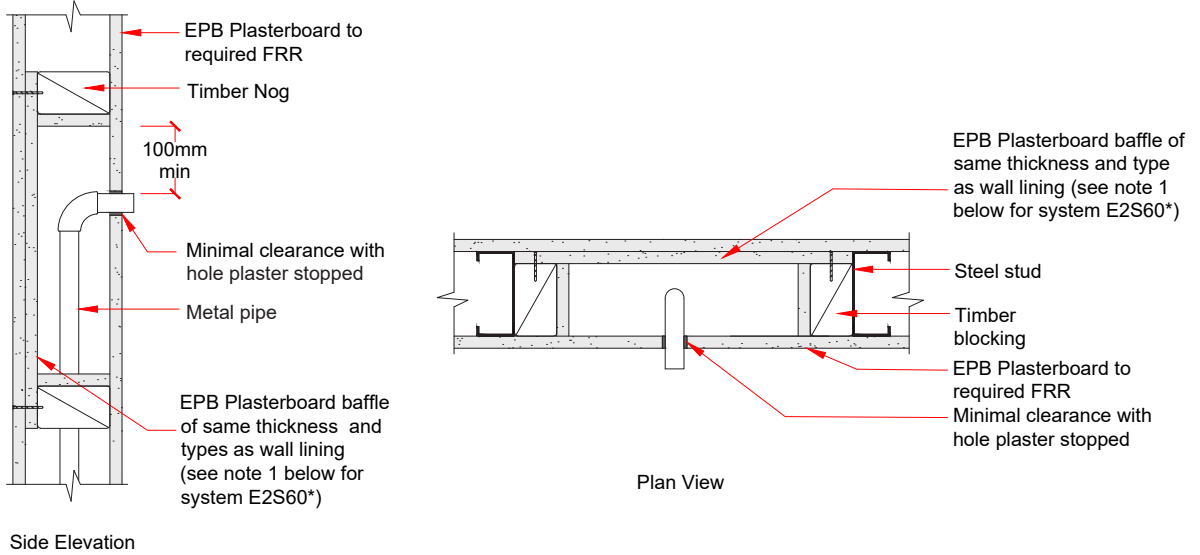

\*Note:

1. In order to maintain the 60 minutes FRR in system E2S60, the baffle must be minimum 16mm EPB FireSmart
2. Refer proprietary products & penetration seal manufacturer's specifications & limitations for larger holes

EF5-156

Metal Pipe on Timber Frame Wall

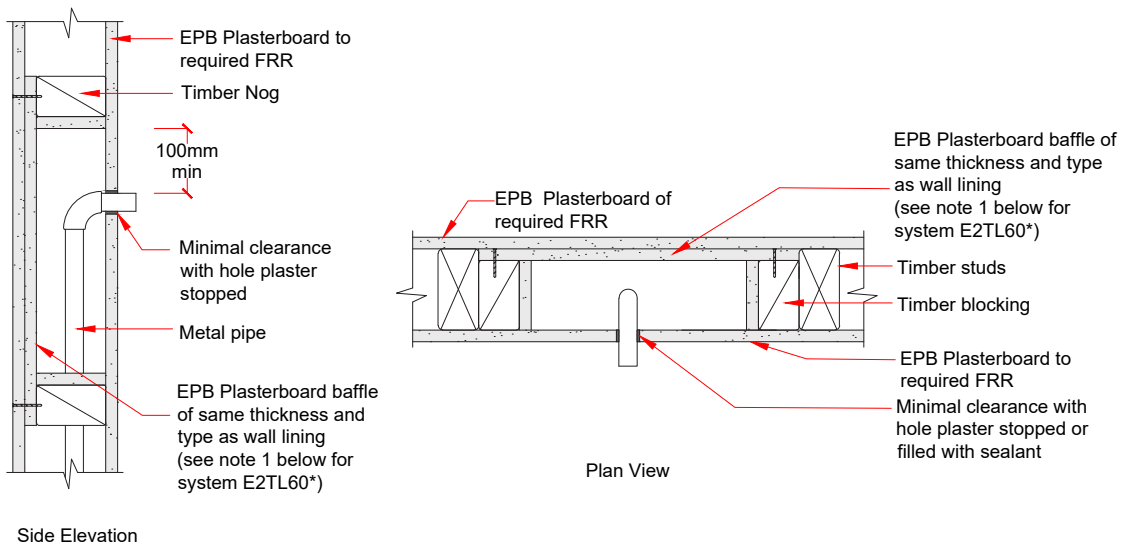

\*Note:

1. In order to maintain the 60 minutes FRR in system E2TL60, the baffle must be minimum 16mm EPB FireSmart
2. Refer proprietary products & penetration seal manufacturer's specifications & limitations for larger holes



Penetrations

EFS-151

Flush Box on Steel Frame Wall

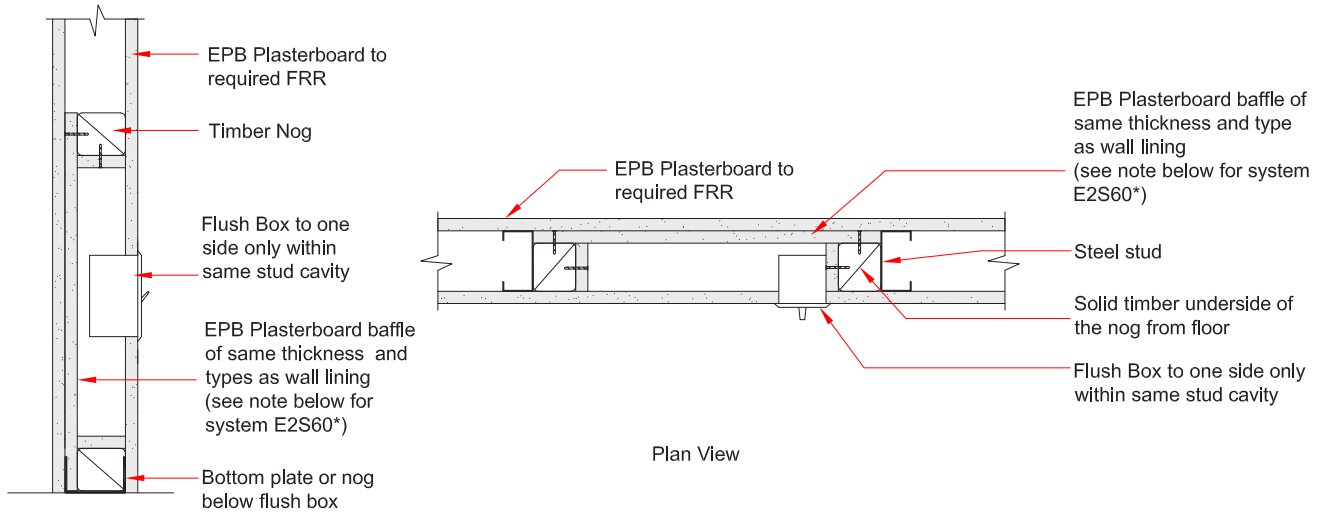

Side Elevation

Plan View

\*Note: In order to maintain the 60 minutes FRR in system E2S60, the baffle must be minimum 16mm EPB FireSmart

EFS-152

Flush Box on Timber Frame Wall

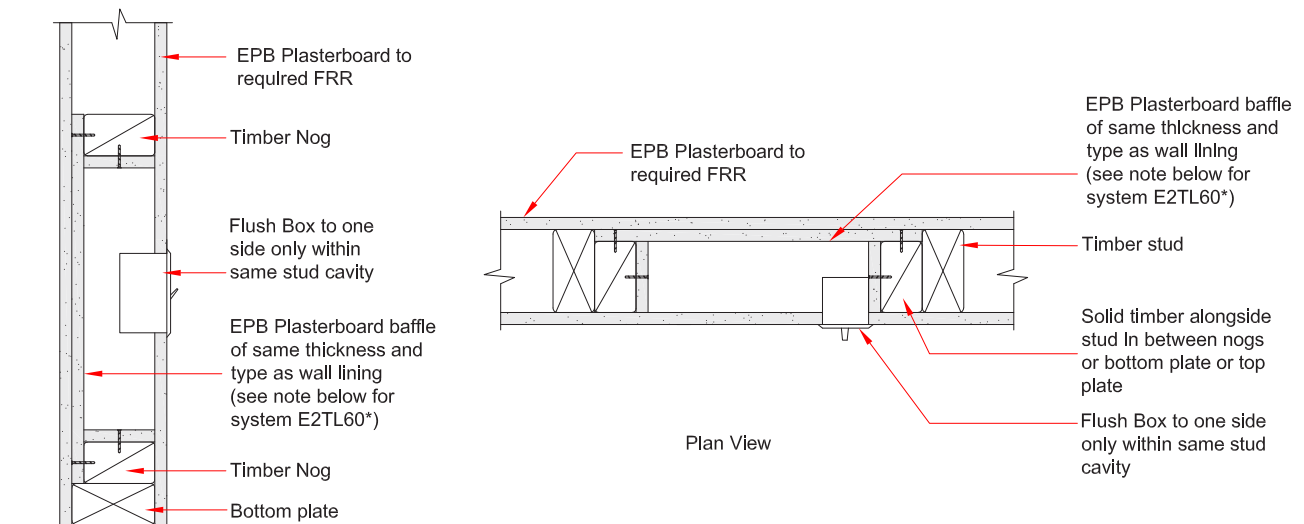

Side Elevation

Plan View

\*Note: In order to maintain the 60 minutes FRR in system E2TL60, the baffle must be minimum 16mm EPB FireSmart



Penetrations

EFS-154

Large Recess on Steel Frame Wall

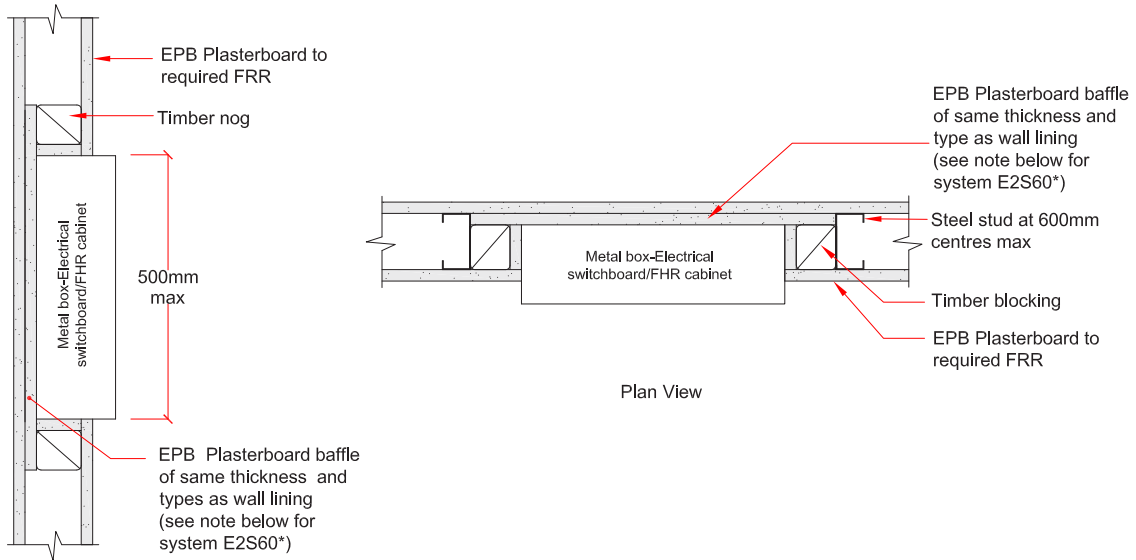

Side Elevation

\*Note: In order to maintain the 60 minutes FRR in system E2S60, the baffle must be minimum 16mm EPB FireSmart

EFS-153

Large Recess on Timber Frame Wall

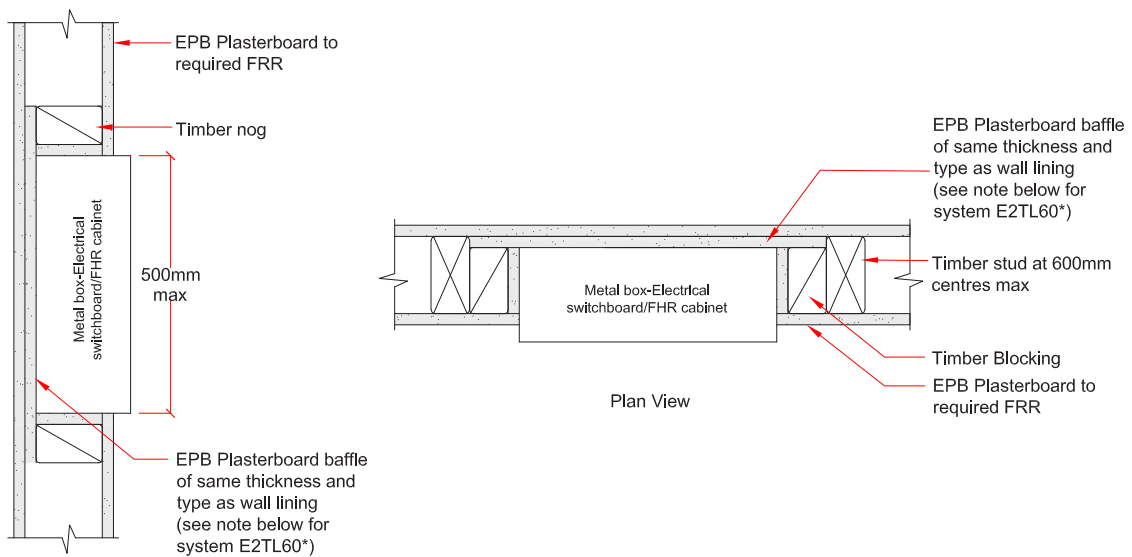

Side Elevation

\*Note: In order to maintain the 60 minutes FRR in system E2TL60, the baffle must be minimum 16mm EPB FireSmart



Penetrations

EFS-160

Recessed Light Ceiling Penetration

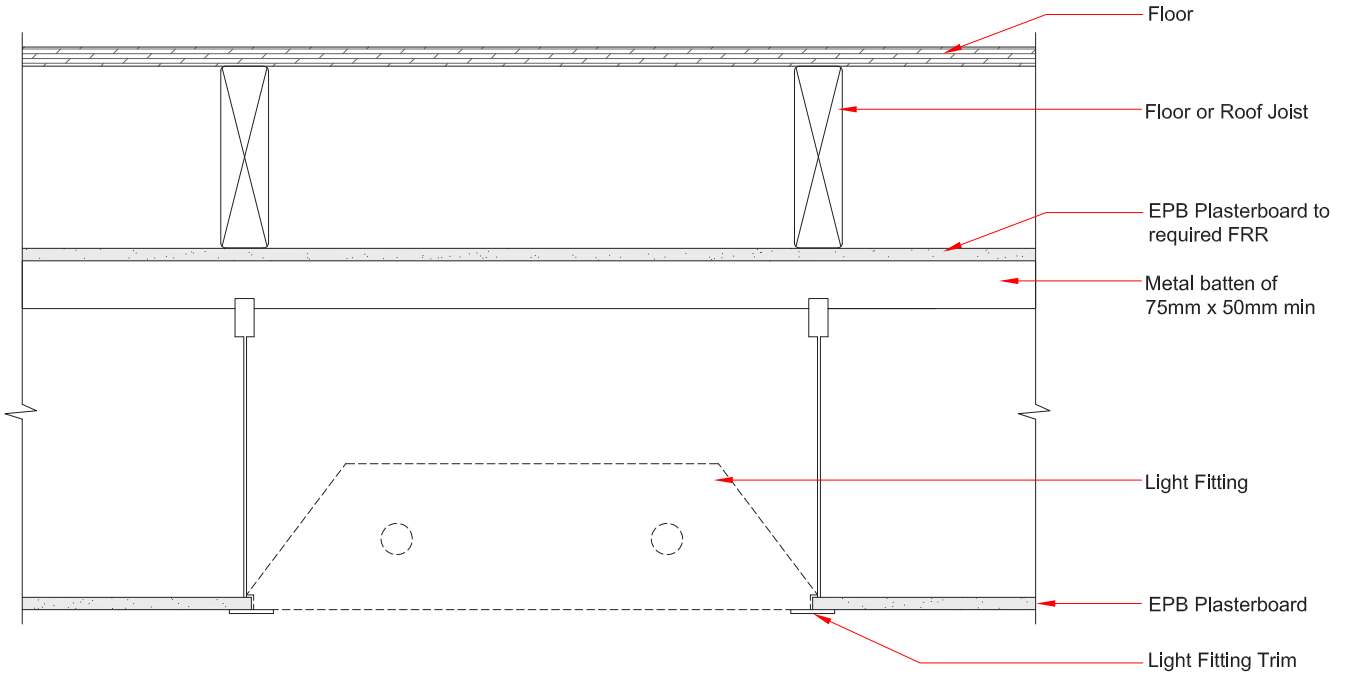

EFS-159

Recessed Light Ceiling Penetration

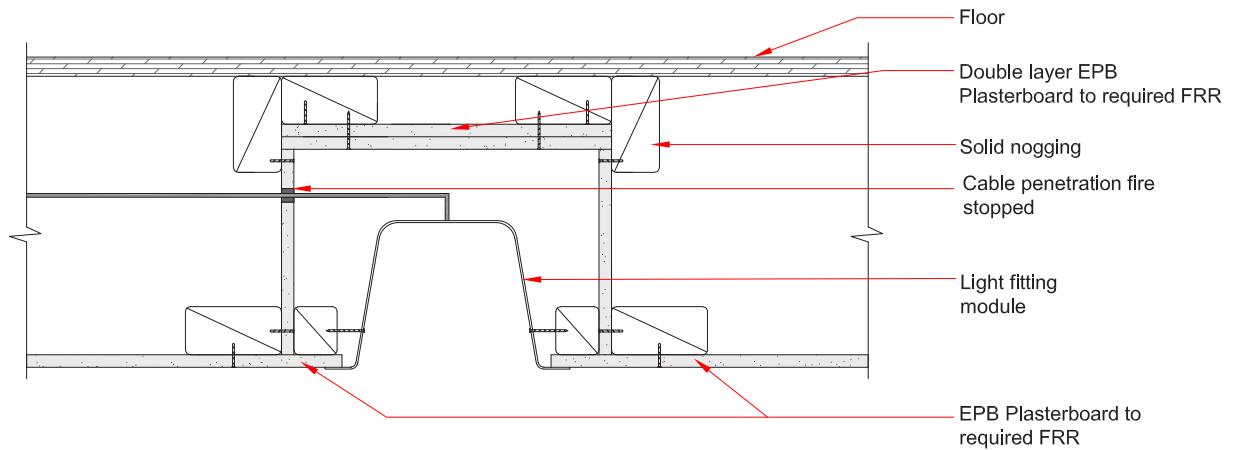

Penetrations

EPB-165

Services within non load bearing wall passing through ceiling top plate

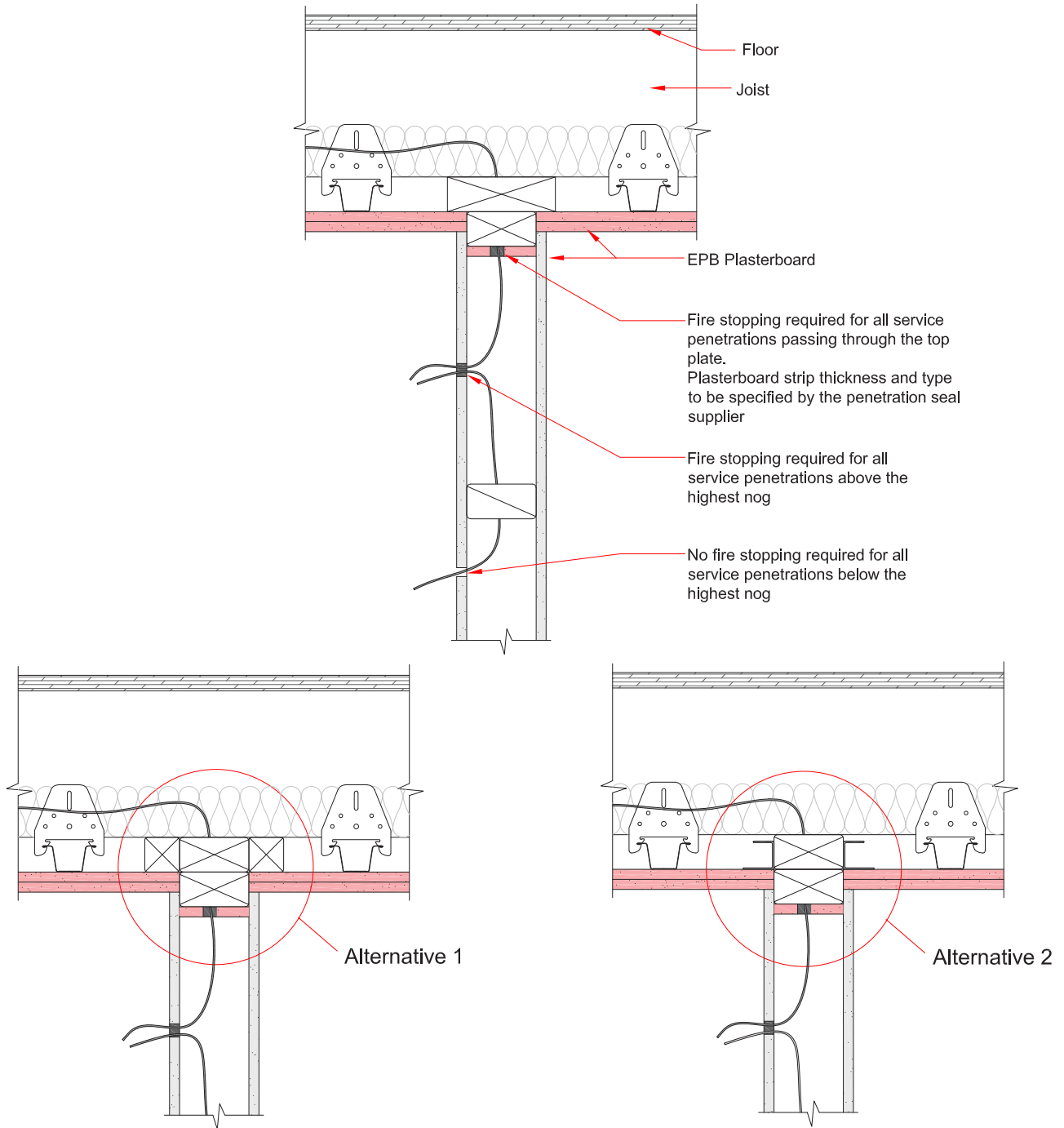

- FRR of floor/ceiling is 60 minutes or less
- FRR of the wall is 30 minutes or more
- Non load bearing wall



Penetrations

EF5-164

Services within Load bearing wall passing through ceiling top plate

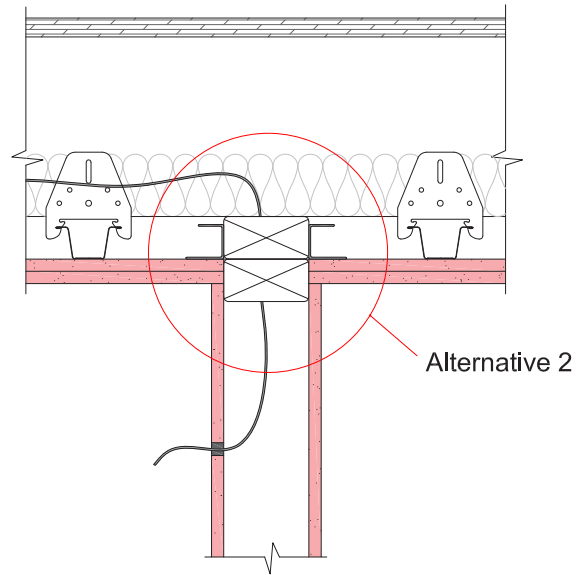
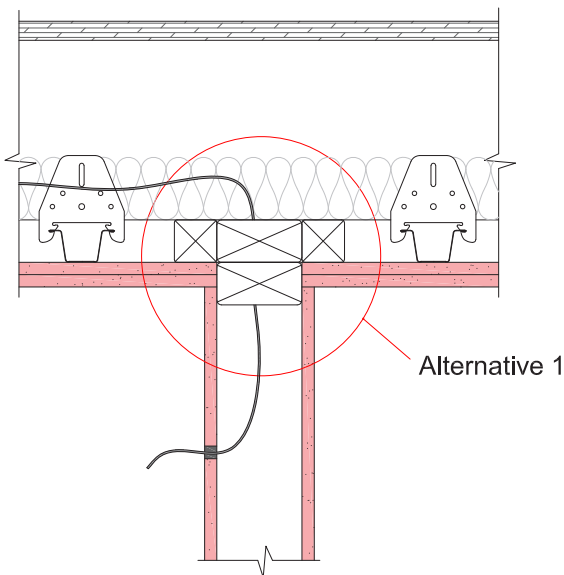
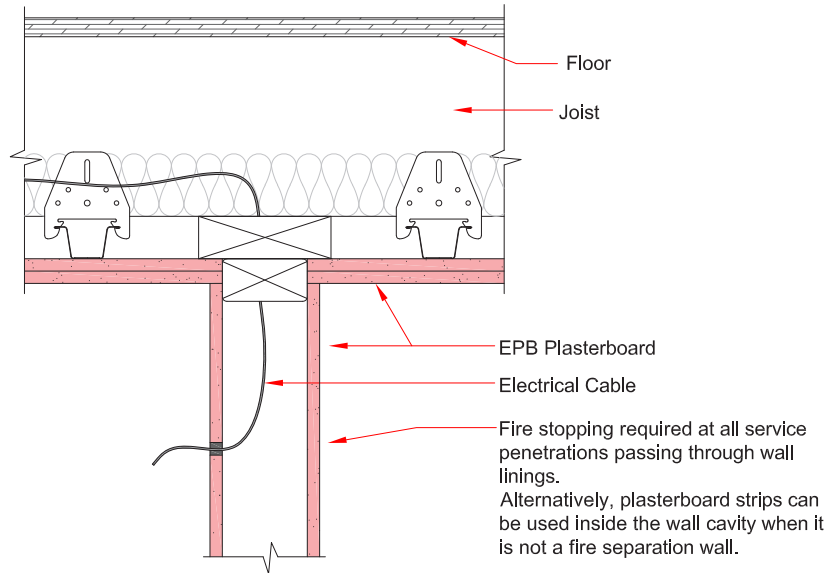

- FRR of floor/ceiling & the wall are the same
- Load bearing Wall
- In case of simultaneous fire exposure on both sides, E2TL30S, E4TL60S or Universal wall one-way FRR systems to both sides can be used unless specific design is needed in order to maintain structural adequacy.



## Proprietary Penetration Seals

### Design Stage

- The engineer/architect must ensure that the fire rated service penetrations are correctly specified in the building plan.
- The design team must ensure that fire engineer's details and specifications are incorporated into the overall design as part of the building consent documentation.
- It is advisable to combine many services as possible into a fire rated shaft or service highways hence avoiding multiple individual penetrations that could compromise the fire rating.
- Correct specification of service penetrations requires understanding of test reports, evaluations and limitations of applicability. eg. the fire test result of the penetration seals tested on a concrete wall will require separate verification to be installed on a framed wall lined with plasterboard.
- In all cases ensure that the manufacturer's specifications must be followed, particularly paying attention to specific application, wall types and fixing methods.

### Penetration Seal support

- Support penetration seals by additional framing members around the aperture if required.
- Alternatively, for penetration seals such as small metal pipes, plastic collar pipes or cable bundles, additional patches of plasterboard can be installed over the existing layer of wall linings, supported by the adjacent framing members.
- One way universal wall or ceiling systems do not require wall patches when penetration seals are installed.
- For heavy penetrations such as cable trays and ducts, separate support is required as per the penetration seal manufacturer's specification.
- In scenarios where there are multiple penetrations above the ceiling level, it is advisable to add an additional continuous strip of plasterboard over the existing wall lining to ensure strengthening around that area.

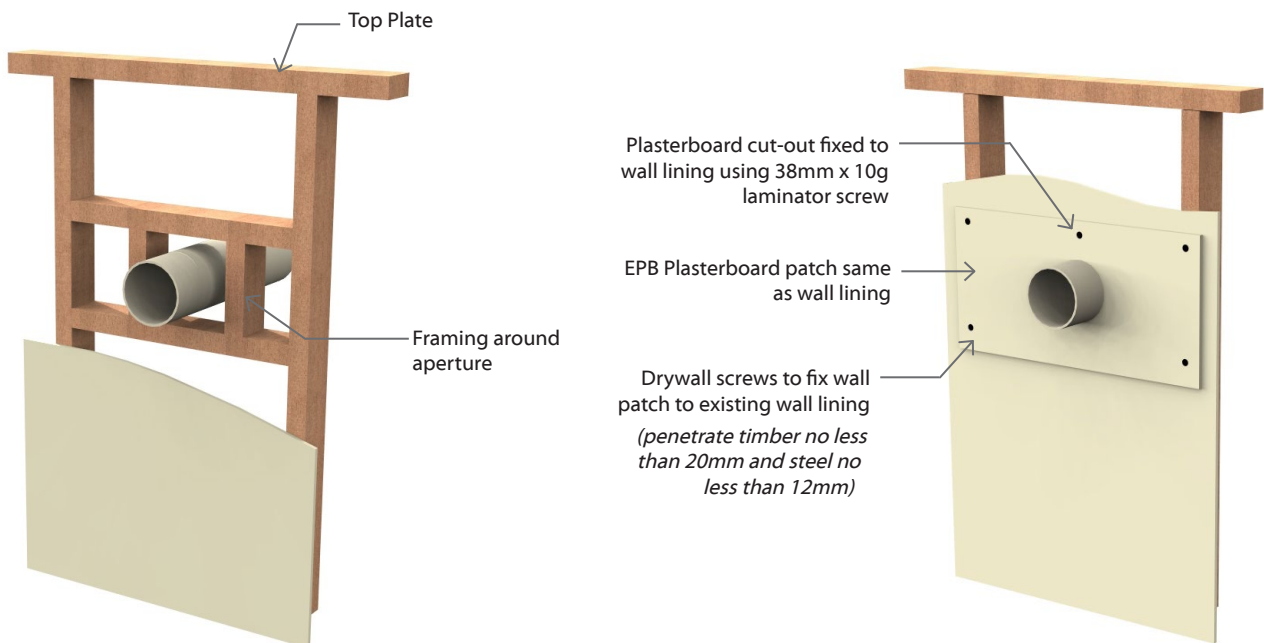
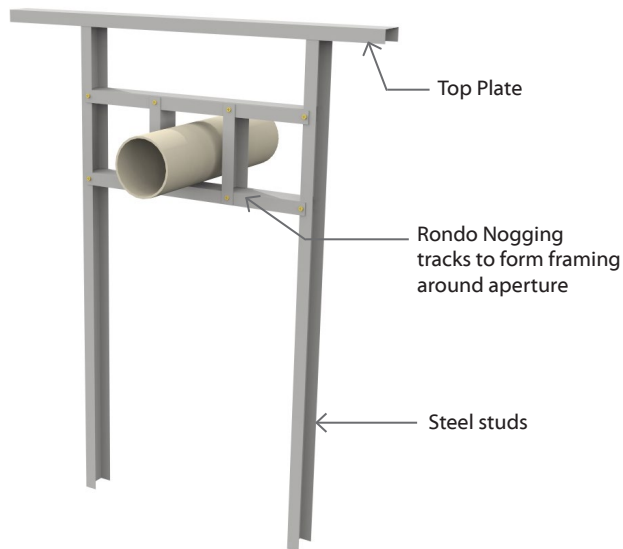

Wall & Floor/Ceiling Junctions

FFS-207

Floor/Ceiling Junction - Split level

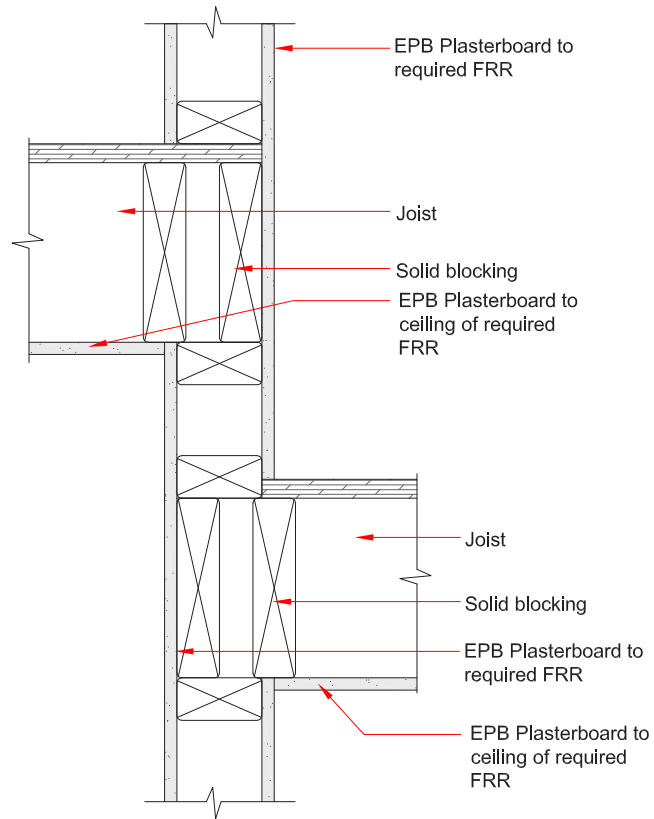

Ceiling Wall Junction Details

EFS-201

Suspended Ceiling Details

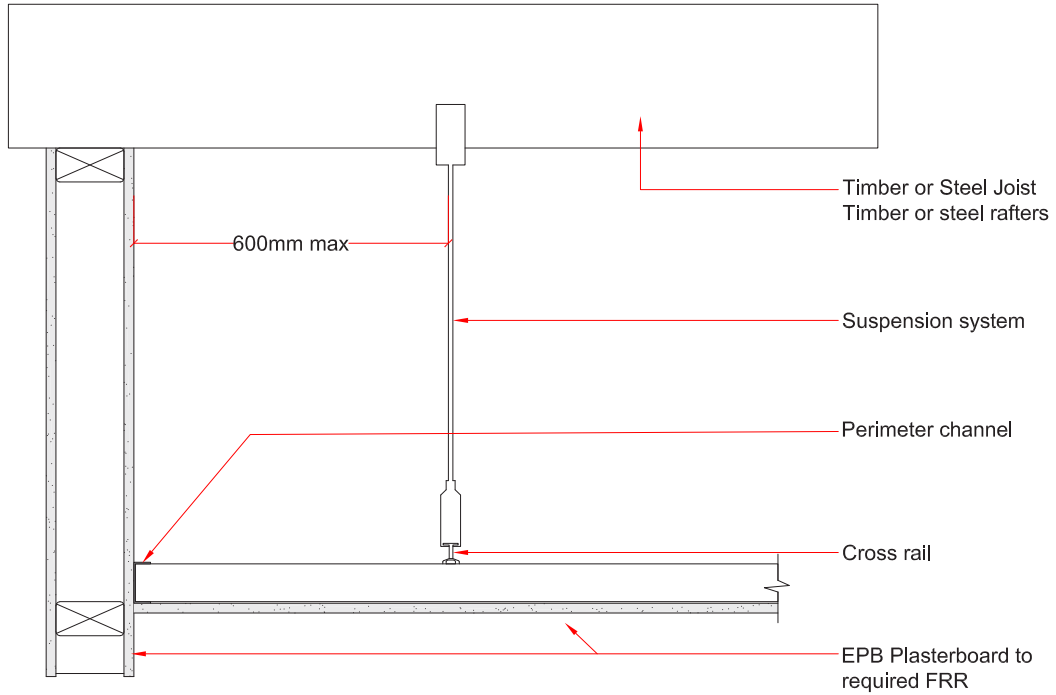

EFS-202

Direct Fix Clip Ceiling Details

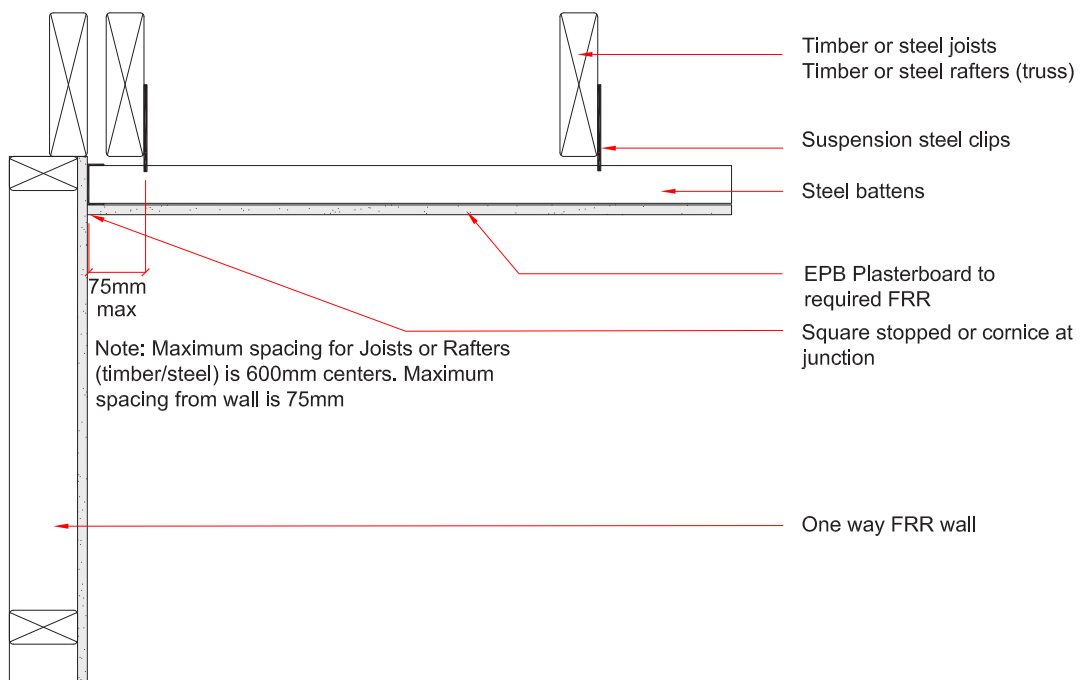

Shaftwall

EFS-301

Shaftwall Head & Base Detail

Elevation

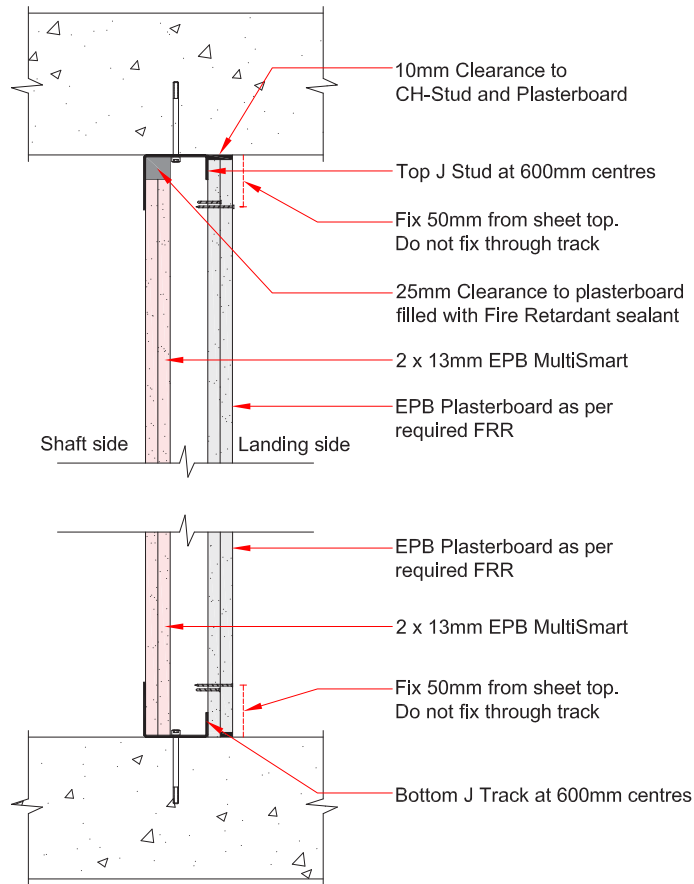

EFS-304

Shaftwall Construction Detail

Plan View

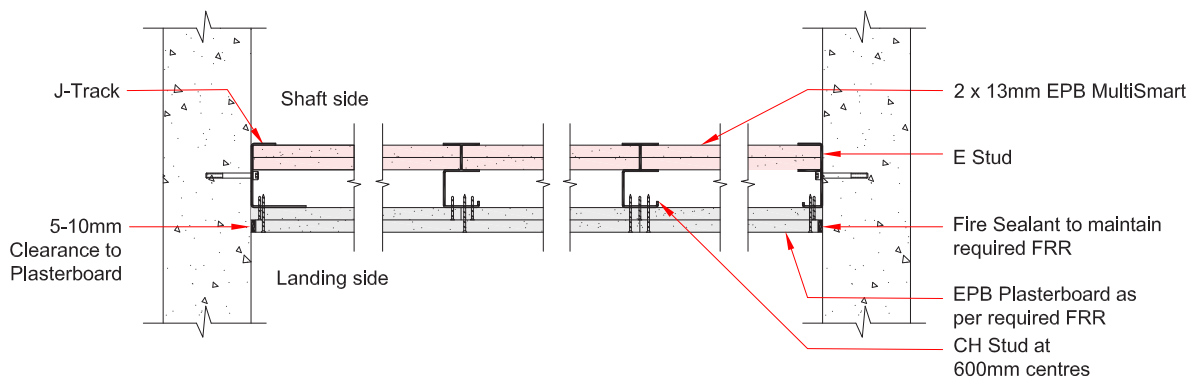

Shaftwall

EFB-305  
EFB-306

Shaftwall Corner Junctions

Plan View

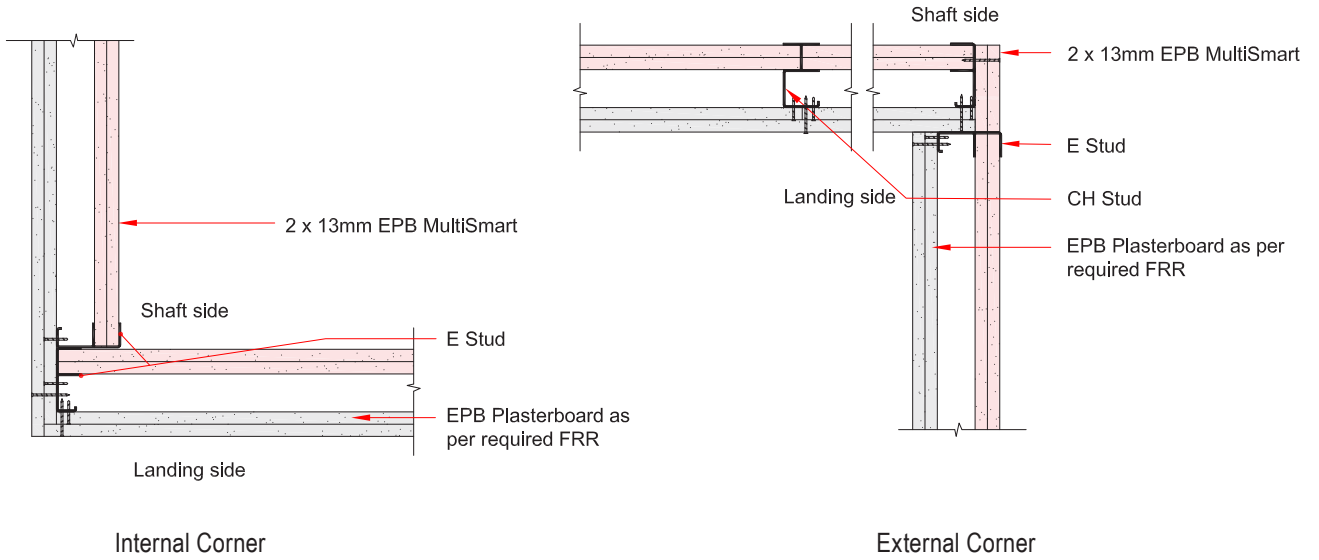

EFB-307

Intersecting Shaftwall Junction

Plan View

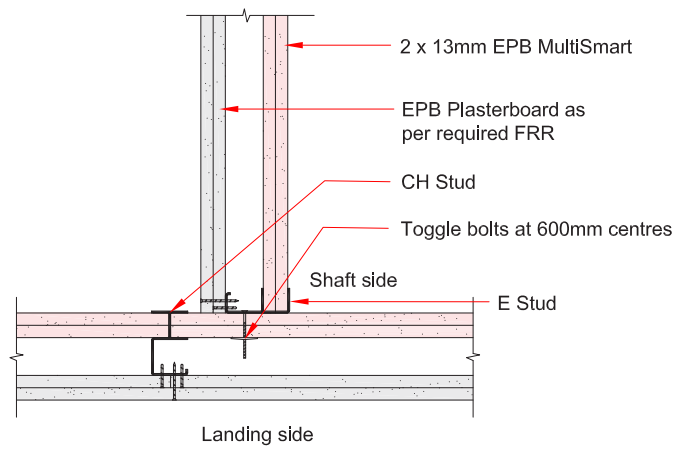

### Boundary Wall

Elephant Fire Rated Plasterboard systems may be used for boundary wall (FRR). The boundary wall can be either timber or steel. The definition of a boundary wall is a wall which is 1.0m or less to a delineated boundary refer to NZBC C3.6, C3.7. NZBC Clause C3.3 states that “buildings must be designed and constructed so that there is a low probability of fire spread to other property vertically or horizontally across a relevant boundary”. NZBC clause 3.4 “Performance and NZBC B1.3.3.i,b and 2.2.4 (b) (iii) “a uniformly distributed horizontal face load of 0.5 kPa in any direction.” In other words to put it in simple terms the boundary wall needs fire ratings on both sides of the wall (two way system) the wall must stand so that it won't fall into a neighbouring property or boundary, fire service personnel will not be endangered by the wall collapsing for the required specified (FRR).

The architect or designer must ensure that the wall has enough structural stability for the required (FRR) in an event of a fire by taking into account the provisions of NZBC clause B1, it may be required that a structural engineer gives guidance.

All timber framing either on timber or concrete floor to the boundary wall to be as per the latest edition of NZS 3604. A boundary wall exterior will require a (FRR) cladding. Limitations of this manual are to NZS 3604 and NASH, for taller buildings (greater than two stores) a structural or fire engineer may need to evaluate the building.

Refer to this manual for exact fixings and layer combinations.

EFS-309

#### Bottom Plate Fixing

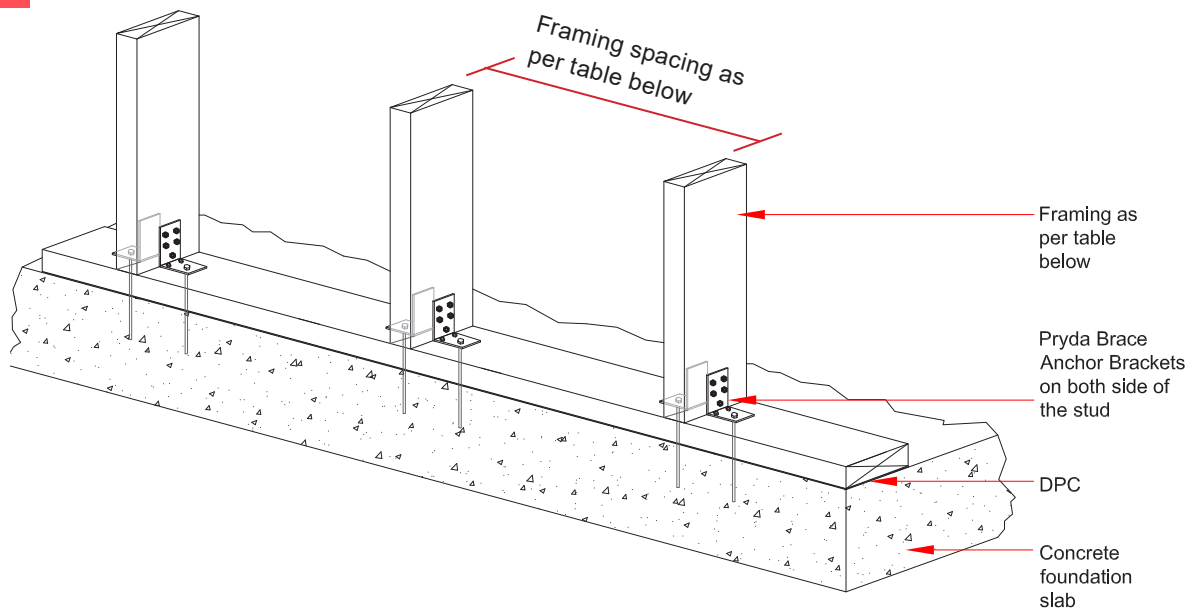

Note:

This detail is only indicative, confirmation will be required by a structural engineer for stability NZBC B1 by designer. Elephant plasterboard (NZ) Ltd accepts no liability if not verified by an engineer

Wall Height max (mm)	2400	3000	3700
Bottom Plate (mm)	90 x 45	140 x 45	140 x 45
Stud Spacing max (mm)	400	600	400
Nog Spacing (mm)	800	800	800
Hold Down brackets	Pryda Brace Anchor to both sides of Stud		



Boundary Wall Detail

EFS-310

Boundary Wall Cross Section

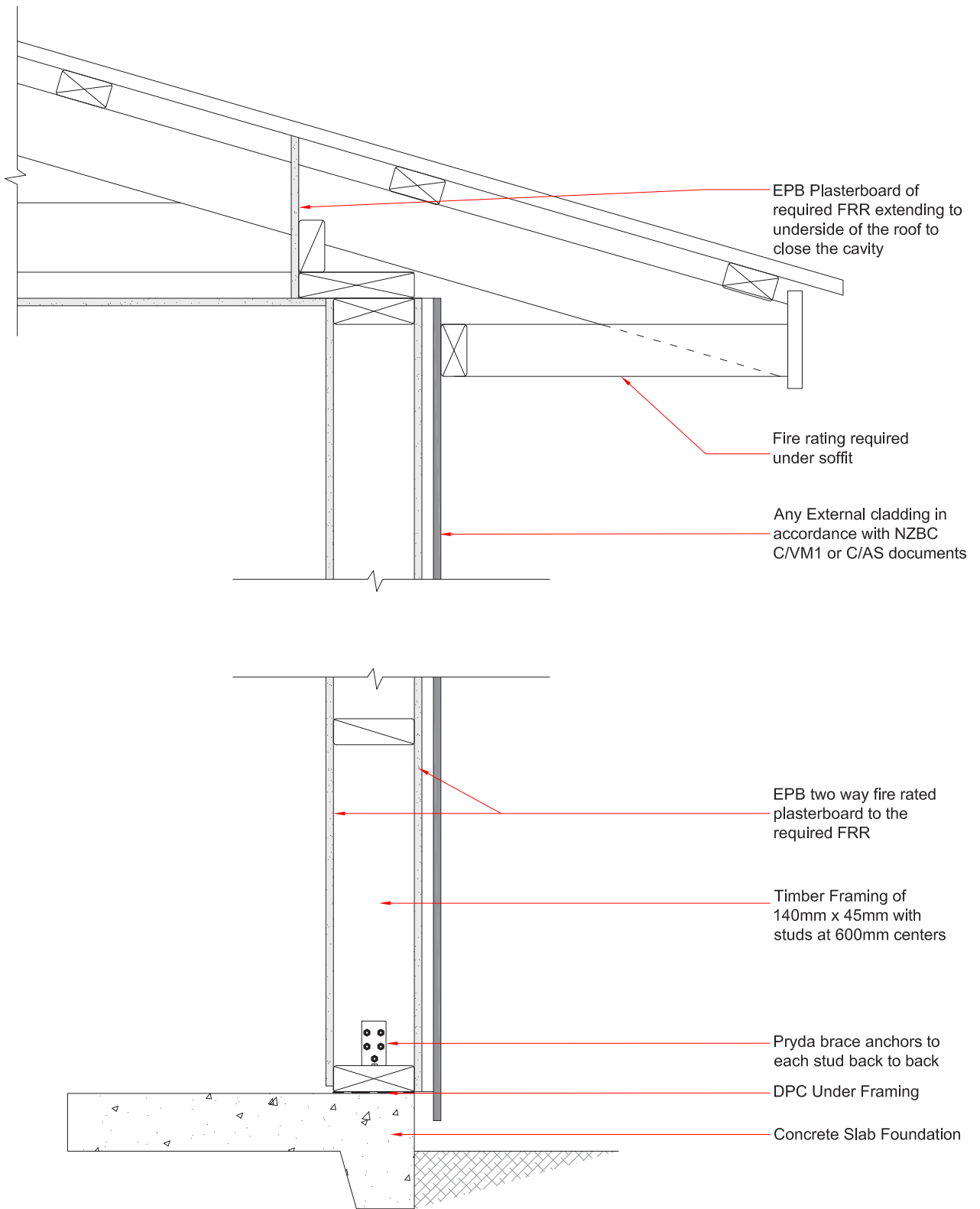

Wall Height max (mm)	2400	3000	3700
Bottom Plate (mm)	90 x 45	140 x 45	140 x 45
Stud Spacing max (mm)	400	600	400
Nog Spacing (mm)	800	800	800
Hold Down brackets	Pryda Brace Anchor to both sides of Stud		

**Note:** Ground clearances as per E2/AS1 and the product technical specification/installation manual



# EPB Plasterboard Product Range

## Product Weights and available Lengths

EPB PLASTERBOARD PRODUCT RANGE	EDGE TYPE	WIDTH	AVG WEIGHT	LENGTH								
				mm	Kg/m <sup>2</sup>	2.4m	2.7m	3.0m	3.3m	3.6m	4.2m	4.8m
10mm EPB® Standard	TE/TE	1200	6.9	✓	✓	✓	✓	✓	✓	✓	✓	✓
10mm EPB® Standard	TE/SE	1200	6.9	✓		✓		✓	✓	✓	✓	✓
10mm EPB® Standard - Wide	TE/SE	1350	6.9					✓		✓	✓	✓
13mm EPB® Standard	TE/TE	1200	8.8	✓	✓	✓	✓	✓	✓	✓	✓	✓
10mm EPB CeilingSmart®	TE/TE	1200	7.4	✓	✓	✓	✓	✓	✓	✓	✓	✓
10mm EPB FireSmart®	TE/TE	1200	7.4	✓	✓	✓	✓	✓	✓	✓	✓	✓
13mm EPB FireSmart®	TE/TE	1200	11.7	✓	✓	✓	✓	✓				
16mm EPB FireSmart®	TE/TE	1200	14.7	✓	✓	✓						
10mm EPB MultiSmart®	TE/TE	1200	8.9	✓	✓	✓		✓			✓	
10mm EPB MultiSmart®	TE/SE	1200	8.9								✓	
10mm EPB MultiSmart® - Wide	TE/SE	1350	8.9								✓	
13mm EPB MultiSmart®	TE/TE	1200	12.2	✓	✓	✓	✓	✓				
10mm EPB AquaSmart®	TE/TE	1200	8.3	✓	✓	✓		✓				
10mm EPB AquaSmart®	TE/SE	1200	8.3	✓							✓	
13mm EPB AquaSmart®	TE/TE	1200	11.7	✓	✓	✓		✓				

TE/TE = Tapered Both Edges    TE/SE = Tapered One Edge, Square the Other

## Product Primary Functions\*

EPB PLASTERBOARD PRODUCT RANGE	EDGE TYPE	WIDTH	Horizontal Fixing	Span 600 Centres on Ceilings	Bracing	Fire Resistance	Noise Control	Impact Resistant	Moisture Resistant
10mm EPB® Standard	TE/TE	1200			✓	✓			
10mm EPB® Standard	TE/SE	1200	✓		✓				
10mm EPB® Standard -Wide	TE/SE	1350	✓		✓				
13mm EPB® Standard	TE/TE	1200		✓		✓			
10mm EPB CeilingSmart®	TE/TE	1200		✓	✓	✓			
10mm EPB FireSmart®	TE/TE	1200		✓	✓	✓			
13mm EPB FireSmart®	TE/TE	1200		✓		✓			
16mm EPB FireSmart®	TE/TE	1200				✓	✓	✓	
10mm EPB MultiSmart®	TE/TE	1200		✓	✓	✓	✓		
10mm EPB MultiSmart®	TE/SE	1200	✓		✓		✓		
10mm EPB MultiSmart® - Wide	TE/SE	1350	✓		✓		✓		
13mm EPB MultiSmart®	TE/TE	1200		✓	✓	✓	✓	✓	
10mm EPB AquaSmart®	TE/TE	1200				✓	✓		✓
10mm EPB AquaSmart®	TE/SE	1200	✓						✓
13mm EPB AquaSmart®	TE/TE	1200		✓		✓	✓		✓

\* The above table details the product's Primary functions.  
Some products may perform more than the functions indicated



# EPB Plasterboard Product Range

**10mm EPB Standard**

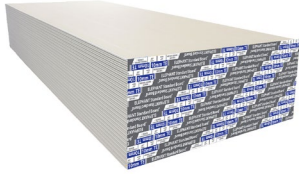

**10mm EPB Horizontal Standard**



**13mm EPB Standard**



**10mm EPB FireSmart/CeilingSmart**



**13mm EPB FireSmart**



**16mm EPB FireSmart**



**10mm EPB MultiSmart**



**10mm EPB Horizontal MultiSmart**



**13mm EPB MultiSmart**



**10mm EPB AquaSmart**



**10mm EPB Horizontal AquaSmart**



**13mm EPB AquaSmart**





FOR MORE INFORMATION

EMAIL [info@epb.co.nz](mailto:info@epb.co.nz)

CALL 0800 353 742